

Mini-G series

Embedded Amplifier Photo Sensors



- Ultra small size ideal for embedded use
- IP 67 water resistance for wet environments
- Stability output is provided
- High-speed response of 0.35 ms
 - High-powered light penetrating business cards: GT1SN, GT1N
 - Long detecting distance of 10 m: GT3RSN
 - High-performance detection at shorter distance: GS5SN, GS5N
 - Less affected by background: limited reflection type
 - Easy light axis alignment: red LED type

Type

Detection method	Detecting distance	Model		Operation mode	Output mode
		Side-on type	Head-on type		
⬆ Through-beam type	1m	GT1SN	_____	Light-ON/ Dark-ON selectable (with switch)	NPN Open collector
	7m	_____	GT1N		
	10m	_____	GT3N		
	7m	GT3RSN	_____		
⬆ Reflector type	0.01~2m	GSM2RSN	_____		
		GS5SN	_____		
⬆↕ Diffuse-reflective type	70mm	_____	GS5N		
	400mm	GS20RSN	_____		
	300mm	_____	GS20RN		
	300mm	GS20SN	_____		
⬆ Limited reflection type	200mm	_____	GS20N		
	1~40mm	GSZ3SN	_____		
	3~30mm	GSZ3RSN			

Optional Parts

Type	Model	Pinhole diameter	Applicable model and detecting distance (attached to both transmitter and receiver)	
Pinhole plate (SUS)	GP1	φ 1mm	GT3RSN400mm GT7SN300mm	Two plates required for attaching to both transmitter and receiver.
	GP2	φ 2mm	GT3RSN1m GT7SN1m	
	GP3	φ 3mm	GT3RSN3m GT7SN2.5m	
	GP5-1	5 x 1mm	GT3RSN2m GT7SN1.7m	

(Models GT1N is provided with stick-on pinhole sheets.)

• Attachment of pinhole plate

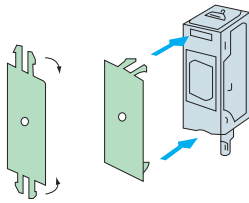

Manually bend the top and bottom parts at the base and insert the bent parts into the sensor slits.

Protective cover	G-MSB1	Applicable to side-on type	Rigid SUS covers for protecting sensors and reflectors from impact, etc. See p. 211 for details.
	G-MTB1		
	G-K7B	Applicable to K-7 and K-71 reflectors	

• Applicable power supply unit

PS series
High capacity of 200 mA at 12 VDC

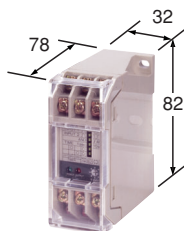

(General-purpose type) PS3N
PS3N-SR
(Multifunctional type) PS3F
PS3F-SR

Mini-G

Rating/Performance/Specification

Type	Side-on	GT1SN	—	GT3RSN	GT7SN	GSM2RSN	GS5SN	GS20RSN	GS20SN	GSZ3SN	GSZ3RSN
	Head-on	GT1N	GT3N	—	—	—	GS5N	GS20RN	GS20N	—	—
Detection method	Through-beam type					Reflective type	Diffuse-reflective type			Limited reflection type	
Detecting distance	1m	7m	10m	7m	0.01~2m*	70mm	400mm (GS20RSN) 300mm (GS20RN)	300mm (GS20SN) 200mm (GS20N)	1~40mm	3~30mm	
Detection object	φ 6mm (Min.) Opaque					—	50 x 50 mm white drawing paper	100 x 100 mm white drawing paper		—	
Power supply	24V DC ±10% / Ripple 10% max.										
Current consumption	Transmitter: 23mA max. Receiver: 18 mA max.		Transmitter: 20mA max. Receiver: 18 mA max.		Transmitter: 23mA max. Receiver: 18 mA max.		20mA max.	25mA max.	20mA max.	22mA max.	20mA max.
Output mode	Control output	NPN open collector output Rating: sink current 100 mA (30 VDC) max. (PNP output type also available)									
	Stability output	NPN open collector output Rating: sink current 50 mA (30 VDC) max. (PNP output type does not have stability output)									
Operation mode	Light-ON/Dark-ON selectable (with switch)										
Response time	0.35ms max.										
Hysteresis	—						10% max.				
Operating angle	30° (at receiver)	10° (at receiver)				30° (at reflector)	—				
Light source (light wavelength)	Infrared LED (880nm)		Red LED (700nm)	Infrared LED (880nm)	Red LED (700nm)	Red LED (900nm)	Red LED (700nm)	Red LED (900nm)	Red LED (900nm)	Red LED (900nm)	Red LED (700nm)
Indicator	Transmitter: Power indicator (red LED) Receiver: Operation indicator (red LED) Stability indicator (green LED)					Operation indicator (red LED) Stability indicator (green LED)					
Volume	SENS: Sensitivity adjustment (on receiver for through-beam type)										
Switch	Light-ON/Dark-ON selector switch provided L.ON side---Light-ON / D.ON side--- Dark-ON On the bottom for head-on type, on the back for side-on type										
Short circuit protection	Provided (for control output only)										
Material	Case	Polyarylate									
	Lens	Polycarbonate	Polyarylate			Polycarbonate	Polyarylate		Polycarbonate	Acrylic	
Connection	Permanently attached cord (outer dimension: dia. 3) (Transmitter) 0.15 sq. 2 core 2 m length (gray) (Receiver) 0.15 sq. 4 core 2 m length(black)					Permanently attached cord (outer dimension: dia. 3) 0.15 sq. 4 core 2 m length(black)					
Mass	About 50 g (transmitter/receiver)					Approx. 50g					
Notes	(Pair of) pinhole sheets provided (only GT1N)	—			Pinhole plates optional		*When used with K-71 reflector provided				
	Mounting bracket, operation manual provided										

Environmental Specification

Environment	Ambient light	5,000 lx max.
	Ambient temperature	-25 - +55 -C (non-freezing)
	Ambient humidity	35~85%RH (non-condensing)
	Protective structure	IP67
	Vibration	10~55 Hz / 1.5 mm amplitude / 2 hours each in 3 direction
	Shock	500 m/s2 / 3 times each in 3 directions
	Dielectric strength	1,000 VAC for 1 minute
Insulation resistance	500 VDC, 20 MΩ or higher	

* Detecting distances for different reflectors

The detecting distance depends on the reflector used.

Reflector model	K-71	K-7	S-25
Detecting distance	0.01 - 2m	0.01 - 3m	70 - 400mm

Input/Output Circuit and Connection

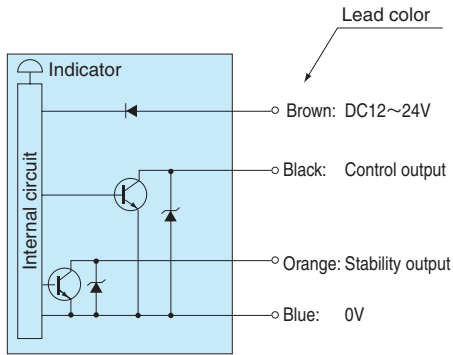

- The transmitter is provided with power supply lines (brown: 12 - 24 VDC; blue: 0 V) only.
- The output transistor turns off when load short circuit or overload occurs. Check the load and turn the power back on.

Characteristics (Typical Example)

• Directional characteristics

GT1SN·GT1N

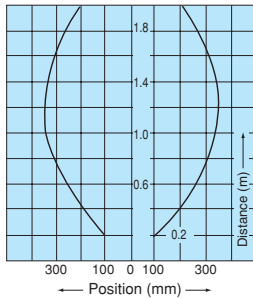

GT3N·GT7SN

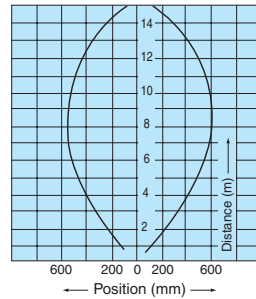

GT3RSN

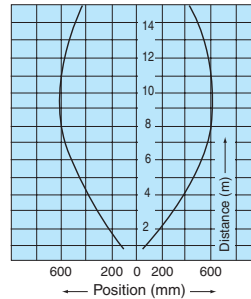

GSM2RSN (K-71)

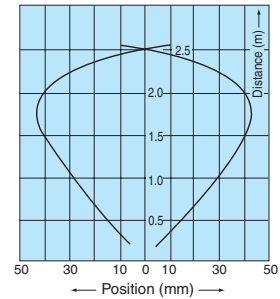

• Operating angle characteristics

GT1SN·GT1N

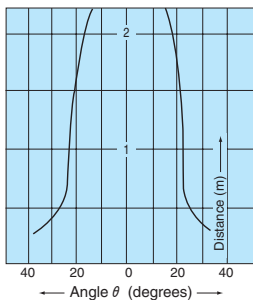

GT3N·GT7SN

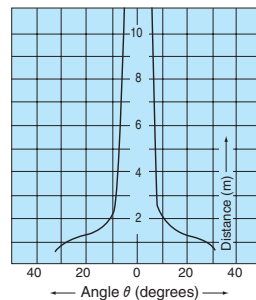

GT3RSN

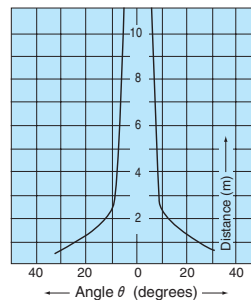

GSM2RSN (K-71)

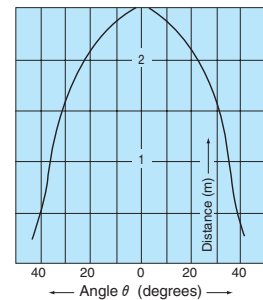

• Temperature characteristics

Reflective type

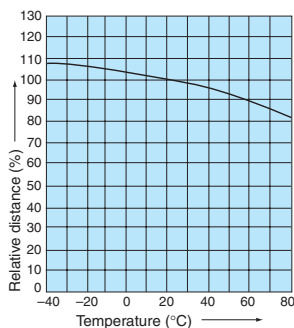

Through-beam type

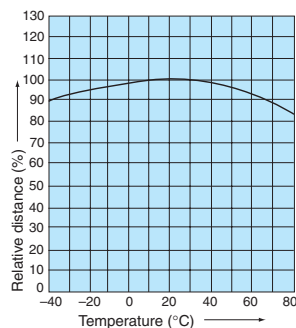

Mini-G

• Activation area characteristics

GS5SN

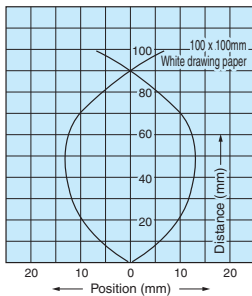

GS5N

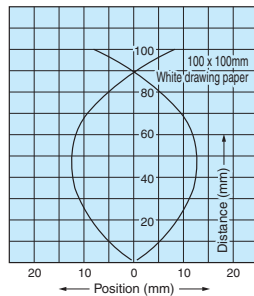

GS20RSN

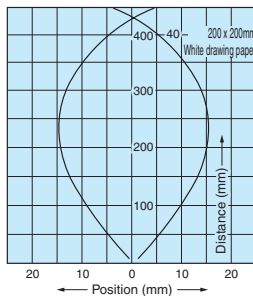

GS20RN

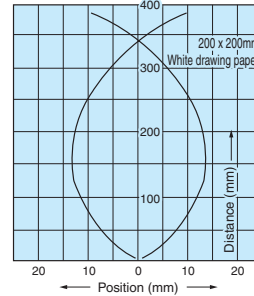

GS20N

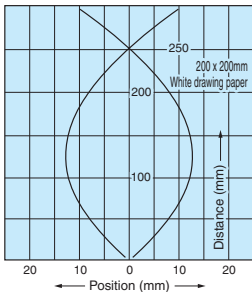

GS20SN

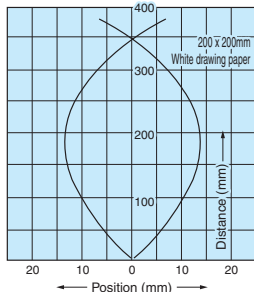

GSZ3SN

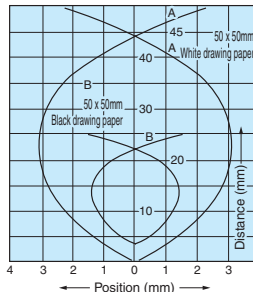

GSZ3RSN

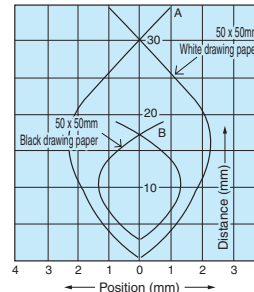

• Distance-area characteristics

GS5SN

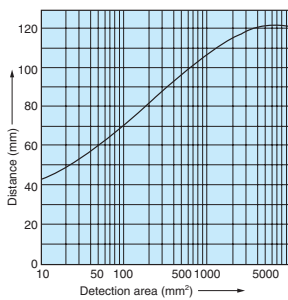

GS5N

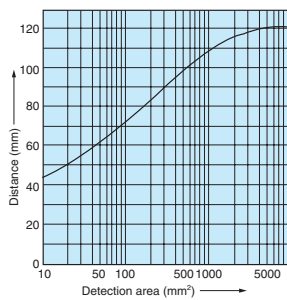

GS20RN

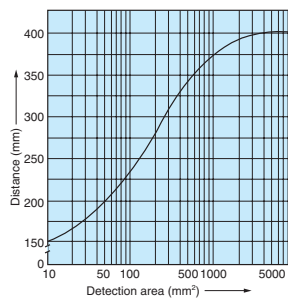

GS20RSN

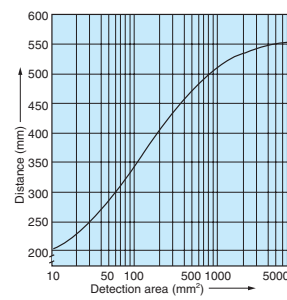

GS20N

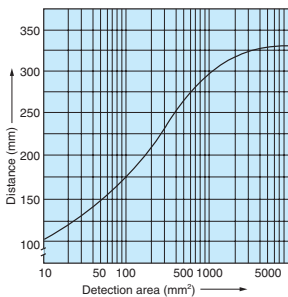

GS20SN

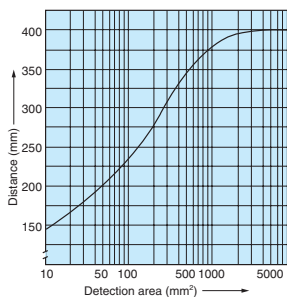

Dimensions (in mm; tightening torque for mounting screws: 0.6 N·m max.)

Side-on type

CAD

- GT1SN
- GT3RSN
- GT7SN
- GS5SN
- GSM2RSN
- GS20RSN
- GS20SN
- GSZ3SN
- GSZ3RSN

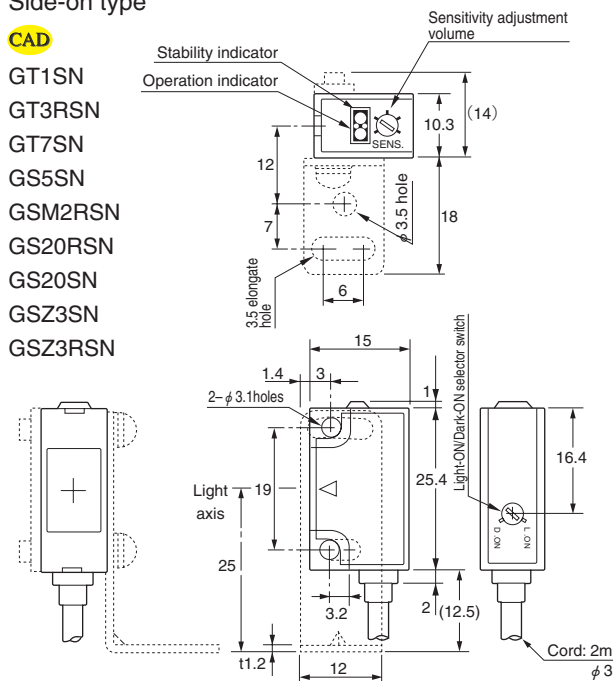

*The transmitter side of the through-beam type is provided with power indication only.

Head-on type

CAD

- GT1N
- GT3N
- GS5N
- GS20N
- GS20RN

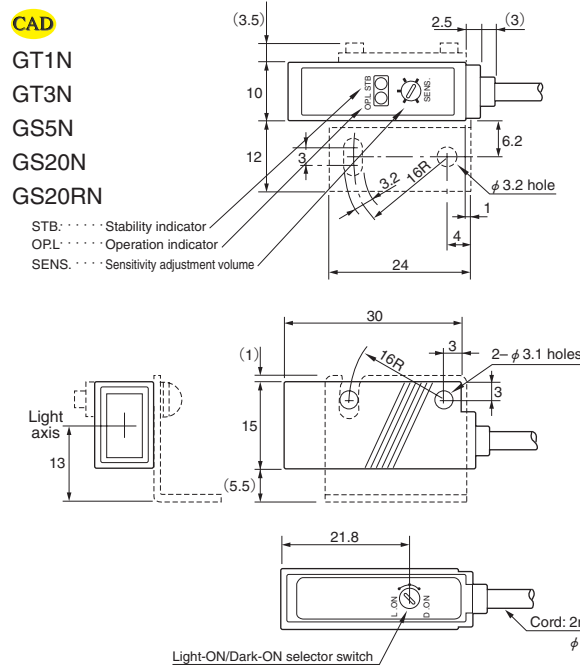

*The transmitter side of the through-beam type is provided with power indication only.

Reflector

CAD

K71

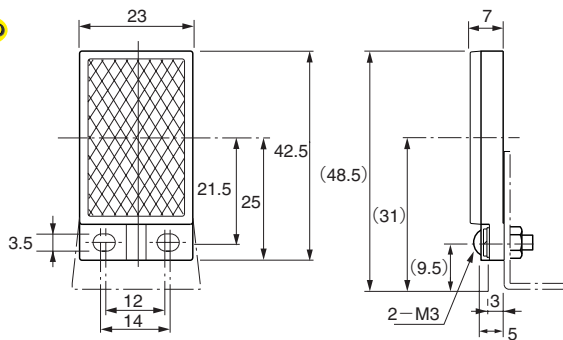

(Applicable to polarization reflector type
Effective reflecting surface: 19 x 32 mm
Mounting: mounting bracket provided, secured with M3 screws (alternatively adhesive may be used)

Indicators

- The operation indicator (red LED) and stability indicator (green LED) show the levels of light intensity as described in the figure below.
- After aligning the optical axis and adjusting the sensitivity, use a detection object to block and unblock the light beam several times to make sure that the sensitivity level is in a range that allows stable activation and deactivation.
- Setting the sensitivity in a range allowing stable operation achieves higher reliability against changes in the operating environment generated after the sensitivity is set.

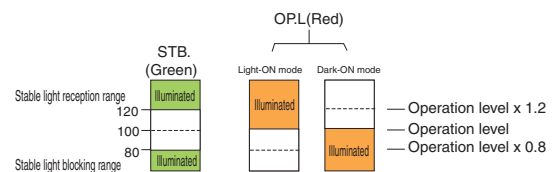

The orange LED (OPL) is the operation indicator.

In the L.ON (Light-ON) mode, the indicator is illuminated when a certain amount of light is detected.

In the D.ON (Dark-ON) mode, the indicator is illuminated when a certain amount of light is not detected.

Stability output

The stability output can be used to check for reduction of the light intensity level along with any change in the operating environment or operation over time or to perform initial check of the operation. When two consecutive detections have occurred with the intensity of light detected exceeding the operation level but not reaching 120% of the level (range allowing stable operation), the stability signal is output when the control output is deactivated. (This output is not available with the PNP output types of the Mini-G Series.)

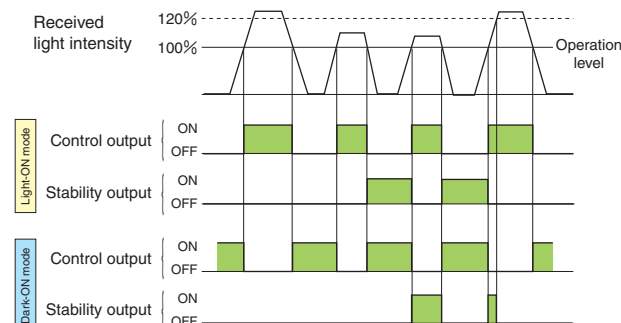

Sensitivity adjustment (for Light-ON mode)

(Adjustment for Light-ON mode)

- When any light-reflecting object is in the background
- (1) Place the object to be detected in a given position, turn up the sensitivity adjustment volume (SENS.) gradually and find the point at which the operation indicator (red LED) is illuminated (Point A).
- (2) Remove the object, turn down the sensitivity adjustment volume gradually from MAX. and find the point at which the operation indicator (red LED) goes out (Point B). (If the operation indicator is not illuminated even at Max., MAX. is regarded as Point B.)
- (3) Set the volume at midway between Points A and B.

