

CX series

DC POWER SUPPLY
PHOTO SENSORS

- M18 cylinder type that is accordance with the European standard(CENELEC)
- Polarised light reflector type that can detect mirrored objects.
- Complete short circuit protection
- Waterproof to IP66 because of resin encapsulation.
- Resistant to shock and vibration furthermore environmental performance has been dramatically improved, i.e. the unit is much more robust.

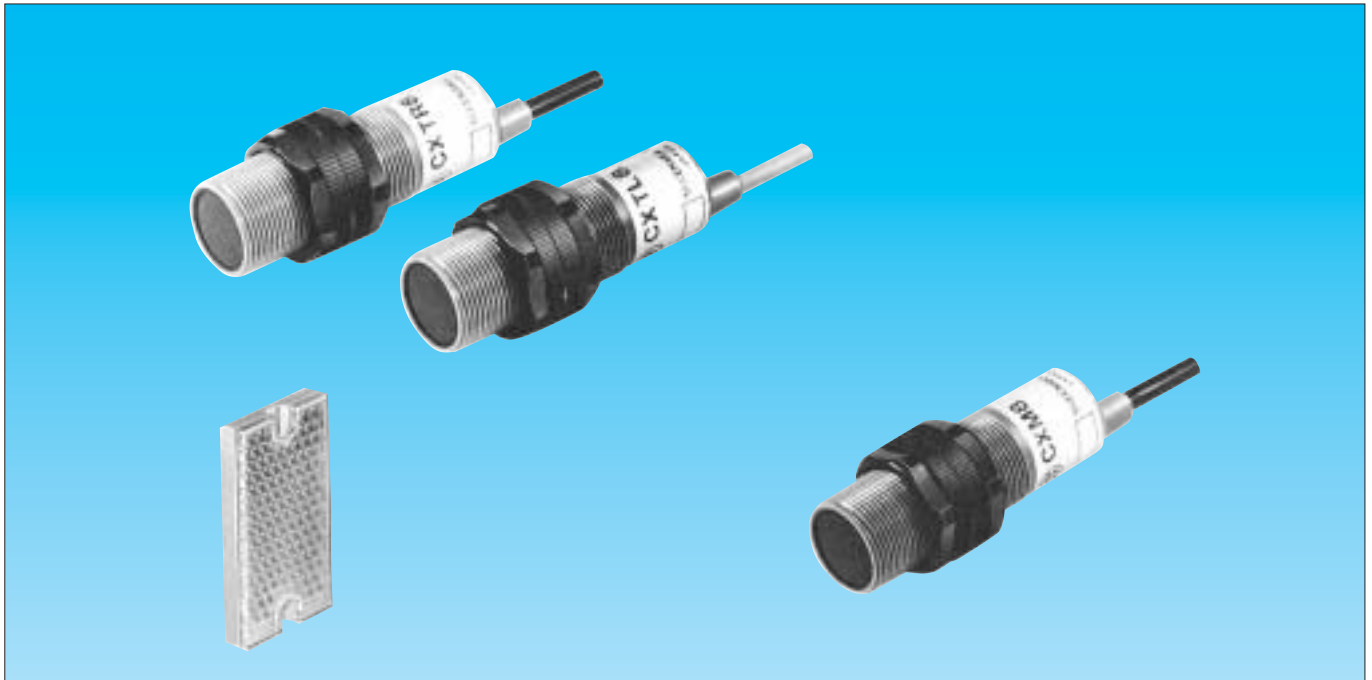

OUTPUT CIRCUIT

NPN OUTPUT

CX-M2RD
CX-R01
CX-R03V

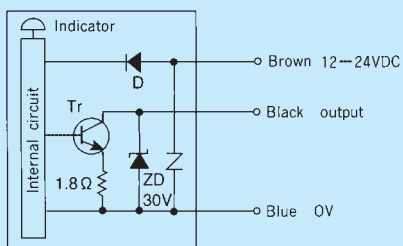

PNP OUTPUT

CX-M2RDPN
CX-R01PN
CX-R03PN

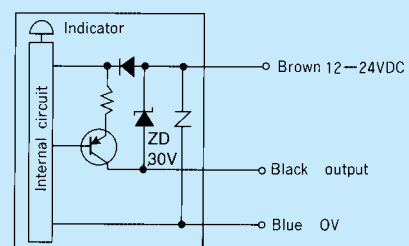

CXT8

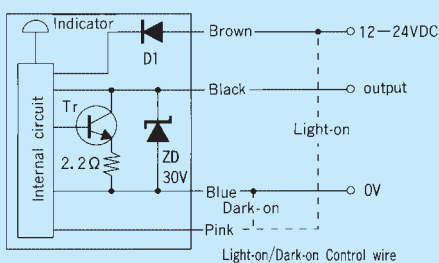

CXT8PN

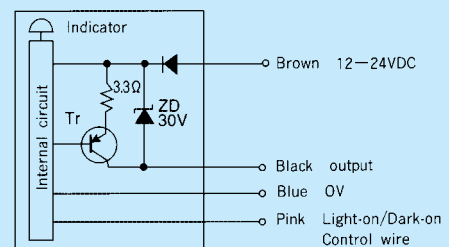

SPECIFICATIONS

Models	NPN Output	CXT8 1	CX-M2RD	CX-R01	CX-R03V
	PNP Output	CXT8PN 2	CX-M2RDPN	CX-R01PN	CX-R03VPN
Detection	Through beam		Polarized Retro reflection	Diffuse reflection	
Range	3m		2m 1	10cm 2	30cm 3
Detecting object	15mm(Max.)Opaque		Opaque	-	
Power supply	12 - 24VDC \pm 10%, Ripple 10%(Max.)				
Current consumption (Max)	NPN	Tr. : 25mA Rcvr. : 15mA	18mA	17mA	20mA
	PNP	15mA	24mA	23mA	26mA
Output mode	NPN	NPN open collector Rating : Sink current : 100mA, DC30V(Max.)			
	PNP	PNP open collector Rating : Source current : 100mA, DC30V(Max.)			
Operating mode	Light-On, Dark-On		Dark-On	Light-On	
Response time	1msec(Max.)		0.35msec(Max.)		
Hysteresis(Max.)	-		-	5%(Max.)	
Beam deviation	7 (Rcvr)		10 (Reflector)	-	
Light source Wavelength	Infrared LED		Red LED	Infrared LED	
	940nm		700nm	950nm	
LED Indicator	Trns. : Power(Red) Rcvr. : Light(Red)		OPERATION(Red LED)		
Sensitivity adjustment	-				Built-in potentiometer
Circuit protection	Built in Short circuit protection				
Material	Case & Lense : Polycarbonate		Lenses : Acrylic Case : Polycarbonate	Case & Lense : Polycarbonate	
Connection	Cable(Outer 4mm \varnothing m Length Trns. : Gray 0.2 ϕ \times 2C Rcvr. : Black 0.2 ϕ \times 4C		Flying lead(0.2 ϕ \times 3C \varnothing m Length		
Weight(Max.)	Tr. : 65g, Rcvr. : 65g		65g		

- 1 K-7 Reflector
- 2 50 \times 50 White paper
- 3 100 \times 100 White paper

ENVIRONMENT

Ambient light	Withstands 5,000 lx(Max.)
Operating temp.	- 25 ~ + 55
Humidity	35 ~ 85%RH
Case protection	IP66
Vibration	10Hz ~ 55Hz, 1.5mm Amplitude 2Hr., 3 Directions
Dielectric withstanding	AC1,000V, 1 minute
Insulation resistance	DC500V, 20M (Min.)

ACTIVE BEAM WIDTH

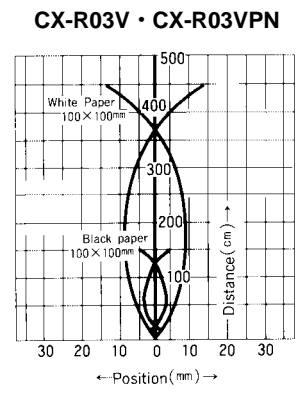
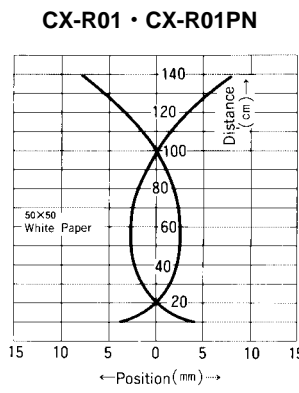
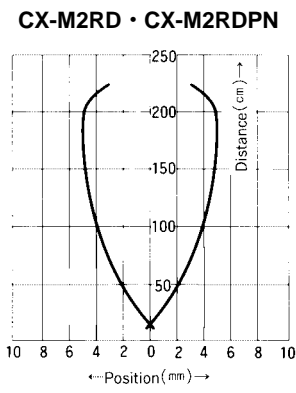
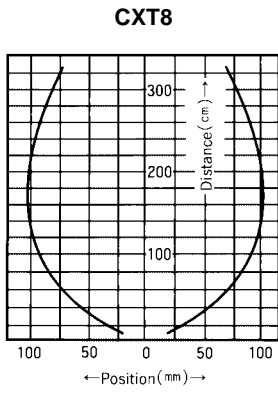

OPERATING ANGLE

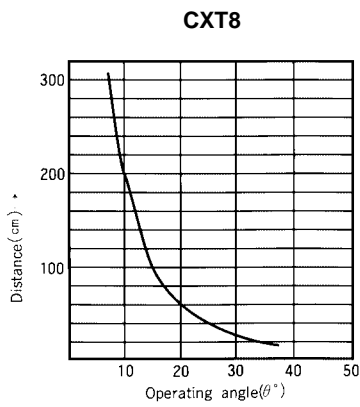

SENSING DISTANCE VS. OBJECT SIZE

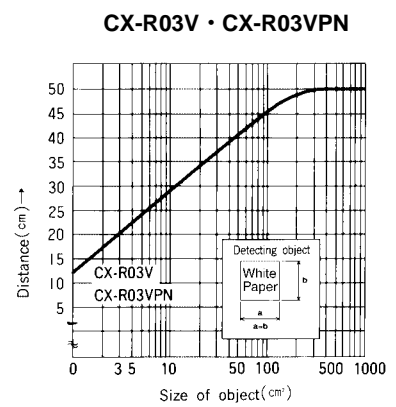
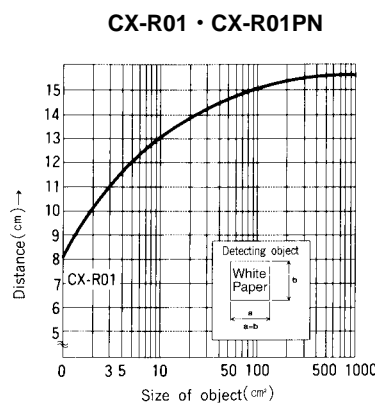

TEMPERATURE CHARACTERISTICS

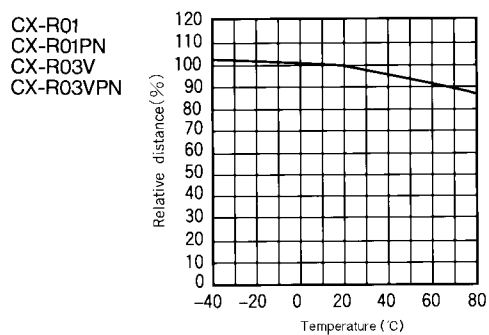
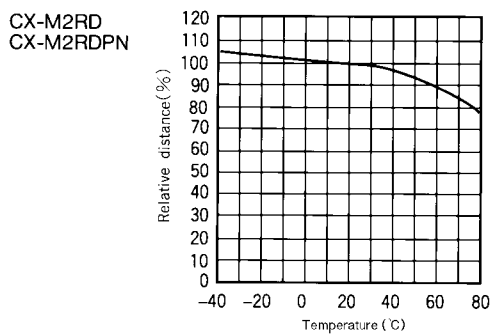

DIMENSIONS

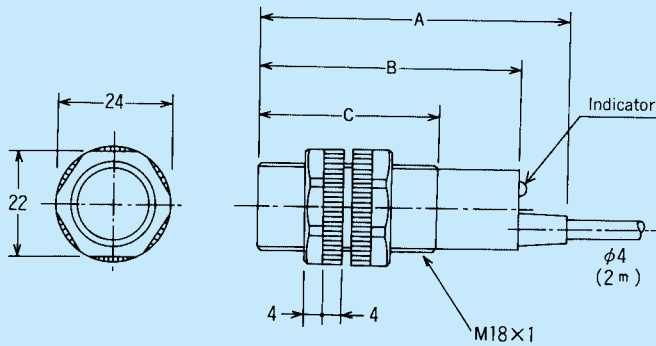

(mm)

Models	A	B	C
CX-M2RD	66.2	56.2	38.2
CX-M2RDPN			
CXT8			
CX-R01			
CX-R01PN	65	55	37
CX-03V			
CX-R03VPN			

K-7 Reflector

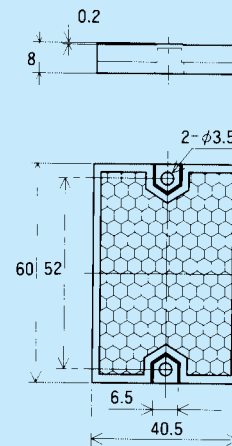

(Cautions during installation)

- If the nut on the unit body is tightened with excessive force, the thread of the screw can be damaged. Maximum tightening torque $0.98\text{N}\cdot\text{m}$ ($10\text{kg}\cdot\text{cm}$).
- This product cannot allow installation angle adjustment once it is fixed. Be careful not to let the optical axis change when setting, especially with the through-beam type.

HOW TO MOUNT SENSORS

(Through-beam type)

- Set the optical axis adjustment in the centre of the range where the light-IN indicator (red LED) lights, by moving the receiver up / down and left / right.
- Check the operation by interrupting and not interrupting the light.

(Polarised light reflector type)

- Set so that the sensor and the reflector line up. Then, position the reflector in the centre of the area where the unit shows a light-IN condition (the operation indicator goes off) by moving the reflector up / down and left / right. When the setting is correct, the reflector surface lights up red when viewed from behind the sensor, which makes the setting very easy.

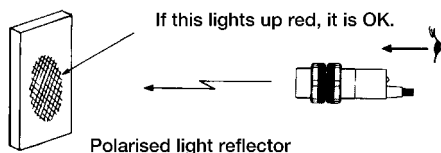

(Diffuse reflective type)

- Set the unit so that the operation indicator (red LED) lights up when the detection object is placed in the correct position, and the operation indicator goes off when the detection object is removed.
- Ensure the background of the detection area is as far away as possible or that it is a matt black surface that has a low reflection ratio.
- This sensor changes the detection distance using the surface condition of the detection object. This sensor does not have a sensitivity adjustment, therefore adjust for stable operation by changing the detection distance, angle or the background surface.

(Diffuse reflective type with adjustment)

- Adjustment when there is a reflective background.

Set the detection object in the correct position, raise the sensitivity adjustment (SENS) gradually from the minimum (MIN) and make the point where the operation indicator (red LED) lights point A.

Next, lower the sensitivity adjustment (SENS) gradually from the maximum (MAX) without any detection object, make the point where the operation indicator goes off point B. (If the operation indicator does not light up with the maximum sensitivity, the MAX point will become the point B)

Set the adjustment to the mid point between points A and B, and the adjustment is complete.

