

SRB7448

Shift register



- Compact
- 800-bit support
- Sensor power supply integrated

(12 VDC 150 mA max.)

More than one sensor may be directly connected

Type

Type	Model	Bit count	Operation mode	Output mode	Power supply
Head terminal type	SRB-7448	800bit	ON-OFF operation	Photo-MOS relay 1a	12-24V DC ±10% 50-60Hz

Panel Description

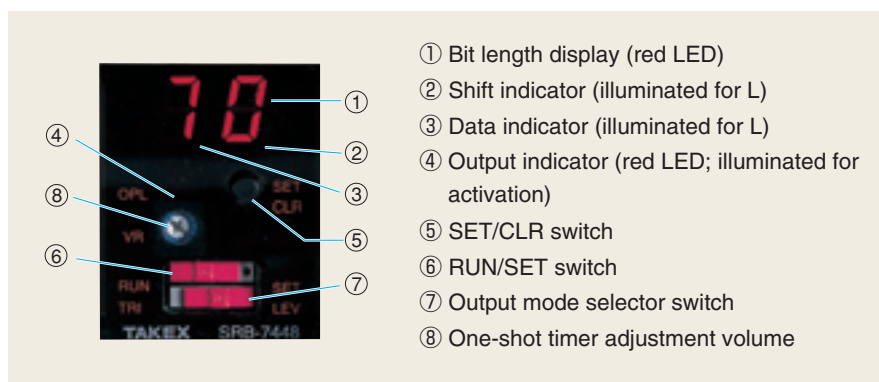

Rating/Performance/Specification

Rating/performance	Type	Head terminal type
	Model	SRB-7448 (-H) *
	Power supply	100-240VAC ±10% 50/60Hz
	Power consumption	10W max.
	Input signal (common to all inputs)	Open collector: L level: ON; H level: OFF Voltage: L level: 0-1 V; H level: 6-30 V
	Data input	LEV: activated at L level (minimum input pulse width: 25 ms) * TRI: activated at trigger level (minimum input pulse width: 25 ms) *
	Shift input	Shift at H -> L (fall) Minimum input pulse width: 25 ms
	Reset input	Reset at L level Minimum input pulse width: 25 ms
	Bit count	Variable between 1 and 800 bits
	Operation mode	LEV: ON-OFF operation (shift input synchronized) TRI: one-shot operation (variable between 0.1-3 seconds)
	Output mode	Photo-MOS relay 1a 220 VAC/DC 50 mA
Specification	Power supply to sensor	12VDC 150mA
	Connection	Terminal block (with M3.5 screws; terminal block width: 8.1 mm)
	Case material	ABS resin
	Mass	150g max.
	Notes	<ul style="list-style-type: none"> • **"-H"

Environmental Specification

Environment	Ambient temperature	-10 - +55 °C (non-freezing)
	Ambient humidity	35-85%RH (non-condensing)
	Protective structure	IP40
	Vibration	10-55 Hz / 1.5 mm amplitude / 1 hour each in 3 directions
	Dielectric withstanding	1500 VAC for 1 minute
	Insulation resistance	500 VDC, 20 MΩ or higher

SRB

Input/Output Circuit

a) Input circuit

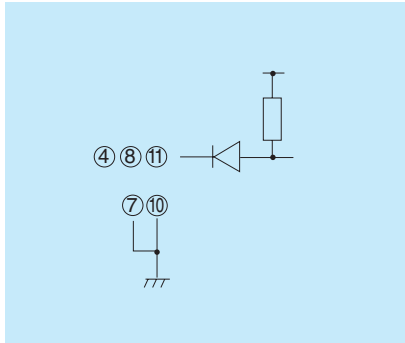

b) Output circuit

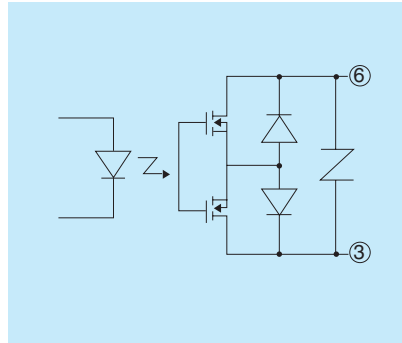
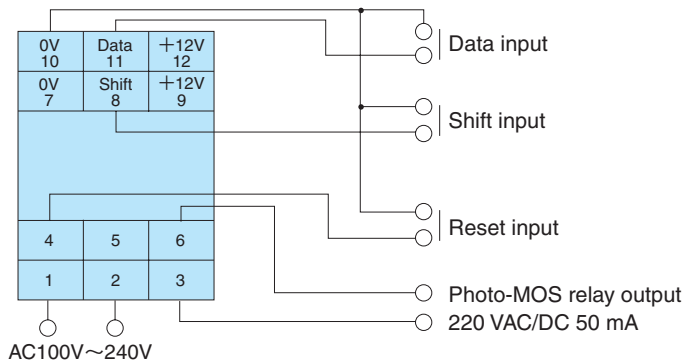

Photo-MOS relay output 1a
220 VAC/DC 50 mA

Output resistance at photo-MOS relay
activation (ON resistance): 50 Ω

Connection (Typical example)



Basic Operation

1) Input mode

- a. LEV (level input mode): data read at fall of shift input and shifted in order.
- b. TRI (trigger input mode): data input fall temporarily stored, read at fall of shift input and shifted in order.

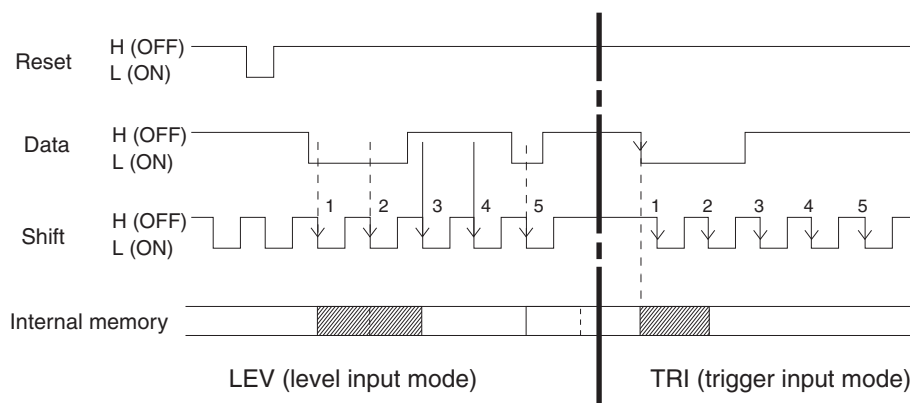

2) Operation mode

- a. LEV (level input mode): ON-OFF operation
Output is activated at the fall of a shift pulse and stays activated until the next fall. When continuous data signal is input, output stays activated.
- b. TRI (trigger input mode): one-shot operation
Output is activated at the fall of a shift pulse and stays activated for a certain period of time. The output time can be adjusted between 0.1 and 3 seconds with the volume on the panel. Use this mode when long output signals are required for a short shift cycle or short output signals for a long shift cycle.

Dimensions (in mm)

