

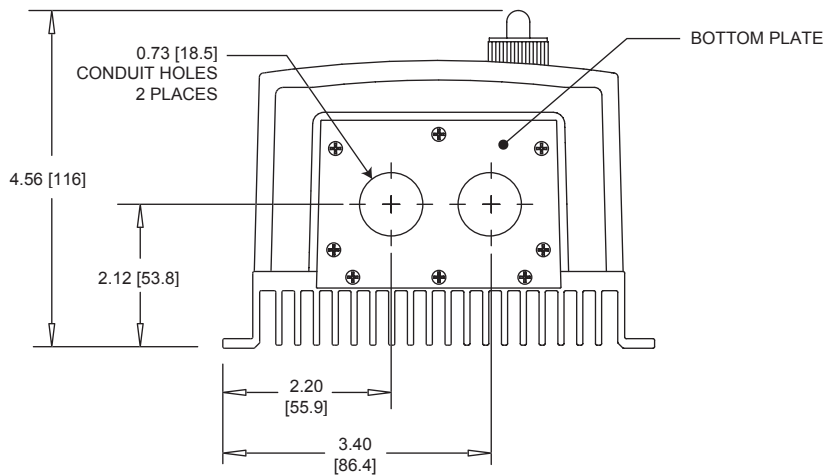

VFDP4X04-D230-PCM

Variable Frequency Drive for
3-phase & single phase AC motors

DIMENSIONS

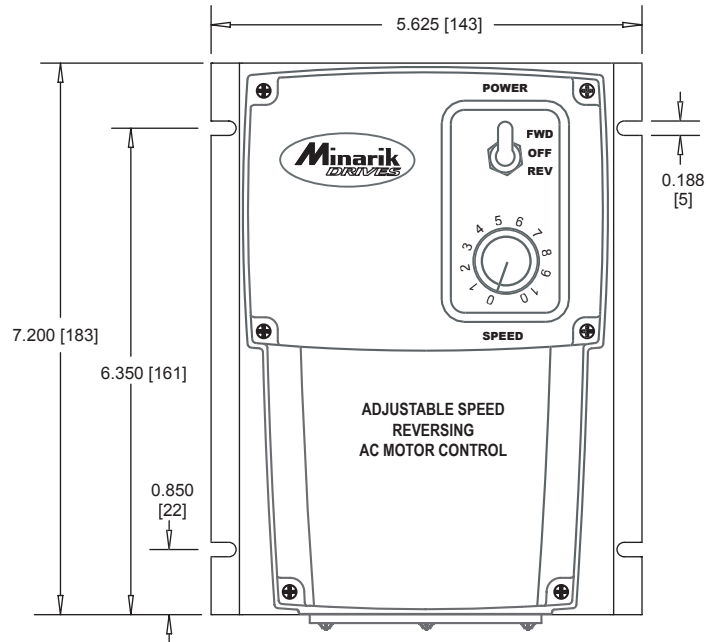

ALL DIMENSIONS IN INCHES [MILLIMETERS]

QUICK START GUIDE

SPECIFICATIONS

1-Phase Input* 115/230 VAC
1 or 3 -Phase Output 230 VAC
Maximum Horsepower1 HP
Maximum Continuous Output Current 4.0 AC
AC Amps In15 / 10 amps
AC Voltage Input Range115/230 VAC ± 10%, 50/60 Hz single phase
Standard Carrier Frequency16 KHz
Adjustable Braking Current 0 - 4 ADC
Adjustable Braking Time1 - 10 Sec.
Adjustable Minimum Speed0 - 30 Hz
Output Frequency Range0 - 120 Hz
Adjustable Maximum Output Frequency Range30 - 120 Hz
Acceleration Time Range1 - 12 secs
Deceleration Time Range1 - 12 secs
Analog Input Voltage Range (S1 [-] to S2 [+]) 0 - 5 VDC, 0 - 10 VDC, 4 - 20 mA
Input Impedance, S1 to S2 ~ 100K ohms
Vibration0.5G max (20 - 50 Hz) 0.1G max (> 50 Hz)
Weight1.2 lbs
Ambient Operating Temperature Range10° - 40° C

* Jumper settings MUST match input line voltage. Application of 230 VAC line input when jumpers are set for 115 VAC will result in severe damage to the drive.

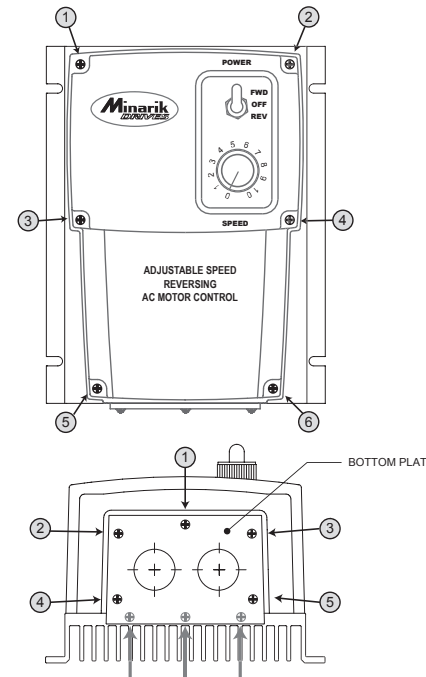

REMOVING THE CASE COVER

1. Remove the six (6) phillips screws on the front case.

NOTE: The two shorter screws (#6 - 32 x 2 1/2) on the front case are used at hole locations 5 & 6.

2. Remove the five (5) phillips screws on the bottom plate.

NOTE: DO NOT REMOVE the three (3) screws securing the bottom plate to the heatsink.

DO NOT REMOVE
THE THREE (3) SCREWS SECURING
THE BOTTOM PLATE TO THE HEATSINK

C O N N E C T I O N S

STEP #1-skip this step if provided FWD/OFF/REV and speed potentiometer will be used. Otherwise disconnect factory-wired connections from the FWD/OFF/REV switch and speed potentiometer. Connect the enable/disable switch, direction switch, and speed potentiometer or signal input to TB501 on the TOP board using 20 - 24 AWG wire as shown below.

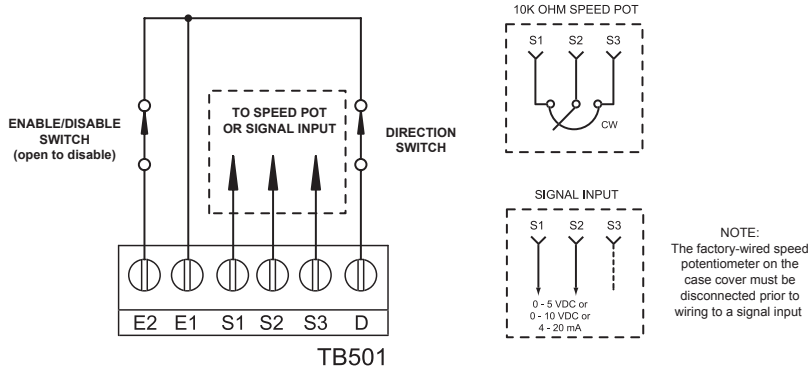

NOTE:
The factory-wired speed potentiometer on the case cover must be disconnected prior to wiring to a signal input

STEP #2
Configure jumpers JMP504 and JMP505 on the top board for the appropriate signal input.

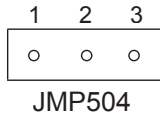

JMP504 (on top board)
Pins 1 & 2 for Voltage Input, or using a speed pot.
Pins 2 & 3 for Current Input

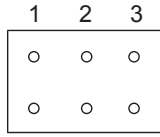

JMP505 (on top board)
Pins in Column 1 for 0 - 5 VDC Voltage Input, or using a speed pot
Pins in Column 2 for 0 - 10 VDC Voltage Input
Pins in Column 3 for 4 - 20 mA Current Input

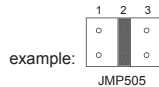

STEP #3
Configure jumpers JMP503 on the bottom board and JMP506 on the top board.

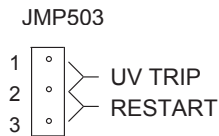

JMP503 (on bottom board)
Pins 1 & 2 to Trip
Pins 2 & 3 to Restart

TRIP: Drive has a low voltage fault & must be manually re-enabled to restart.
RESTART: Drive has a low voltage fault & will momentarily stop then auto-restart when input voltage returns to minimum level.

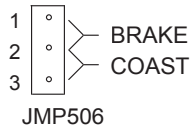

JMP506 (on top board)
Pins 1 & 2 to Brake
Pins 2 & 3 to Coast

STEP #4
Configure jumpers JMP501 and JMP502 on the bottom board for 115 or 230 VAC Power Input.

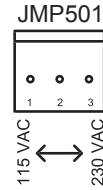

Pins 1 & 2 for 115 VAC
Pins 2 & 3 for 230 VAC

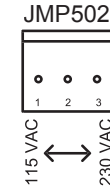

Pins 1 & 2 for 115 VAC
Pins 2 & 3 for 230 VAC

STEP #5
Connect motor leads of a 3-phase motor to U, V, and W (TB502 on BOTTOM board) using 14 - 16 AWG wire as shown in the figure below.

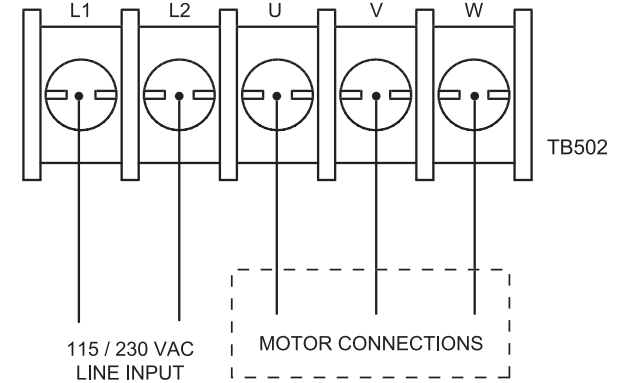

STEP #6
Connect 115 or 230 VAC power input using 12 AWG wire.

NOTE: Minarik strongly recommends installing an emergency stop switch on both the L1 and L2 inputs.

SINGLE-PHASE OPERATION
(motor with pre-wired capacitor)

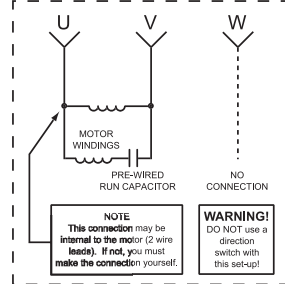

SINGLE-PHASE OPERATION
(for use with DIRECTION switch)

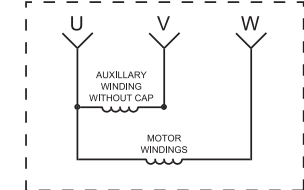

THREE-PHASE OPERATION

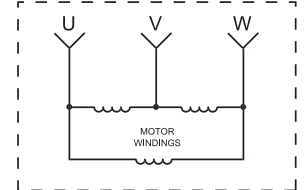

MINARIK DRIVES

www.minarikdrives.com

14300 De La Tour Drive, South Beloit, IL 61080; Phone: (800) MINARIK (646-2745); Fax: (815) 624-6960
Document Number: 250-0379, Revision 0; Printed in the U.S.A. - September 2003

Copyright 2003 by Minarik Corporation - All rights reserved. No part of this document may be reproduced or transmitted in any form without written permission from Minarik Corporation. The information and technical data in this document are subject to change without notice. Minarik Corporation and its Divisions make no warranty of any kind with respect to this material, including, but not limited to, the implied warranties of its merchantability and fitness for a given purpose. Minarik Corporation and its Divisions assume no responsibility for any errors that may appear in this document and make no commitment to update or to keep current the information in this document. mvd092503