



***WASHGUARD***<sup>®</sup>



**174102 & 174107**  
NEMA 4X SCR MOTOR CONTROLS

# Operation Manual

## LIMITED WARRANTY

A. Warranty - LEESON Electric warrants that its products will be free from defects in material and workmanship for a period of one (1) year from the date of shipment thereof. Within the warranty period, LEESON will repair or replace such products that are returned to LEESON or to the nearest Branch Office, with shipping charges prepaid. At our option, all return shipments are F.O.B. LEESON or its Branch Office. This warranty shall not apply to any product that has been subject to misuse, negligence, or accident; or misapplied; or repaired by unauthorized persons; or improperly installed. LEESON is not responsible for removal, installation, or any other incidental expenses incurred in shipping the product to or from the repair point.

B. Disclaimer - The provisions of Paragraph A are LEESON's sole obligation and exclude all other warranties of MERCHANTABILITY or use, express or implied. LEESON further disclaims any responsibility whatsoever to the customer or any other persons for injury to person or damage or loss of property of value caused by any product that has been subject to misuse, negligence, or accident, or misapplied or modified by unauthorized persons or improperly installed.

C. Limitations of Liability - In the event of any claim or breach of any of LEESON's obligations, whether expressed or implied, and particularly of any claim of a breach of warranty claimed in Paragraph A, or of any other warranties, express, or implied, or claim of liability that might, despite Paragraph B, be decided against us by any lawful authority, LEESON shall under no circumstances be liable for any consequential damages, losses, or expense arising in connection with the use of, or inability to use, LEESON's product for any purpose whatsoever. An adjustment made to the warranty does not void the warranty, nor does it imply an extension of the original one (1) year warranty period. Product serviced and/or parts replaced by a no-charge basis during the warranty period carry the unexpired portion of the original warranty only.

If for any reason any of the forgoing provisions shall be ineffective, LEESON's liability for damages arising out of its manufacture or sale of equipment, or use thereof, whether such liability is based on warranty, contract, negligence, strict liability in tort, or otherwise, shall not in any event exceed the full purchase of such equipment.

Any action against LEESON based upon any liability or obligation arising hereunder or under any law applicable to the sale of equipment or the use thereof must be commenced within one year after the cause of such action arises.

# Safety Warnings



- This symbol  denotes an important safety tip or warning. Please read these instructions carefully before performing any of the procedures contained in this manual.
- **DO NOT INSTALL, REMOVE, OR REWIRE THIS EQUIPMENT WITH POWER APPLIED.** Have a qualified electrical technician install, adjust and service this equipment. Follow the National Electrical Code and all other applicable electrical and safety codes, including the provisions of the Occupational Safety and Health Act (OSHA), when installing equipment.
- Reduce the chance of an electrical fire, shock, or explosion by proper grounding, over-current protection, thermal protection, and enclosure. Follow sound maintenance procedures.



## Warning

**It is possible for a drive to run at full speed as a result of a component failure.** LEESON strongly recommends the installation of a master switch in the main power input to stop the drive in an emergency.

Circuit potentials are at 115 VAC or 230 VAC above earth ground. Avoid direct contact with the printed circuit board or with circuit elements to prevent the risk of serious injury or fatality. Use a non-metallic screwdriver for adjusting the calibration trimpots. Use insulated tools if working on this drive with power applied.

# Contents

<b>Safety Warnings</b>	<b>i</b>
<b>Specifications</b>	<b>1</b>
<b>Dimensions</b>	<b>2</b>
<b>Overview</b>	<b>3</b>
<b>Installation</b>	<b>4</b>
Mounting	.4
Removing the Plastic Cover	.4
Line fusing	.4
Connections	.5
Field Output	.8
Voltage Switches	.8
<b>Calibration</b>	<b>10</b>
Calibration procedure	12
MINIMUM SPEED (MIN SPD)	12
MAXIMUM SPEED (MAX SPD)	13
REGULATION (IR COMP)	13
TORQUE LIMIT (TORQUE)	14
ACCELERATION (ACCEL)	15
DECELERATION (DECEL)	15
Calibration procedure conclusion	15
<b>Operation</b>	<b>17</b>
Before applying power	17
Startup	18
174102	18
174107	19

<b>Application Notes</b>	<b>20</b>
Inhibit circuit	20
Decelerating to minimum speed	22
Dynamic Braking	23
Multiple Fixed Speeds	25
Adjustable speeds using potentiometers in series	26
Independent adjustable speeds	27
RUN/JOG switch	28
RUN/JOG option #1	28
RUN/JOG option #2	29
Leader-follower application	30
Single speed potentiometer control of multiple drives	31
Reversing	32
<b>Troubleshooting</b>	<b>33</b>
Before troubleshooting	33
Power and Current Limit LEDs	34
Replacement Parts	38

# Illustrations

Figure 1. 174102 & 174107 Dimensional Diagrams . . . . .	2
Figure 2. Cover removal for terminal strip access . . . . .	6
Figure 3. Drive connections . . . . .	7
Figure 4. Voltage Switches . . . . .	9
Figure 5. Calibration Trimpot Layout . . . . .	11
Figure 6. Recommended TORQUE and IR COMP Settings for 174102 & 174107 Controls . . . . .	16
Figure 7. Inhibit Plug with Run/Coast to Minimum Speed . . . . .	21
Figure 8. Run/Decelerate to Minimum Speed Switch . . . . .	22
Figure 9. Dynamic Brake Connection . . . . .	24
Figure 10. Multiple Fixed Speeds . . . . .	25
Figure 11. Adjustable Fixed Speeds Using Potentiometers in Series . . . . .	26
Figure 12. Independent Adjustable Speeds . . . . .	27
Figure 13. RUN/JOG Switch Option #1 . . . . .	28
Figure 14. RUN/JOG Switch Connection to Speed Adjust Potentiometer . . . . .	29
Figure 15. Leader-Follower Application . . . . .	30
Figure 16. Single Speed Potentiometer Control of Multiple Drives . . . . .	31
Figure 17. Reversing Circuit Connection . . . . .	32
Figure 18. Current Limit LED . . . . .	34

# Tables

Table 1. Recommended Line Fuse Sizes . . . . .	5
Table 2. Field Output Connections . . . . .	8
Table 3. Replacement Parts . . . . .	38

# Specifications

<b>Model</b>	<b>Max. Armature Current (Amps DC)</b>	<b>HP Range with 115 VAC Applied</b>	<b>HP Range with 230 VAC Applied</b>	<b>Style</b>
174102	10.0	1/8–1	1/4–2	NEMA 4X
174107	10.0	1/8–1	1/4–2	NEMA 4X
<b>AC Line Voltage</b>		115 VAC or 230 VAC $\pm$ 10%, 50/60 Hz, single phase		
<b>Armature Voltage (115 VAC Input)</b>			0–90 VDC	
<b>Armature Voltage (230 VAC Input)</b>			0–180 VDC	
<b>Form Factor</b>			1.37 at base speed	
<b>Field Voltage (115 VAC Input)</b>		50 VDC (F1 to L1); 100 VDC (F1 to F2)		
<b>Field Voltage (230 VAC Input)</b>		100 VDC (F1 to L1); 200 VDC (F1 to F2)		
<b>Max. Field Current</b>			1 ADC	
<b>Accel. Time Range:</b>				
for 0–90 VDC Armature Voltage			1 – 11 seconds	
for 0–180 VDC Armature Voltage			1 – 25 seconds	
<b>Analog Input Voltage Range (signal must be isolated; S1 to S2):</b>				
for 0–90 VDC Armature Voltage			0 – 1.4 VDC	
for 0–180 VDC Armature Voltage			0 – 2.8 VDC	
<b>Decel. Time Range:</b>				
for 0–90 VDC Armature Voltage			1 – 11 seconds	
for 0–180 VDC Armature Voltage			1 – 25 seconds	
<b>Current Limit Range:</b>				
for 0–90 VDC Armature Voltage			0 – 14 A	
for 0–180 VDC Armature Voltage			0 – 13.5 A	
<b>Input Impedance (S1 to S2)</b>			3M ohms	
<b>Load Regulation</b>			1% base speed or better	
<b>Vibration</b>			1G max (0–50 Hz)	
<b>Ambient Temp. Range (cased drive)</b>			10°C–40°C	

# Dimensions

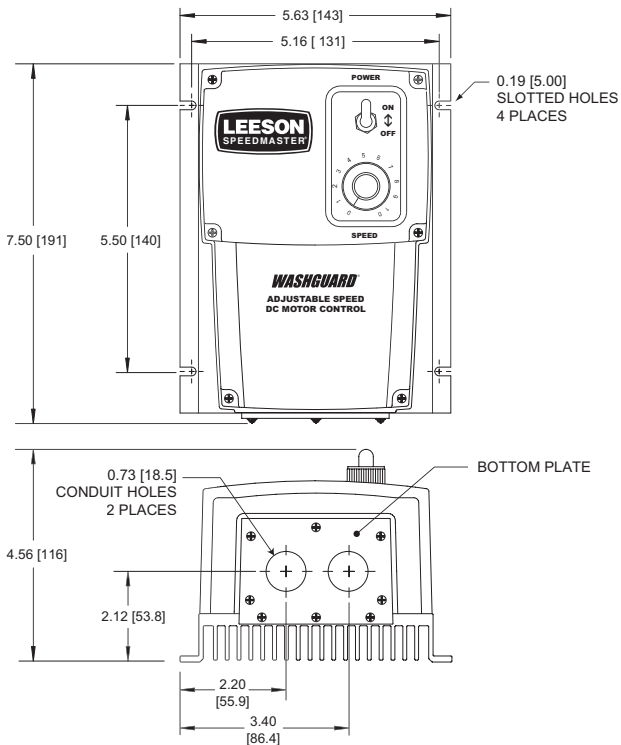

ALL DIMENSIONS IN INCHES [MILLIMETERS]

**Figure 1. 174102 & 174107 Dimensional Diagrams**

# Overview

The following is a quick-step guide to setting up the control. For more detailed installation information, read the Installation (page 4) and Calibration (page 10) sections of this user's manual.

1. **Mount** the control using the 4 slotted holes on the heat sink. The slotted holes are 0.19 inches [5 mm] (see Figure 1).
2. **Remove** the plastic cover by unscrewing the 6 screws on the front cover and 5 screws on the bottom plate. **NOTE:** Do not remove the 3 screws securing the bottom plate to the heatsink.
3. **Change** the line fuse if necessary. If the horsepower rating of the motor being used is less than the maximum HP rating of the drive, the line fuse may have to be replaced with a lower rated one.
3. **Wire** the control through the conduit holes, or optional aluminum hardware. **NOTE:** Do not connect the control while power is applied.
4. **Assure** that settings on voltage switches are correct (SW501 & SW502).
5. **Apply** power to the drive.
5. **Calibrate** the trimmer pots, if necessary.
6. **Re-install** the plastic cover.

# Installation

## Mounting

174102 and 174107 drives may be vertically wall mounted using the four 0.19 inch (5 mm) slotted holes on the attached heat sink (see Figure 1, Page 2). For motor loads less than 5 ADC, the drive may be bench mounted horizontally, or operated without mounting.

## Removing the Plastic Cover

Connections, calibration, and other settings must be made internally. After mounting, use the following procedure to remove the plastic cover and configure the control:

1. Remove the six (6) phillips screws on the front cover. NOTE: The two shorter screws (#6 - 32 x 2 ½) are for the two lower holes on the front of the cover (see Figure 2, page 6).
2. Remove the five (5) phillips screws on the bottom plate (see Figure 2, page 6). NOTE: DO NOT remove the 3 screws securing the bottom plate to the heatsink.

## Line fusing

Line fuses are preinstalled on all 174102 and 174107 drives. If the horsepower rating of the motor being used is less than the maximum horsepower rating of the drive, the line fuse may have to be replaced with a lower rated one. Refer to Table 1 for recommended line fuse sizes.

**Table 1. Recommended Line Fuse Sizes**

<b>MOTOR HP</b>	<b>FUSE SIZE (AMPS) @ 115 VAC INPUT</b>	<b>FUSE SIZE (AMPS) @ 230 VAC INPUT</b>
1/4	5	3
1/3	8	3
1/2	8	5
3/4	10	8
1	15	8
1 1/2	–	10
2	–	15

## Connections



### Warning

**Do not connect this equipment with power applied.**  
Failure to heed this directive may result in fire or serious injury.

1. Install conduit hardware through the two 0.73" (18.5 mm) conduit holes or by using aluminum cord connectors attached to the line seal plate on the bottom of the case.
2. Connect external wiring to the terminal block as shown in Figure 3, page 7.

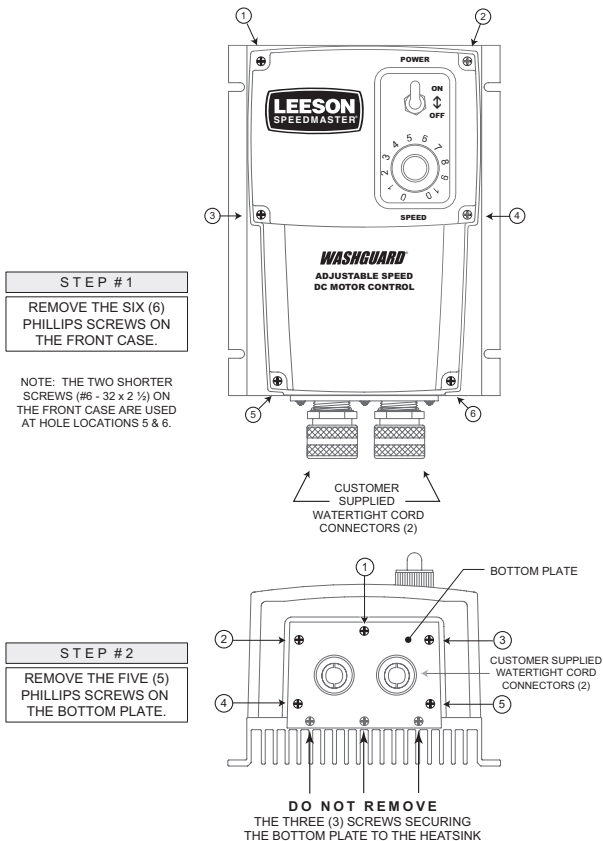

**Figure 2. Cover removal for terminal strip access**

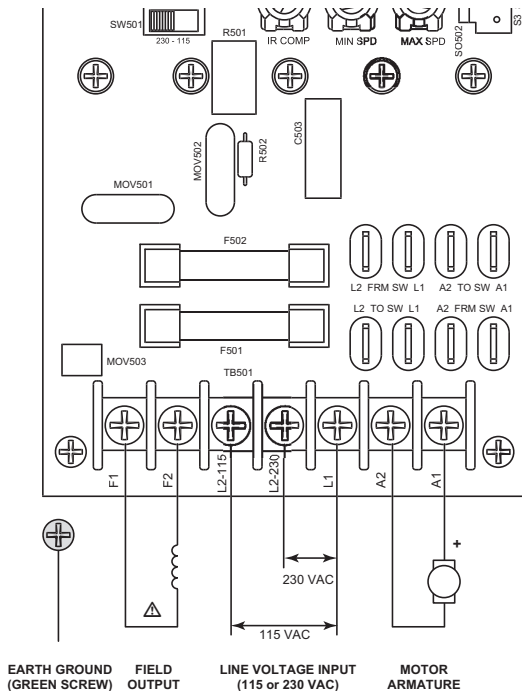

**⚠ FIELD OUTPUT CONNECTIONS ⚠**

The field output is for shunt wound motors only. Do not make any connections to F1 and F2 when using a permanent magnet motor. For field motor connections, see Table 2 on Page 8.

**Figure 3. Drive connections**

## Field Output

The field output is for shunt wound motors only. Do not make any connections to F1 and F2 when using a permanent magnet motor. Use 18 AWG wire to connect the field output to a shunt wound motor. Table 2 lists the field output connections.

**Table 2. Field Output Connections**

<b>Line Voltage (VAC)</b>	<b>Approx. Field Voltage (VDC)</b>	<b>Connect Motor Field To</b>
115	50	F1 and L1
115	100	F1 and F2
230	100	F1 and L1
230	200	F1 and F2

## Voltage Switches

- Set voltage switch SW501 to either 115 or 230 to match the AC line voltage (see Figure 4, page 9).
- Set voltage switch SW502 to either 90 or 180 to match the maximum armature voltage (see Figure 4, page 9).

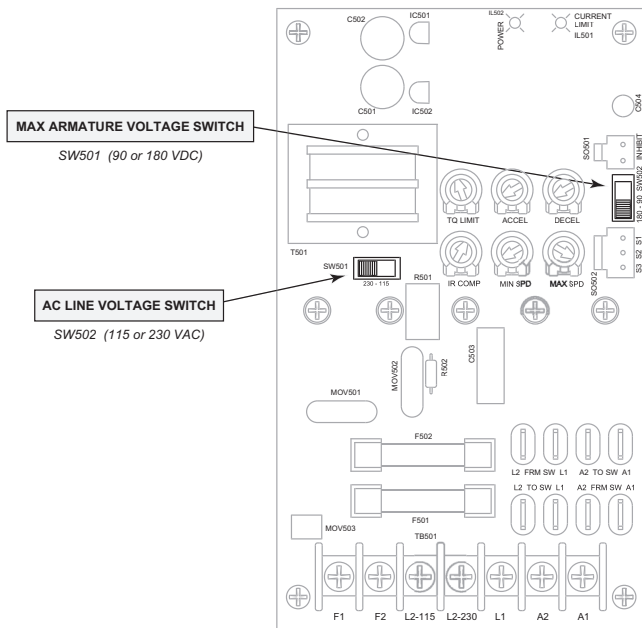
**Figure 4. Voltage Switches**

# Calibration



## Warning

Dangerous voltages exist on the drive when it is powered. When possible, disconnect the voltage input from the drive before adjusting the trimpots. If the trimpots must be adjusted with power applied, use insulated tools and the appropriate personal protection equipment. **BE ALERT.** High voltages can cause serious or fatal injury.

All drives have six user-adjustable trimpots: Torque Limit (TORQUE), Acceleration (ACCEL), Deceleration (DECEL), Regulation (IR COMP), Minimum Speed (MIN SPD), and Maximum Speed (MAX SPD). Each drive is factory calibrated to its maximum current rating. Readjust the calibration trimpot settings to accommodate lower current rated motors.

All adjustments increase with CW rotation, and decrease with CCW rotation. Use a non-metallic screwdriver for calibration. Each trimpot is identified on the printed circuit board. Refer to Figure 5 (page 11) for trimpot locations and Figure 6 (page 16) for typical TORQUE LIMIT and IR COMP settings.

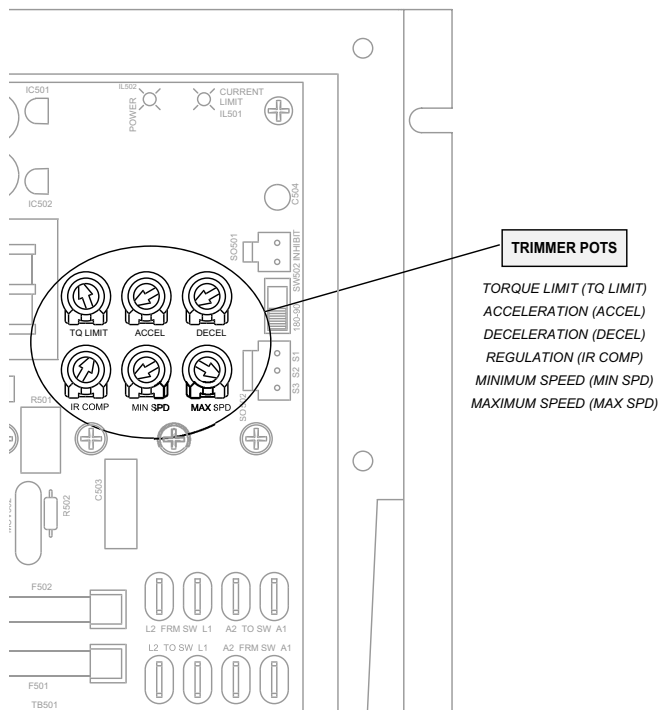

**Figure 5. Calibration Trimpot Layout**

## Calibration procedure

Calibrate the drive using the following procedure:

1. Set the MIN SPD, IR COMP, ACCEL and DECEL trimpots to zero (full CCW).
2. Set the TORQUE trimpot to maximum (full CW).
3. Set the MAX SPD trimpot to midrange (approximate 12 o'clock position).
4. Turn the speed adjust potentiometer on front cover to zero.
5. Apply power to the drive.
6. Calibrate the trimpots as follows:

### MINIMUM SPEED (MIN SPD)

The MIN SPD setting determines the motor speed when the speed adjust potentiometer is turned full CCW. It is factory set to zero speed.

To calibrate, turn the speed adjust potentiometer full CCW. Adjust the MIN SPD trimpot until the motor has stopped, or is running at the desired minimum speed.

## MAXIMUM SPEED (MAX SPD)

The MAX SPD setting determines the motor speed when the speed adjust potentiometer is turned full CW. It is factory set for maximum rated speed.

To calibrate, set the MAX SPD trimpot full CCW. Turn the speed adjust potentiometer full CW. Adjust the MAX SPD trimpot until the desired maximum motor speed is reached.

Note: Check the MIN SPD and MAX SPD adjustments after recalibrating to verify that the motor runs at the desired minimum and maximum speed.

## REGULATION (IR COMP)

The IR COMP setting determines the degree to which motor speed is held constant as the motor load changes. It is factory set for optimum motor regulation.

Recalibrate the IR COMP setting when using a lower horsepower motor. Refer to the recommended IR COMP settings in Figure 9 (page 16), or recalibrate using the following procedure:

If the motor does not maintain set speed as the load changes, gradually rotate the IR COMP trimpot CW. If the motor oscillates (overcompensation), the IR COMP trimpot may be set too high. Turn the IR COMP trimpot CCW to stabilize the motor.

## TORQUE LIMIT (TORQUE)



### Warning

Although TORQUE is set to 150% of drive nameplate current rating, continuous operating beyond that rating may damage the motor. If you intend to operate beyond the rating, contact your LEESON representative for assistance.

The TORQUE setting determines the maximum torque for accelerating and driving the motor. TORQUE is factory set at 150% of maximum drive current. You must recalibrate the TORQUE setting if using a lower current rated motor. See Figure 9 (page 16) for typical TORQUE and IR COMP settings.

1. With no power applied to the drive, connect a DC ammeter in series with the motor armature.
2. Set the TORQUE trimpot to full CCW.
3. Carefully lock the motor armature. Ensure that the motor is firmly mounted.
4. Apply line power. The motor should be stopped.
5. Set the speed potentiometer or reference signal to maximum speed. The motor should remain stopped.
6. Slowly rotate the TORQUE trimpot clockwise (CW) until the ammeter reads 150% of maximum motor armature current.
7. Set the speed adjust potentiometer or reference signal to zero speed.

8. Remove power from the drive.
9. Remove the lock from the motor shaft.
10. Remove the ammeter in series with the motor armature.

## ACCELERATION (ACCEL)

The ACCEL setting determines the time the motor takes to ramp to a higher speed. See **Specifications** on page 1 for approximate acceleration times. The ACCEL setting is factory set to its minimum value (full CCW).

Turn the ACCEL trimpot CW to increase the acceleration time, and CCW to decrease the acceleration time.

## DECELERATION (DECEL)

The DECEL setting determines the time the motor takes to ramp to a lower speed. See **Specifications** on page 1 for approximate deceleration times. The DECEL setting is factory set to its minimum value (full CCW).

Turn the DECEL trimpot CW to increase the deceleration time, and CCW to decrease the deceleration time.

## Calibration procedure conclusion

This concludes the calibration procedure. The control should now be calibrated for optimum operation.

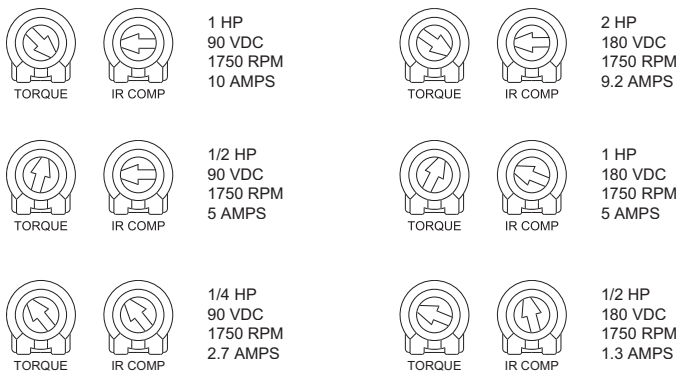

**Figure 6. Recommended TORQUE and IR COMP Settings for 174102 & 174107 Controls**

# Operation



## Warning

Change voltage switch settings only when the drive is disconnected from AC line voltage. Make sure both switches are set to their correct position. If the switches are improperly set to a lower voltage position, the motor will not run at full voltage. If the switches are improperly set to a higher voltage position, the motor will overspeed, which may cause motor damage.

## Before applying power

- Set voltage switch SW501 to either 115 or 230 to match the AC line voltage (see Figure 4, page 9).
- Set voltage switch SW502 to either 90 or 180 to match the maximum armature voltage (see Figure 4, page 9).
- Verify that no conductive material is present on the printed circuit board.
- If using a 90 VDC or 130 VDC motor with 230 VAC line voltage, derate the nameplate motor speed and torque by at least 30%.

## Startup



### Warning

If the motor or drive does not perform as described in this section, disconnect the AC line voltage immediately. Refer to ***Troubleshooting***, page 33, for further assistance.

## 174102

1. Set the speed adjust potentiometer (SPEED dial) to “0”, or full CCW.
2. Apply AC line voltage.
3. Set the POWER switch to the ON position.
4. Slowly advance the speed adjust potentiometer CW. The motor slowly accelerates as the potentiometer is turned CW. Likewise, the motor slowly decelerates as the potentiometer is turned CCW. Continue until the desired speed is reached.
5. To coast the motor to a stop, turn the speed adjust potentiometer to “0” or set the POWER switch to the OFF position.

**174107****Warning**

Do not change the FORWARD / OFF / REVERSE switch while the motor is running. The motor must come to a complete stop before reversing. Changing motor direction before allowing the motor to completely stop will cause excessively high current to flow in the armature circuit, and may damage the drive and/or motor.

1. Set the FORWARD/OFF/REVERSE switch to the OFF position.
2. Set the speed adjust potentiometer (SPEED dial) to “0”, or full CCW.
3. Apply AC line voltage.
4. Set the FORWARD/OFF/REVERSE switch to the desired direction of rotation.
5. Slowly advance the speed adjust potentiometer CW. The motor slowly accelerates as the potentiometer is turned CW. Likewise, the motor slowly decelerates as the potentiometer is turned CCW. Continue until the desired speed is reached.
6. To coast the motor to a stop, turn the speed adjust potentiometer to “0” or set the FORWARD/OFF/REVERSE switch to the OFF position.
7. To reverse direction:
  - a. Set the FORWARD/OFF/REVERSE switch to the OFF position.
  - b. After the motor comes to a complete stop, set the FORWARD/OFF/REVERSE switch to the desired direction of rotation.

# Application Notes



## Warning

Decelerating to minimum speed, inhibit operation, or coasting to a stop is recommended for frequent starts and stops. Do not use any of these methods for emergency stopping. They may not stop a drive that is malfunctioning. Removing AC line power (both L1 and L2) is the only acceptable method for emergency stopping.

## Inhibit circuit

Maintaining a connection between the inhibit pins (Figure 7, page 21) causes the motor to coast to minimum speed. Removing the connection between the inhibit pins allows the motor to accelerate to the speed set by the speed adjust potentiometer.

LEESON offers an accessory plug harness for connecting to the INHIBIT terminals: part number 900282.01 [inhibit plug with 18 inches (46 cm) leads].

Twist inhibit wires and separate them from other power-carrying wires or sources of electrical noise. Use shielded cable if the inhibit wires are longer than 18 inches (46 cm). If shielded cable is used, ground only one end of the shield to earth ground. Do not ground both ends of the shield.

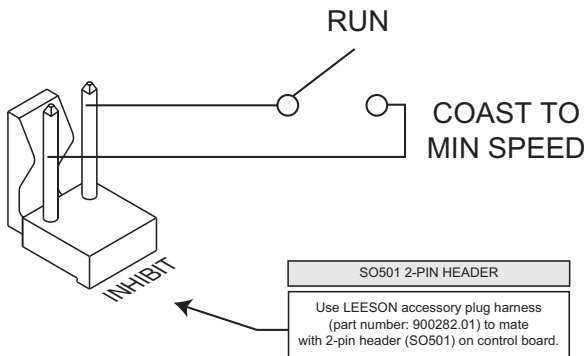

**Figure 7. Inhibit Plug with Run/Coast to Minimum Speed**

## Decelerating to minimum speed

The switch shown in Figure 8 may be used to decelerate a motor to minimum speed. Closing the switch between S1 and S2 decelerates the motor from set speed to minimum speed determined by the MIN SPD trimpot setting. If the MIN SPD trimpot is set full CCW, the motor decelerates to zero speed when the switch between S1 and S2 is closed. The DECEL trimpot setting determines the rate at which the drive decelerates. By opening the switch, the motor accelerates to set speed at a rate determined by the ACCEL trimpot setting.

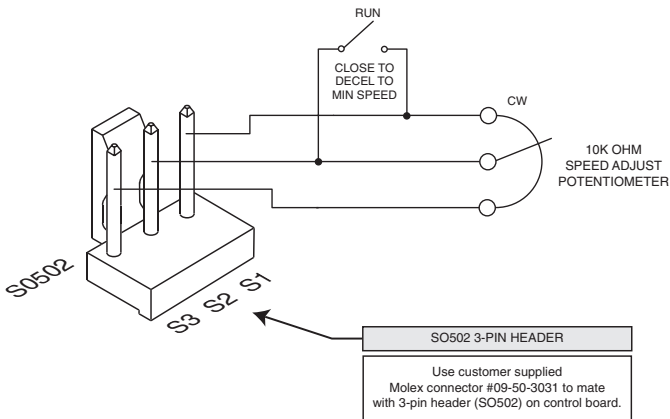

**Figure 8. Run/Decelerate to Minimum Speed Switch**

## Dynamic Braking



### Warning

Wait for the motor to completely stop before switching it back to the RUN position. This will prevent high armature currents from damaging the motor or drive.

Dynamic braking may be used to rapidly stop a motor (Figure 9, page 24). For the RUN/BRAKE switch, use a two-pole, two-position switch rated for at least the maximum DC armature voltage and maximum braking current. For the dynamic brake resistor, use a 40 watt minimum, high power, wirewound resistor.

Sizing the dynamic brake resistor depends on load inertia, motor voltage, and braking time. Use a lower-value, higher-wattage dynamic brake resistor to stop a motor more rapidly.

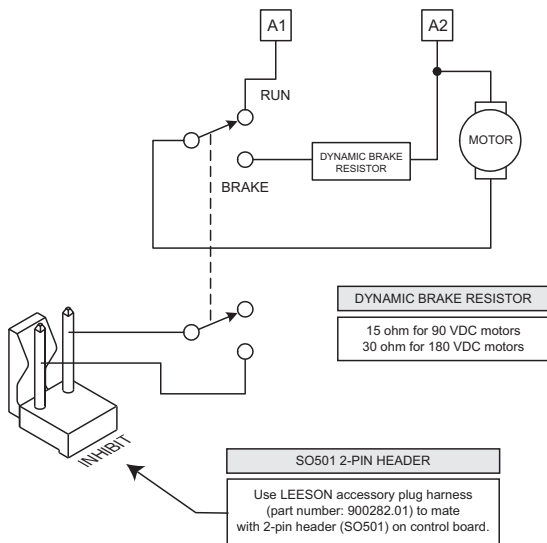

**Figure 9. Dynamic Brake Connection**

## Multiple Fixed Speeds

Replace the speed adjust potentiometer with series resistors with a total series resistance of 10K ohms (Figure 10). Add a single-pole, multi-position switch with the correct number of positions for the desired number of fixed speeds.

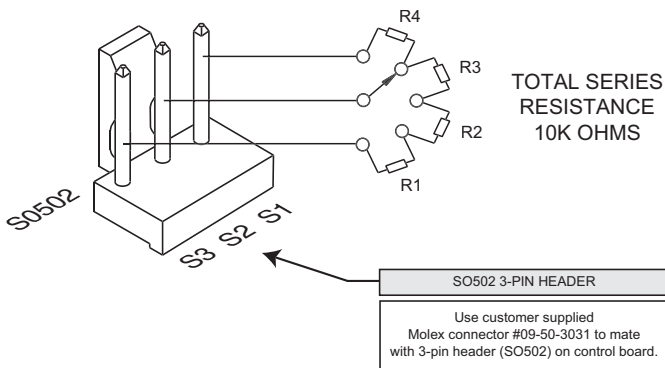

Figure 10. Multiple Fixed Speeds

## Adjustable speeds using potentiometers in series

Replace the speed adjust potentiometer with a single-pole, multi-position switch, and two or more potentiometers in series, with a total series resistance of 10K ohms. Figure 11 shows a connection for fixed high and low speed adjust potentiometers.

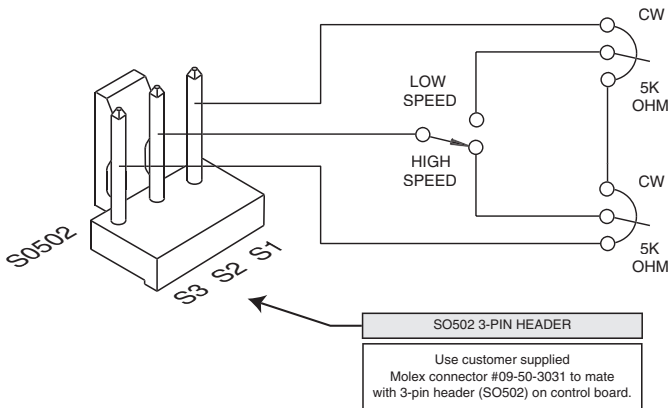
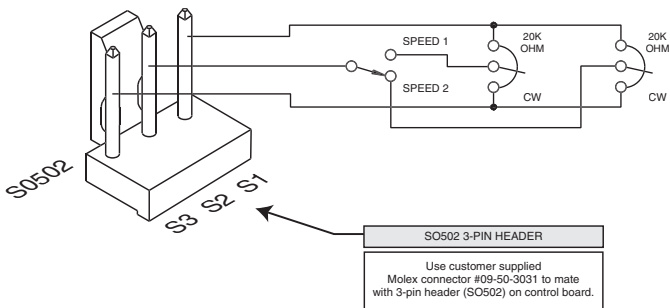

Figure 11. Adjustable Fixed Speeds Using Potentiometers in Series

## Independent adjustable speeds

Replace the speed adjust potentiometer with a single pole, multi-position switch, and two or more potentiometers in parallel, with a total parallel resistance of 10K ohms. Figure 12 shows the connection of two independent speed adjust potentiometers that can be mounted at two separate operating stations.



**Figure 12. Independent Adjustable Speeds**

## RUN/JOG switch

Using a RUN/JOG switch is recommended in applications where quick stopping is not needed and frequent jogging is required. Use a single pole, two position switch for the RUN/JOG switch, and a single pole, normally closed, momentary operated pushbutton for the JOG pushbutton.

### RUN/JOG option #1

In the first wiring option, connect the RUN/JOG switch and JOG pushbutton to the inhibit plug as shown in Figure 13. The motor coasts to minimum speed when the RUN/JOG switch is set to JOG. Press the JOG pushbutton to jog the motor. Return the RUN/JOG switch to RUN for normal operation.

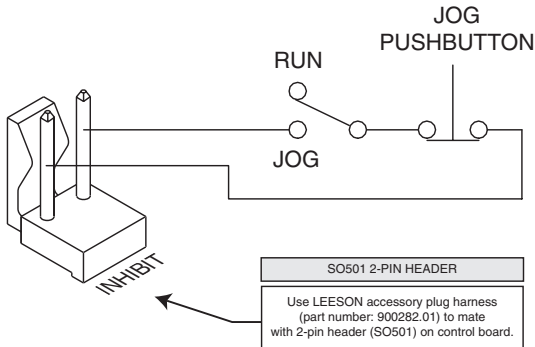

**Figure 13. RUN/JOG Switch Option #1**

## RUN/JOG option #2

In the second wiring option, connect the RUN/JOG switch and the JOG pushbutton as shown in Figure 14. When the RUN/JOG switch is set to JOG, the motor decelerates to minimum speed (minimum speed is determined by the MIN SPD trimpot setting). Press the JOG pushbutton to jog the motor. Return the RUN/JOG switch to RUN for normal operation.

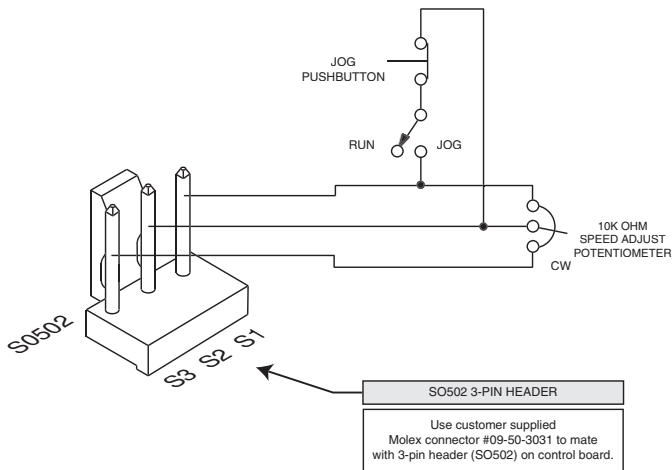

**Figure 14. RUN/JOG Switch Connection to Speed Adjust Potentiometer**

## Leader-follower application

In this application, use a 174335 Process Control Module (PCM) to monitor the speed of the leader motor (Figure 15). The PCM isolates the leader motor from the follower drive, and outputs a voltage proportional to the leader motor armature voltage. The follower drive uses this voltage reference to set the speed of the follower motor. An optional ratio potentiometer may be used to scale the PCM output voltage.

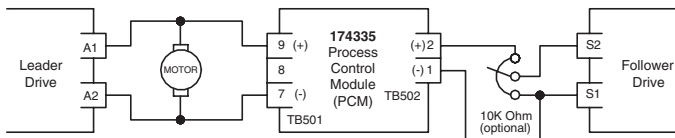

**Figure 15. Leader-Follower Application**

## Single speed potentiometer control of multiple drives

Multiple drives can be controlled with a single speed adjust potentiometer using a 174335 Process Control Module (PCM) at the input of each drive to provide isolation (Figure 16). Optional ratio potentiometers can be used to scale the PCM output voltage, allowing independent control of each drive.

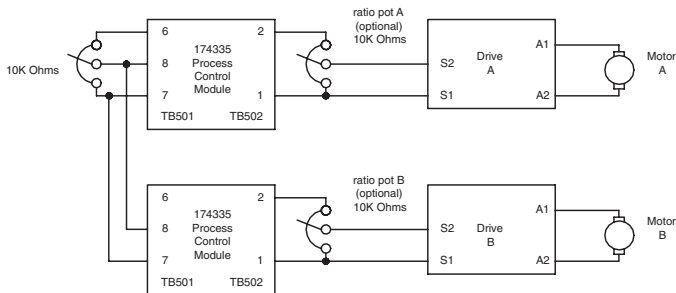

**Figure 16. Single Speed Potentiometer Control of Multiple Drives**

## Reversing

A dynamic brake may be used when reversing the motor direction (Figure 17). Use a three-pole, three-position switch rated for at least the maximum DC armature voltage and maximum braking current. Wait for the motor to stop completely before switching it to either the forward or reverse direction. See the dynamic braking section, page 22, for recommended dynamic brake resistor sizes. NOTE: Model 174107 is equipped with the reversing feature, but not the dynamic brake feature.

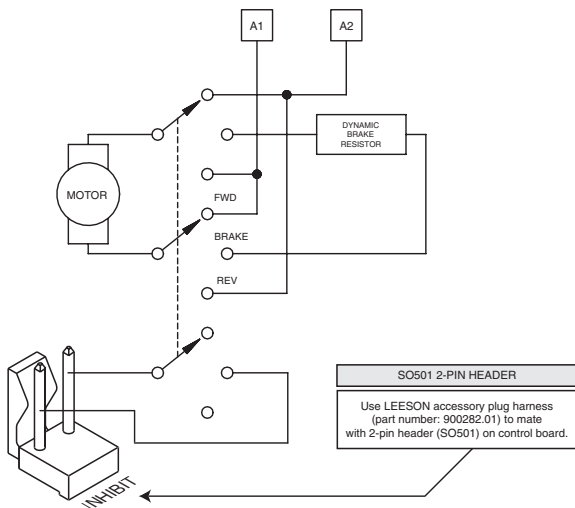

**Figure 17. Reversing Circuit Connection**

# Troubleshooting



## Warning

Dangerous voltages exist on the drive when it is powered. When possible, disconnect the drive while troubleshooting. High voltages can cause serious or fatal injury.

## Before troubleshooting

Perform the following steps before starting any procedure in this section:

- Disconnect AC line voltage from the drive.
- Check the drive closely for damaged components.
- Check that no conductive or other foreign material has become lodged on the printed circuit board.
- Verify that every connection is correct and in good condition.
- Verify that there are no short circuits or grounded connections.
- Check that the voltage switch settings match the AC line and maximum armature output voltages.
- Check that the drive's rated armature outputs are consistent with the motor ratings.

## Power and Current Limit LEDs

174102 & 174107 drives are equipped with a green, PCB-mounted power LED and a red, PCB-mounted current limit LED.

### POWER LED (IL502)

The green power LED turns on when AC line voltage is applied to the drive.

### CURRENT LIMIT (IL501)

The red current limit LED turns on when the drive reaches current limit and turns off whenever the drive is not in current limit (normal operation).

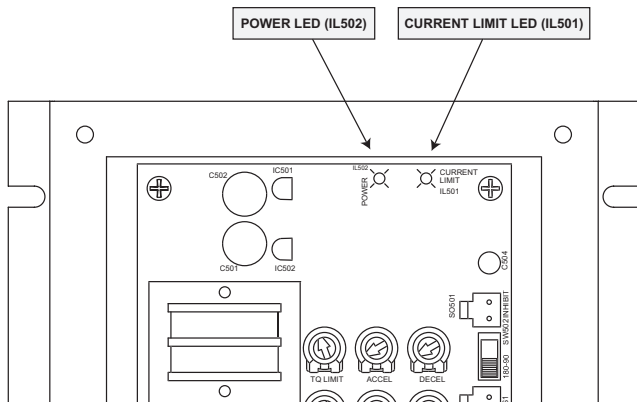

Figure 18. Current Limit LED

<b>Symptom</b>	<b>Possible Causes</b>	<b>Suggested Solutions</b>
Fuse blows or circuit breaker trips	<ol style="list-style-type: none"><li>1. Line fuses or circuit breakers are the wrong size.</li><li>2. Motor cable or armature is shorted to ground.</li><li>3. Nuisance tripping caused by a combination of ambient conditions and high-current spikes.</li></ol>	<ol style="list-style-type: none"><li>1. Check that line fuses or circuit breakers are the proper size.</li><li>2. Check motor cable and armature for shorts.</li><li>3. Add a blower to cool the drive components; decrease TORQUE settings, <b>or</b> resize motor and drive for actual load demand, <b>or</b> check for incorrectly aligned mechanical components or “jams”. See page 14 for information on adjusting the TORQUE trimpot.</li></ol>
Line fuse does not blow or circuit breaker does not trip, but the motor does not run	<ol style="list-style-type: none"><li>1. Reference signal or speed adjust pot is set to zero speed.</li><li>2. Reference signal or speed adjust potentiometer connections are open.</li></ol>	<ol style="list-style-type: none"><li>1. Increase reference signal or speed adjust potentiometer setting.</li><li>2. Check that the reference signal or speed adjust potentiometer connections are not open.</li></ol>

<b>Symptom</b>	<b>Possible Causes</b>	<b>Suggested Solutions</b>
Line fuse does not blow or circuit breaker does not trip, but the motor does not run (cont.)	<ol style="list-style-type: none"> <li>3. Drive is in current limit.</li> <li>4. Drive is not receiving AC line voltage.</li> <li>5. Motor is not connected.</li> </ol>	<ol style="list-style-type: none"> <li>3. Verify that the motor is not jammed. Increase TORQUE setting (page 14).</li> <li>4. Apply AC line voltage to L1 and L2.</li> <li>5. Connect motor to A1 and A2.</li> </ol>
Motor runs too fast at maximum speed setting	<ol style="list-style-type: none"> <li>1. MIN SPD and MAX SPD settings are too high.</li> </ol>	<ol style="list-style-type: none"> <li>1. Recalibrate MIN SPD (page 12) and MAX SPD (page 13).</li> </ol>
Motor runs too slow or too fast	<ol style="list-style-type: none"> <li>1. MIN SPD and MAX SPD are not calibrated.</li> </ol>	<ol style="list-style-type: none"> <li>1. Recalibrate MIN SPD (page 12) and MAX SPD (page 13).</li> </ol>
Motor will not reach the desired speed.	<ol style="list-style-type: none"> <li>1. MAX SPD setting is too low.</li> <li>2. IR COMP setting is too low.</li> <li>3. Motor is overloaded.</li> </ol>	<ol style="list-style-type: none"> <li>1. Increase MAX SPD setting (page 13).</li> <li>2. Increase IR COMP setting (page 13).</li> <li>3. Check motor load. Resize the motor or drive if necessary.</li> </ol>

<b>Symptom</b>	<b>Possible Causes</b>	<b>Suggested Solutions</b>
Motor pulsates or surges under load	<ol style="list-style-type: none"><li>1. IR COMP is set too high.</li><li>2. Control is in current limit mode.</li></ol>	<ol style="list-style-type: none"><li>1. Adjust the IR COMP setting slightly CCW until the motor speed stabilizes (page 13).</li><li>2. Check that motor is of sufficient horsepower and amperage.</li></ol>
On non-reversing drives, motor runs in the opposite direction	<ol style="list-style-type: none"><li>1. Motor armature leads are reversed.</li></ol>	<ol style="list-style-type: none"><li>1. Reverse connections to the motor armature.</li></ol>
Motor will not stop when the speed adjust potentiometer or reference signal is set to zero speed.	<ol style="list-style-type: none"><li>1. MIN SPD trimpot is not adjusted properly.</li></ol>	<ol style="list-style-type: none"><li>1. Slowly rotate the MIN SPD trimpot until the motor stops.</li></ol>

## Replacement Parts

Table 3 is provided as a guide for some component parts that may require replacement. These items are not available from LEESON. They are readily available from suppliers of electronic components. Replacing these items on drives that are under warranty will void the warranty.



### Warning

Dangerous voltages exist on the drive when it is powered. Disconnect power from the drive and allow time for the voltage on the capacitors to dissipate before working on the drive. Use insulated tools and the appropriate personal protection equipment. BE ALERT. High voltages can cause serious or fatal injury.

**Table 3. Replacement Parts**

<b>Model No.</b>	<b>Symbol</b>	<b>Description</b>
174102	SCR501, 502	800 V, 20 A SCR
	D501-503	800 V, 20 A Diode
	R501	0.01 OHM, 5 W Resistor
174107	SCR501, 502	800 V, 20 A SCR
	D501-503	800 V, 20 A Diode
	R501	0.01 OHM, 5 W Resistor

# NOTES

# NOTES

# NOTES

## **DISCLAIMER**

The information and technical data in this manual are subject to change without notice. LEESON Electric makes no warranty of any kind with regard to this material, including, but not limited to, the implied warranties of merchantability and fitness for a particular purpose. LEESON Electric assumes no responsibility for any errors that may appear in this manual and makes no commitment to update or to keep current the information in this manual.



2100 Washington Street  
GRAFTON, WI 53024-0241 U.S.A.  
TEL: (262) 377-8810  
FAX: (262) 377-9025

Doc # 250-0341, Revision 0  
September 2002  
Printed in the U.S.A