



USER'S MANUAL

DC Series

Pulse-Width Modulated,
Adjustable Speed Drives
for DC Brush Motors

Models:

DC16-12/24

DC60-12/24

DC60-36/48

The Minarik DC Series drives are chassis drives that accept a DC input voltage and output a DC power voltage to control the speed of a low voltage motor. The speed may be controlled with a potentiometer or an external voltage signal.

Standard Features:

- Provides smooth variable capability for mobile equipment.
- Maintains variable speed control as batteries discharge.
- Adjustable min speed, max speed, IR compensation, current limit, and accel.
- Inhibit terminal permits optional start-stop without breaking battery lines.
- Speed potentiometer included.
- Increases range or running time of battery operated equipment through high efficiency.
- Power LED gives a visual indication when power is applied to the drive.
- Jumper reconnectable for low or high voltage.

Copyright © 2002 by
Minarik Corporation

All rights reserved. No part of this manual may be reproduced or transmitted in any form without written permission from Minarik Corporation. The information and technical data in this manual are subject to change without notice. Minarik Corporation and its Divisions make no warranty of any kind with respect to this material, including, but not limited to, the implied warranties of its merchantability and fitness for a given purpose. Minarik Corporation and its Divisions assume no responsibility for any errors that may appear in this manual and make no commitment to update or to keep current the information in this manual.

Printed in the United States of America.

Safety Warnings



- This symbol  denotes an important safety tip or warning. **Please read these instructions carefully** before performing any of the procedures contained in this manual.
- **DO NOT INSTALL, REMOVE, OR REWIRE THIS EQUIPMENT WITH POWER APPLIED.** Minarik assumes the qualified technician is intimate with the dangers involving batteries, especially lead-acid type. This manual presupposes that you have taken all the necessary precautions to prevent a potentially fatal accident involving such batteries, and have followed all standard electrical precautions.
- Reduce the chance of an electrical fire, shock, or explosion by proper grounding, over-current protection, thermal protection, and enclosure. Follow sound maintenance procedures.



It is possible for a drive to run at full speed as a result of a component failure. Minarik strongly recommends the installation of a master switch in the main power input to stop the drive in an emergency.

This drive is isolated from earth ground. Avoid direct contact with the printed circuit board or with circuit elements to prevent the risk of serious injury or fatality. Use a non-metallic screwdriver for adjusting the calibration trimpots. Use approved personal protective equipment and insulated tools if working on this drive with power applied.

Contents

Safety Warnings	i
Specifications	1
Dimensions	2
Installation	4
Mounting	4
Wiring	5
Heat sinking	7
Fuse / Circuit breaker protection	7
Jumper 501 (JP501)	8
Speed adjust potentiometer	9
Connections	11
Voltage follower	14
Operation	15
Before applying power	15
Startup and shutdown	16
Starting and stopping methods	17
Inhibit terminals	19
Power LED (IL501)	20
Calibration	21
MINIMUM SPEED (MIN SPD)	22
MAXIMUM SPEED (MAX SPD)	22
ACCELERATION (ACCEL)	23
IR COMPENSATION (IR COMP)	24
CURRENT LIMIT (CUR LIMIT)	25

Application Notes	27
Multiple fixed speeds27
Adjustable speeds using potentiometers in series28
Independent adjustable speeds29
RUN/JOG switch30
Reversing31
Troubleshooting	33
Before troubleshooting33
Unconditional Warranty	inside back cover

Illustrations

Figure 1. DC16-12/24 Dimensions2
Figure 2. DC-12/24 and DC60-36/48 Dimensions3
Figure 3. Heatsink mounting7
Figure 4. Jumper 501 (JP501)8
Figure 5. Speed Adjust Potentiometer10
Figure 6. Speed Adjust Potentiometer Connections10
Figure 7. Power, Fuse and Motor Armature Connections13
Figure 8. Voltage Follower Connections14
Figure 9. Run/Decelerate to Minimum Speed Switch18
Figure 10. Inhibit Terminals19
Figure 11. Power LED20
Figure 12. Calibration Trimpot Layout21
Figure 13. Approximate CUR LIMIT Settings26
Figure 14. Multiple Fixed Speeds27
Figure 15. Adjustable Fixed Speeds Using Potentiometers in Series28
Figure 16. Independent Adjustable Speeds29
Figure 17. RUN/JOG Switch Connection to Speed Adjust Potentiometer30
Figure 18. Reversing hookup diagram32

Tables

Table 1. Wire Gauge/Length Chart5
--	----

Specifications

Model	Max. Armature Current (Amps DC)	Max. Armature Voltage ³ (VDC)	DC Voltage Input Range (VDC)
DC16-12/24	16 ¹	12 or 24 ²	10–32
DC60-12/24	60	12 or 24 ²	10–32
DC60-36/48	60	36 or 48 ²	32–50

Acceleration Time Range	0.5 – 10 seconds
Deceleration Time	0.5 seconds
Analog Input Voltage Range (signal must be isolated; S1 to S2)	0 – 10 VDC
Input Impedance (S1 to S2)	200KΩ
Speed Regulation (% of base speed)	1%
Speed Range	80:1
Form Factor	1.01
Ambient Operating Temperature Range	10°C – 40°C
Weight	
DC16-12/24	1.7 lbs.
DC60-12/24	3.6 lbs.
DC60-36/48	3.6 lbs.

- 1 At 40°C ambient. No additional heat sink is necessary.
- 2 Or up to 95% of available battery voltage.
- 3 The lower maximum armature voltage is selectable by connecting a jumper to pins 2 and 3 of JP501 (see page 8).

Dimensions

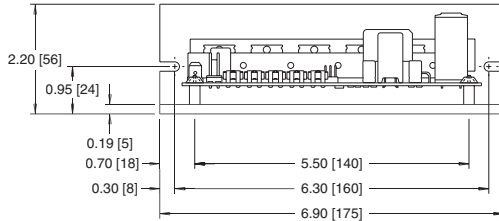
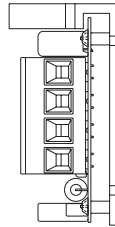
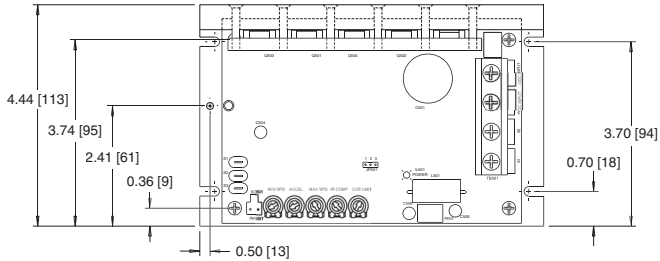

ALL DIMENSIONS IN
INCHES
[MILLIMETERS]

Figure 1. DC16-12/24 Dimensions

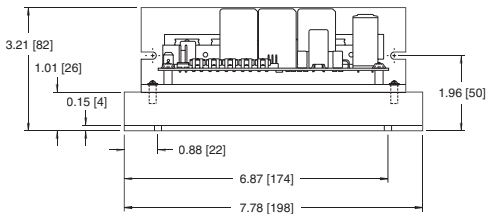
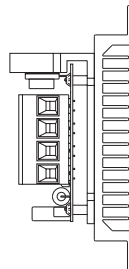
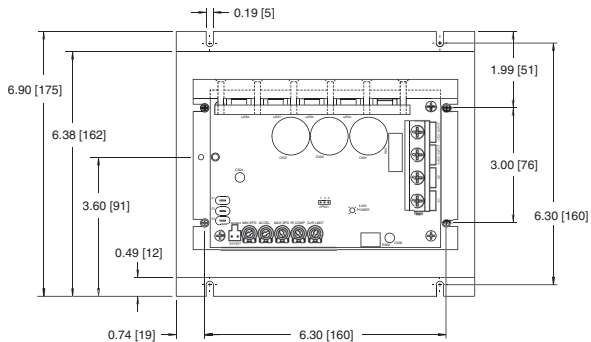

ALL DIMENSIONS IN
INCHES
[MILLIMETERS]

Figure 2. DC-12/24 and DC60-36/48 Dimensions

Installation

Mounting



Warning

Do not install, rewire, or remove this control with input power applied. Doing so may cause fire or serious injury. Make sure you have read and understood the Safety Warnings on page i before attempting installation.

- Drive components are sensitive to electrostatic fields. Avoid contact with the circuit board directly. Hold drive by the chassis only.
- Protect the drive from dirt, moisture, and accidental contact.
- Provide sufficient room for access to the terminal block and calibration trimpots.
- Mount the drive away from other heat sources. Operate the drive within the specified ambient operating temperature range.
- Prevent loose connections by avoiding excessive vibration of the drive.
- Mount drive with its board in either a horizontal or vertical plane. Six 0.19 in. (5 mm) wide slots in the chassis accept #8 pan head screws. Fasten either the large base or the narrow flange of the chassis to the subplate.

Wiring



Warning



Do not install, remove, or rewire this equipment with power applied. Failure to heed this warning may result in fire, explosion, or serious injury.

This drive is isolated from earth ground. To prevent the risk of injury or fatality, avoid direct contact with the printed circuit board or with circuit elements.

Do not disconnect any of the motor leads from the drive unless power is removed. Opening any one motor lead may destroy the drive.

This drive is not diode-protected from reverse battery voltage. You must assure that POS (+) is wired to +VDC IN and NEG (-) is wired to -VDC IN.

Use 18 AWG wire for speed adjust potentiometer wiring.

- Size the DC voltage input and motor wire according to the following chart:

Table 1. Wire Gauge/Length Chart

Armature Current (amps)	Wire Gauge (AWG)	Maximum Wire Length (feet)
0 – 19	14	8
20 – 32	10	10
60	8	10

Shielding guidelines



Warning

Under no circumstances should power and logic leads be bundled together. Induced voltage can cause unpredictable behavior in any electronic device, including motor controls.

As a general rule, Minarik recommends shielding of all conductors.

If it is not practical to shield power conductors, Minarik recommends shielding all logic-level leads. If shielding of logic level leads is not practical, the user should twist all logic leads with themselves to minimize induced noise.

It may be necessary to earth ground the shielded cable. If noise is produced by devices other than the drive, ground the shield at the drive end. If noise is generated by a device on the drive, ground the shield at the end away from the drive. Do not ground both ends of the shield.

If the drive continues to pick up noise after grounding the shield mount the drive in a less noisy environment.

Logic wires from other input devices, such as motion controllers and PLL velocity controllers, must be separated from power lines in the same manner as the logic I/O on this drive.

Heat sinking

DC60-12/24 and DC60-36/48 drives are pre-mounted on heat sink part number 223-0434. For optimum heat transfer, mount the drive with heatsink fins standing vertically as shown in Figure 3 below.

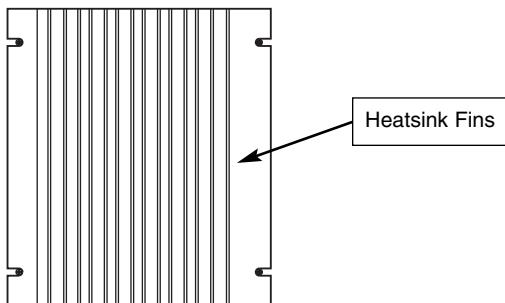

Figure 3. Heatsink mounting

Fuse / Circuit breaker protection

All Minarik drives should be protected by a fuse or circuit breaker. Use a fast acting fuse or circuit breaker rated for approximately 200% of the maximum armature current and armature voltage. Connect the fuse or circuit breaker to the VDC+ IN side of the DC voltage input.

Jumper 501 (JP501)

Minarik DC series drives are shipped with JP501 open (no jumper applied). This allows you to use 24 VDC motors with the DC16-12/24 and DC60-12/24, or 48 VDC motors with the DC60-36/48. To use lower voltage DC motors (12 VDC or 36 VDC, respectively) jumper pins 2 and 3 with the jumper provided. See Figure 4 for the location of JP501.

DC16-12/24 = 16 Amp 12/24 VDC
 DC60-12/24 = 60 Amp 12/24 VDC
 DC60-36/48 = 60 Amp 36/48 VDC

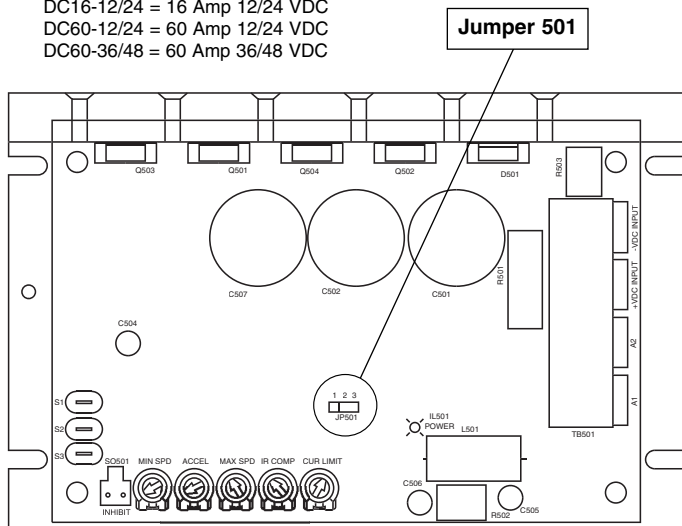

Figure 4. Jumper 501 (JP501)

Speed adjust potentiometer



Warning

Be sure that the potentiometer tabs do not make contact with the potentiometer enclosure. Grounding the input will cause damage to the drive.

Mount the speed adjust potentiometer through a 0.38 in. (10 mm) hole with the hardware provided (see Figure 5 on Page 10). Install the circular insulating disk between the panel and the 10K ohm speed adjust potentiometer.

Twist the speed adjust potentiometer wire to avoid picking up unwanted electrical noise. If speed adjust potentiometer wires are longer than 18 in. (457 mm), use shielded cable. Keep speed adjust potentiometer wires separate from power leads (L1, L2, A1, A2).

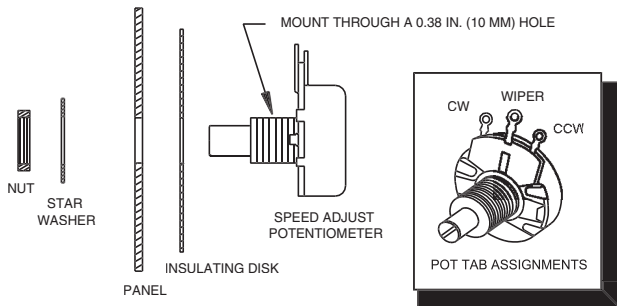

Figure 5. Speed Adjust Potentiometer

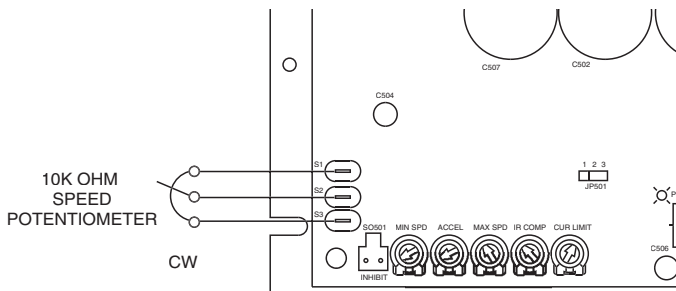

Figure 6. Speed Adjust Potentiometer Connections

Connections



Warning

Do not connect this equipment with power applied.

Failure to heed this directive may result in fire or serious injury.

Minarik strongly recommends the installation of a master power switch in the voltage input line, as shown in Figure 7, page 13. The switch contacts should be rated at a minimum of 200% of motor nameplate current and 150% of the input voltage.

Power, fuse and motor connections

Connect the power input leads, an external line fuse and a motor to the drive's printed circuit board (PCB) as shown in Figure 7, page 13.

Motor

Minarik drives supply motor voltage from A1 and A2 terminals. It is assumed throughout this manual that, when A1 is positive with respect to A2, the motor will rotate clockwise (CW) while looking at the output shaft protruding from the front of the motor. If this is opposite of the desired rotation, simply reverse the wiring of A1 and A2.

Connect a DC motor to PCB terminals A1 and A2 as shown in Figure 7, page 13. **Ensure that the motor voltage rating is consistent with the drive's output voltage.**

Power input



Warning

This drive is not diode-protected from reverse battery voltage. You must assure that POS (+) is wired to +VDC IN and NEG (-) is wired to -VDC IN.

Connect the DC power leads to terminals + VDC IN and - VDC IN, or to a single-throw, single-pole master power switch as shown in Figure 7, page 13 (recommended).

Fuse

Wire a power input fuse between the stop switch (if installed) and the + VDC IN terminal on the circuit board. The fuse should be rated at 150% of input voltage and 150 - 200% of maximum motor nameplate current.

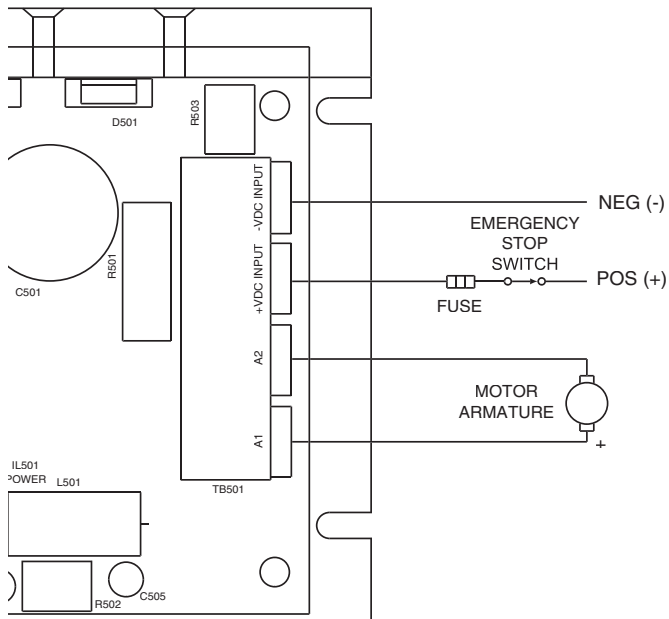

Figure 7. Power, Fuse and Motor Armature Connections

Voltage follower

Instead of using a speed adjust potentiometer, the drive may be wired to follow an isolated (floating, or differential) 0–10 VDC signal that is isolated from earth ground (Figure 8). Connect the signal input (+) to S2. Connect the signal common (–) to S1. Make no connection to S3. A potentiometer can be used to scale the analog input voltage.

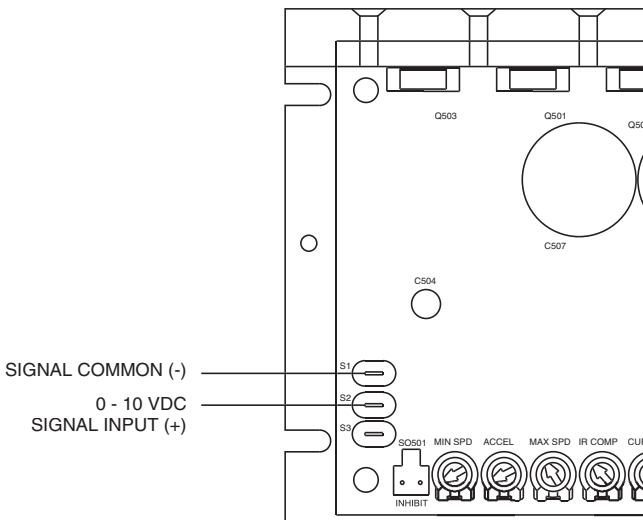

Figure 8. Voltage Follower Connections

Operation



Warning

Dangerous voltages exist on the drive when it is powered, and up to 30 seconds after power is removed and the motor stops. BE ALERT. High voltages can cause serious or fatal injury. For your safety, use personal protective equipment (PPE) when operating this drive.

Before applying power

- Verify that no conductive material is present on the printed circuit board.
- Ensure that all jumpers are properly set.

Startup and shutdown

To start the drive:

1. Turn the speed adjust potentiometer full counterclockwise (CCW), or set the voltage signal to zero.
2. Apply DC voltage input.
3. Slowly advance the speed adjust potentiometer clockwise (CW), or increase the voltage signal. The motor slowly accelerates as the potentiometer is turned CW or the voltage signal is increased. Continue until the desired speed is reached.
4. Remove DC voltage input from the drive to coast the motor to a stop.

If the motor or drive does not perform as described, disconnect the DC voltage input immediately. Refer to the Troubleshooting section (page 33) for further assistance.

Starting and stopping methods



Warning!

Decelerating to minimum speed or coasting to a stop is recommended for frequent starts and stops. Do not use any of these methods for emergency stopping. They may not stop a drive that is malfunctioning. Removing DC line power is the only acceptable method for emergency stopping.

For this reason, **Minarik strongly recommends installing an emergency stop switch** (see figure 7, page 13).

Frequent decelerating to minimum speed produces high torque. This may cause damage to motors, especially gearmotors that are not properly sized for the application.

Automatic restart upon power restoration

All drives automatically run to set speed when power is applied.

Line starting and line stopping

Line starting and line stopping (applying and removing DC voltage input) is recommended for infrequent starting and stopping of a drive only. When DC voltage input is applied to the drive, the motor accelerates to the speed set by the speed adjust potentiometer. When DC voltage input is removed, the motor coasts to a stop.

Decelerating to minimum speed

A single pole, single throw switch may be used to decelerate a motor to minimum speed (see Figure 9). Close the switch between S1 and S2 to decelerate the motor from set speed to minimum speed. Open the switch to accelerate the motor from minimum speed to set speed. The ACCEL trimpot setting determines the rate at which the motor accelerates.

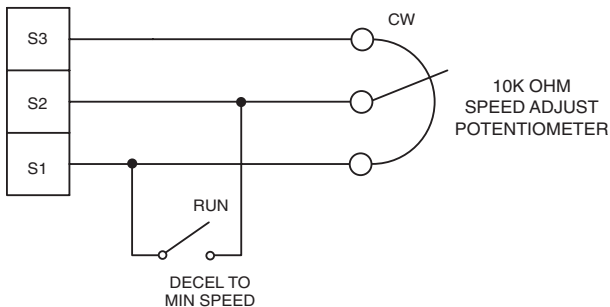

Figure 9. Run/Decelerate to Minimum Speed Switch

Inhibit terminals

Short the INHIBIT terminals to coast the motor to zero speed (see Figure 10 for INHIBIT terminal location). Reopen the INHIBIT terminals to accelerate the motor to set speed.

Twist inhibit wires and separate them from other power-carrying wires or sources of electrical noise. Use shielded cable if the inhibit wires are longer than 18 inches (46 cm). If shielded cable is used, ground only one end of the shield to earth ground. Do not ground both ends of the shield. See Shielding Guidelines, page 6.

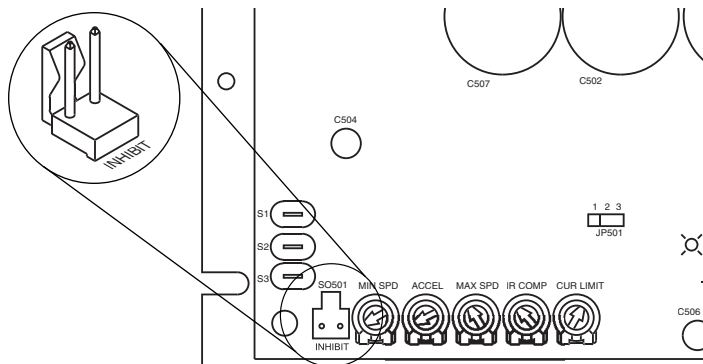

Figure 10. Inhibit Terminals

Power LED (IL501)

The power LED (IL501) lights whenever DC line voltage is applied to the drive. See Figure 11 below for the power LED location.

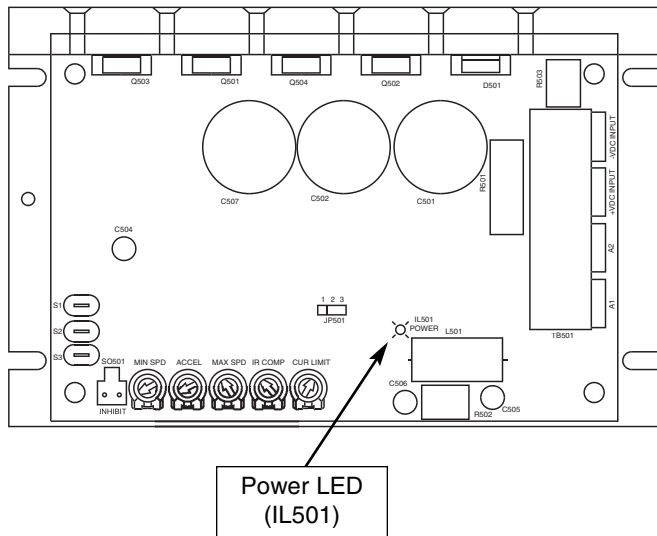

Figure 11. Power LED

Calibration



Warning

Dangerous voltages exist on the drive when it is powered, and up to 30 seconds after power is removed and the motor stops. When possible, disconnect the voltage input from the drive before adjusting the trimpots. If the trimpots must be adjusted with power applied, use insulated tools and the appropriate personal protection equipment. BE ALERT. High voltages can cause serious or fatal injury.

Each drive is factory calibrated to its maximum armature voltage and current rating. Readjust the calibration trimpot settings to accommodate a motor with a lower armature voltage and current rating.

All adjustments increase with clockwise rotation (CW), and decrease with counter-clockwise rotation (CCW). Use a non-metallic screwdriver for calibration. Each trimpot is identified on the printed circuit board (see Figure 12).

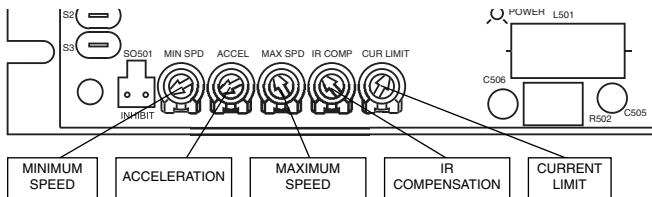

Figure 12. Calibration Trimpot Layout

MINIMUM SPEED (MIN SPD)

The MIN SPD setting determines the motor speed when the speed adjust potentiometer is turned full CCW. It is factory set for zero speed.

To calibrate MIN SPD:

1. Set the MAX SPD trimpot to full CW.
2. Set the MIN SPD trimpot to full CCW.
3. Turn the main speed adjust potentiometer to full CCW. If an input voltage is used instead of a speed adjust potentiometer, set the input signal to minimum.
4. Adjust the MIN SPD trimpot until the desired minimum motor speed is reached.

MAXIMUM SPEED (MAX SPD)

The MAX SPD setting determines the motor speed when the speed adjust potentiometer is turned full CW. It is factory set for maximum rated speed.

To calibrate MAX SPD:

1. Set the MAX SPD trimpot full CCW.
2. Apply power to the drive and turn the speed adjust potentiometer full CW. If an input voltage signal is used instead of a speed adjust pot, set the input signal to maximum.
3. Adjust the MAX SPD trimpot until the desired maximum motor speed is reached.

ACCELERATION (ACCEL)

The ACCEL setting determines the time the motor takes to accelerate to a higher speed. See **Specifications** on page 1 for approximate acceleration times. The ACCEL setting is factory set to its minimum value (full CCW).

To calibrate ACCEL:

1. Set the ACCEL trimpot full CCW.
2. Apply power to the drive and turn the main speed adjust potentiometer full CW. If an input voltage signal is used instead of a speed adjust pot, set the input signal to maximum. Note the time that the drive takes to accelerate to the desired speed.
3. Adjust the ACCEL trimpot until the desired acceleration time is reached. Turn the ACCEL trimpot CW to increase the acceleration time, and CCW to decrease the acceleration time.

IR COMPENSATION (IR COMP)

The IR COMP setting determines the degree to which motor speed is held constant as the motor load changes. It is factory set for optimum motor regulation.

Use the following procedure to recalibrate the IR COMP setting :

1. Set the IR COMP trimpot to minimum (full CCW).
2. Rotate the speed adjust potentiometer until the motor runs at midspeed without load (for example, 900 RPM for an 1800 RPM motor). A hand held tachometer may be used to measure motor speed.
3. Load the motor armature to its full load armature current rating. The motor should slow down.
4. While keeping the load on the motor, rotate the IR COMP trimpot until the motor runs at the speed measured in step 2. If the motor oscillates (overcompensation), the IR COMP trimpot may be set too high (CW). Turn the IR COMP trimpot CCW to stabilize the motor.
5. Unload the motor.

CURRENT LIMIT (CUR LIMIT)



Warning

CURRENT LIMIT should be set to 120% of motor nameplate current rating. Continuous operation beyond this setting may damage the motor. If you intend to operate beyond the rating, contact your Minarik representative.

The CURRENT LIMIT setting determines the maximum armature current output of the drive.

Recalibrate the CUR LIMIT setting when a lower current limit is required. Refer to the CUR LIMIT settings in Figure 13, page 26, or recalibrate using the following procedure:

1. With the power disconnected from the control, connect a DC ammeter in series with the armature.
2. Set the CUR LIMIT trimpot to minimum (full CCW).
3. Set the speed adjust potentiometer to maximum (full CW).
4. Carefully lock the motor armature. Be sure that the motor is firmly mounted.
5. Apply line power. The motor should be stopped.
6. Slowly adjust the CUR LIMIT trimpot CW slowly until the armature current is 120% of motor rated armature current.
7. Set the speed adjust potentiometer, or input voltage to minimum.
8. Remove the power from the drive and unlock the motor shaft.
9. Remove the ammeter in series with the motor armature if it is no longer needed and re-apply power to the drive.

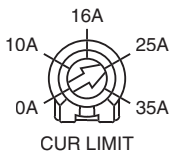
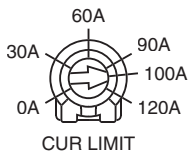
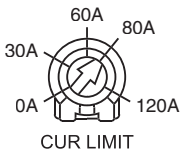
DC16-12/24**DC60-12/24****DC60-36/48****Figure 13. Approximate CUR LIMIT Settings**

Application Notes

Multiple fixed speeds

Replace the speed adjust potentiometer with series resistors with a total series resistance of 10K ohms (Figure 14). Add a single pole, multi-position switch with the correct number of positions for the desired number of fixed speeds.

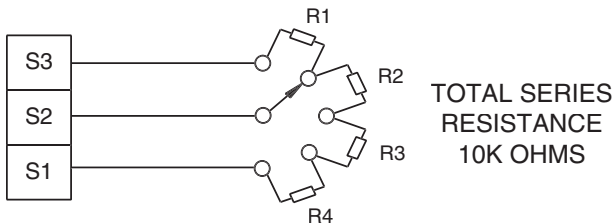

Figure 14. Multiple Fixed Speeds

Adjustable speeds using potentiometers in series

Replace the speed adjust potentiometer with a single pole, multi-position switch, and two or more potentiometers in series, with a total series resistance of 10K ohms. Figure 15 shows a connection for fixed high and low speed adjust potentiometers.

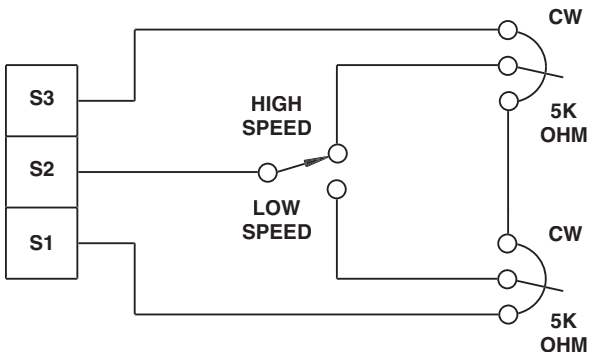

Figure 15. Adjustable Fixed Speeds Using Potentiometers in Series

Independent adjustable speeds

Replace the speed adjust potentiometer with a single pole, multi-position switch, and two or more potentiometers in parallel, with a total parallel resistance of 10K ohms. Figure 16 shows the connection of two independent speed adjust potentiometers that can be mounted at two separate operating stations.

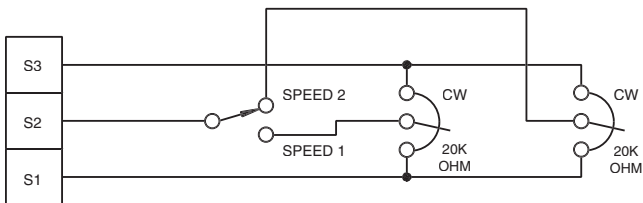

Figure 16. Independent Adjustable Speeds

RUN/JOG switch

Using a RUN/JOG switch is recommended in applications where quick stopping is not needed and frequent jogging is required. Use a single pole, two position switch for the RUN/JOG switch, and a normally closed, momentary operated pushbutton for the JOG pushbutton (see Figure 17). When the RUN/JOG switch is set to JOG, the motor decelerates to minimum speed. Press the JOG pushbutton to jog the motor. Return the RUN/JOG switch to RUN for normal operation.

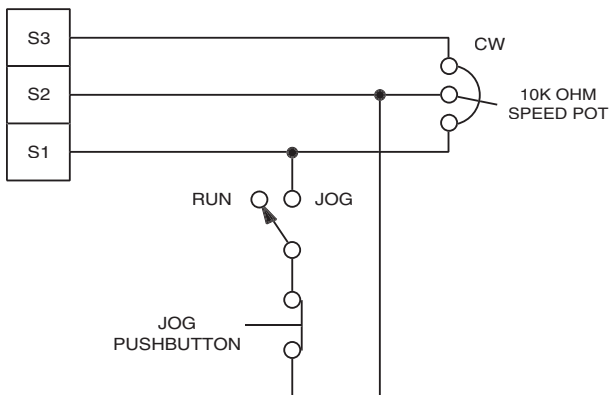

Figure 17. RUN/JOG Switch Connection to Speed Adjust Potentiometer

Reversing



Warning

Do not operate the control outside the recommended input $\pm 10\%$.

Relays may be used in place of a switch, but a neutral position must be provided to prevent plug reversing (see Figure 18, page 32). **DO NOT CHANGE DIRECTIONS WHILE THE MOTOR IS STILL RUNNING.** Plug reversing the motor (not allowing the motor to come to a stop before reversing) will cause excessively high currents to flow in the armature circuit, which can damage the control and/or motor and is not recommended.

CAUTION
 Motor and battery wire must be a minimum
 of 12 ga. and a maximum of 6 ga.

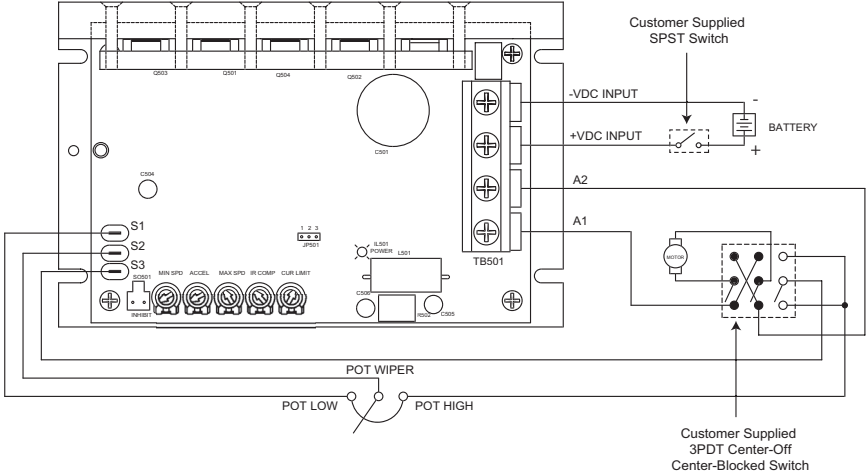

Figure 18. Reversing hookup diagram

Troubleshooting



Warning

Dangerous voltages exist on the drive when it is powered, and up to 30 seconds after power is removed and the motor stops. When possible, disconnect the drive while troubleshooting. High voltages can cause serious or fatal injury.

Before troubleshooting

Perform the following steps before starting any procedure in this section:

1. Disconnect DC voltage input from the drive.
2. Check the drive closely for damaged components.
3. Check that no conductive or other foreign material has become lodged on the printed circuit board.
4. Verify that all connections are correct and in good condition.
5. Verify that there are no short circuits or grounded connections.
6. Check that the drive's rated armature voltage and current is consistent with the motor ratings.

For additional assistance, contact your local Minarik distributor, or the factory direct:

Phone: (800) MINARIK or (800) 646-2745

Fax: (800) 394-6334

Symptom	Possible Causes	Suggested Solutions
Line fuse blows	<ol style="list-style-type: none"> 1. Line fuses are the wrong size. 2. Motor cable or armature is shorted to ground. 3. Nuisance tripping caused by a combination of ambient conditions and high-current spikes. 	<ol style="list-style-type: none"> 1. Check that line fuses are the correct size. 2. Check motor cable and armature for shorts. 3. Add a blower to cool the drive components; decrease CUR LIMIT settings, or resize motor and drive for actual load demand, or check for incorrectly aligned mechanical components for “jams”. See page 25 for information on adjusting the CUR LIMIT trimpot.
Line fuse does not blow, but the motor does not run	<ol style="list-style-type: none"> 1. Speed adjust pot or reference voltage is set to zero speed. 2. Speed adjust pot or reference voltage connections are open. 3. Drive is overloaded. 4. Drive is not receiving DC line voltage. 	<ol style="list-style-type: none"> 1. Increase speed adjust pot or reference voltage setting. 2. Check that the speed adjust pot or reference voltage connections are not open. 3. Verify that the motor is not jammed. Increase CURR LIMIT setting. 4. Apply DC line voltage to +VDC and -VDC.

Symptom	Possible Causes	Suggested Solutions
Line fuse does not blow, but the motor does not run (cont.)	5. Motor is not connected.	5. Connect motor to A1 and A2.
Motor runs too fast at maximum speed setting	1. MIN SPD and MAX SPD settings are too high.	1. Recalibrate MIN SPD and MAX SPD.
Motor runs too slow or too fast	1. MIN SPD and MAX SPD are not calibrated.	1. Recalibrate MIN SPD and MAX SPD
Motor will not reach the desired speed.	1. MAX SPD setting is too low. 2. IR COMP setting is too low. 3. Motor is overloaded.	1. Increase MAX SPD setting. 2. Increase IR COMP setting. 3. Check motor load. Resize the motor and drive if necessary.
Motor pulsates or surges under load.	1. IR COMP is set too high. 2. Control is in current limit mode.	1. Adjust the IR COMP setting slightly CCW until the motor speed stabilizes. 2. Check that motor and drive are of sufficient horsepower and amperage.

Notes

Unconditional Warranty

A. Warranty - Minarik Corporation (referred to as “the Corporation”) warrants that its products will be free from defects in workmanship and material for twelve (12) months or 3,000 hours, whichever comes first, from date of manufacture thereof. Within this warranty period, the Corporation will repair or replace, at its sole discretion, such products that are returned to Minarik Corporation, 901 East Thompson Avenue, Glendale, CA 91201-2011 USA.

This warranty applies only to standard catalog products, and does not apply to specials. Any returns for special controls will be evaluated on a case-by-case basis. The Corporation is not responsible for removal, installation, or any other incidental expenses incurred in shipping the product to and from the repair point.

B. Disclaimer - The provisions of Paragraph A are the Corporation's sole obligation and exclude all other warranties of merchantability for use, express or implied. The Corporation further disclaims any responsibility whatsoever to the customer or to any other person for injury to the person or damage or loss of property of value caused by any product that has been subject to misuse, negligence, or accident, or misapplied or modified by unauthorized persons or improperly installed.

C. Limitations of Liability - In the event of any claim for breach of any of the Corporation's obligations, whether express or implied, and particularly of any other claim or breach of warranty contained in Paragraph A, or of any other warranties, express or implied, or claim of liability that might, despite Paragraph B, be decided against the Corporation by lawful authority, the Corporation shall under no circumstances be liable for any consequential damages, losses, or expense arising in connection with the use of, or inability to use, the Corporation's product for any purpose whatsoever.

An adjustment made under warranty does not void the warranty, nor does it imply an extension of the original 12-month warranty period. Products serviced and/or parts replaced on a no-charge basis during the warranty period carry the unexpired portion of the original warranty only.

If for any reason any of the foregoing provisions shall be ineffective, the Corporation's liability for damages arising out of its manufacture or sale of equipment, or use thereof, whether such liability is based on warranty, contract, negligence, strict liability in tort, or otherwise, shall not in any event exceed the full purchase price of such equipment.

Any action against the Corporation based upon any liability or obligation arising hereunder or under any law applicable to the sale of equipment or the use thereof, must be commenced within one year after the cause of such action arises.



901 East Thompson Avenue
Glendale, California 91201-2011
Phone: (800) MINARIK or (800) 646-2745
Fax: (800) 394-6334

Document Number 250-0338, Revision 0
Printed in the U.S.A – 03/02