

BOSS-CM Quick Start Guide

General Information

This Quick Start Guide is intended for use by customers who have experience with Minarik's BOSS-series drives. Refer to User Manual 250-0280, BOSS Series Drives, for detailed installation, operation and troubleshooting information.

This Guide further assumes that the user has installed the BOSS-CM per User Manual 250-0280. This installation must be completed before connecting and operating the BOSS-CM.

Connections

ENABLE/DISABLE switch

Connect an ENABLE/DISABLE switch to terminals 1 and 2 as shown. Close the switch to accelerate to set speed. Open the switch to coast to a stop. If no switch is installed, jumper terminals 1 and 2 using AWG20 wire.

DIRECTION switch

Connect a DIRECTION switch to terminals 1 and 4 as shown. Open or close the switch as necessary to change direction.

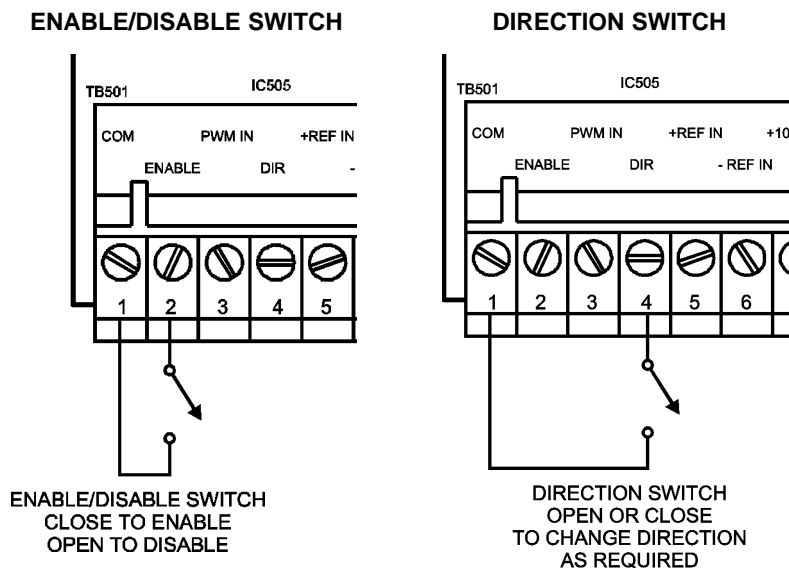

Signal input connections

NOTE: Do not connect PWM and analog voltage inputs simultaneously.

Connect a PWM input to terminals 1 and 3 as shown, OR an analog voltage signal input to terminals 1, 5 and 6 as shown. Because the BOSS-CM uses isolated inputs, the analog voltage signal may be grounded or floating. If an analog signal input is used, terminals 1 and 6 must be jumpered together to help reduce noise.

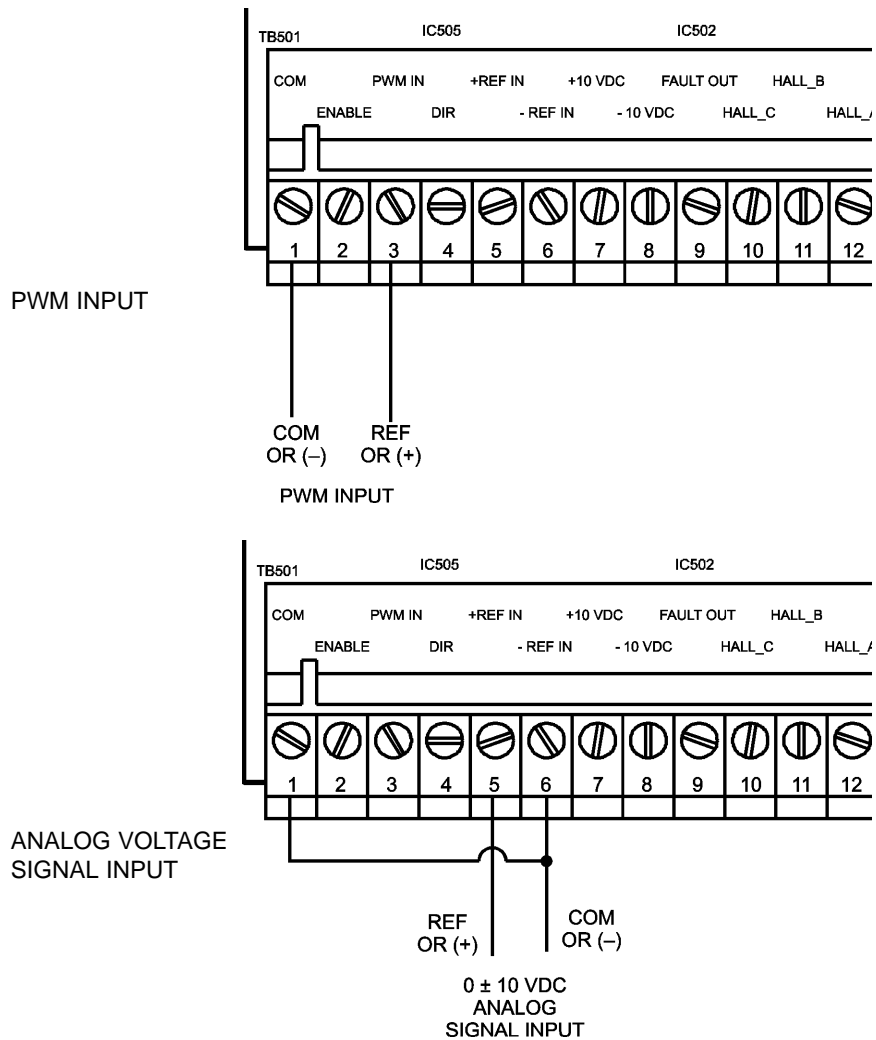

External sensor connections

Connect an external Hall sensor to terminals 10-12 as shown. If the sensor draws less than 20 mA @ 5V, connect sensor power leads to terminal 13 (COM) and terminal 14 (+5 VDC) as shown. If the sensor draws more than 20 mA @ 5V, an external, isolated power supply must be used.

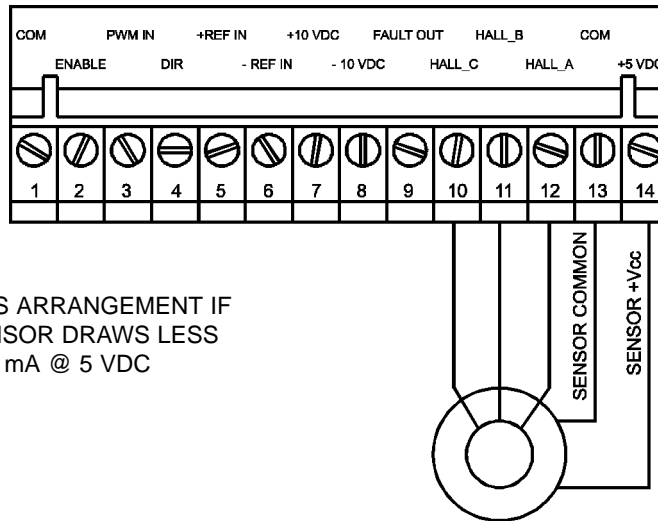

USE THIS ARRANGEMENT IF THE SENSOR DRAWS LESS THAN 20 mA @ 5V

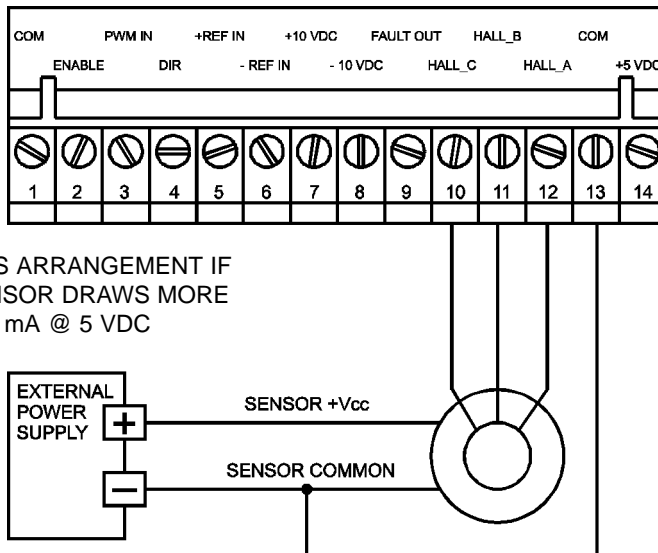

USE THIS ARRANGEMENT IF THE SENSOR DRAWS MORE THAN 20 mA @ 5V

Operation

The BOSS-CM provides a current output proportional to the input signal, up to the threshold set by the CURRENT LIMIT trimpot. If the input voltage range is 0-10 VDC, the BOSS-CM current output will be zero with 0 VDC input. The BOSS-CM current output will be maximum drive current with a 10 VDC input, if the CURRENT LIMIT trimpot is set to exceed maximum drive current.

Before applying power

- Verify that line voltage to the drive has been disconnected.
- Verify that hall sensor spacing jumper J501 and PWM/VDC input jumper J502 are set to the proper positions for your application. Refer to BOSS Series User Manual 250-0280 for more information.
- Verify that the ENABLE/DISABLE switch is set to the STOP (open) position.
- Verify that you have connected EITHER TB501 terminal 3 (for PWM input) OR terminal 5 (for analog signal input). The drive will not accept signals from both.

Startup and Shutdown

1. Set the input signal (PWM or analog voltage signal) to minimum.
2. With the ENABLE/DISABLE switch set to the STOP (open) position, apply line voltage.
3. Set the ENABLE/DISABLE switch to the RUN (closed) position.
4. Slowly increase the input PWM or analog voltage signal to the desired setting. The motor will slowly accelerate to the desired speed.

To change direction

Open or close the DIR switch as required to change direction.

Drive shutdown

Set the RUN/STOP switch to STOP (open) or remove line voltage. The motor will coast to a stop. The motor will accelerate to set speed when line voltage is applied or when the RUN/STOP switch is set to RUN (closed).

