

USER'S MANUAL

LVBL Series

Single-Quadrant
Adjustable Speed Drives
for DC Brushless Motors

Models:

LVBL02-24AC/DC
LVBL06-24AC/DC



Copyright © 2001 by
Minarik Corporation

All rights reserved. No part of this manual may be reproduced or transmitted in any form without written permission from Minarik Corporation. The information and technical data in this manual are subject to change without notice. Minarik Corporation and its Divisions make no warranty of any kind with respect to this material, including, but not limited to, the implied warranties of its merchantability and fitness for a given purpose. Minarik Corporation and its Divisions assume no responsibility for any errors that may appear in this manual and make no commitment to update or to keep current the information in this manual.

Printed in the United States of America.

Safety Warnings



- This symbol  denotes an important safety tip or warning. **Please read these instructions carefully** before performing any of the procedures contained in this manual.
- **DO NOT INSTALL, REMOVE, OR REWIRE THIS EQUIPMENT WITH POWER APPLIED.** Have a qualified electrical technician install, adjust and service this equipment. Follow the National Electrical Code and all other applicable electrical and safety codes, including the provisions of the Occupational Safety and Health Act (OSHA), when installing equipment.
- Reduce the chance of an electrical fire, shock, or explosion by proper grounding, over-current protection, thermal protection, and enclosure. Follow sound maintenance procedures.



It is possible for a drive to run at full speed as a result of a component failure. Minarik strongly recommends the installation of a master switch in the main power input to stop the drive in an emergency.

Circuit potentials are at 115 VAC or 230 VAC above earth ground. Avoid direct contact with the printed circuit board or with circuit elements to prevent the risk of serious injury or fatality. Use a non-metallic screwdriver for adjusting the calibration trimpots. Use approved personal protective equipment and insulated tools if working on this drive with power applied.

Table of Contents

Safety Warnings	i
Specifications	1
Dimensions	2
Installation	4
Drive mounting	4
Wiring	5
Heat sinking	7
Fusing	7
Speed adjust potentiometer mounting	8
Quick-connect terminal block	9
Optional transformer connections	14
Voltage follower	18
Motor Hall sensors	20
Operation	22
Startup	22
To reverse motor direction	23
Line starting and line stopping	23

Calibration	24
MINIMUM SPEED (MIN SPD)	26
MAXIMUM SPEED (MAX SPD)	26
CURRENT TRIP (LVBL06 only)	27
Application Notes	28
Multiple fixed speeds	28
Adjustable speeds using potentiometers in series	29
Independent adjustable speeds	30
RUN/JOG switch	31
Reversing (LVBL02)	32
Reversing (LVBL06)	33
Troubleshooting	34
Before troubleshooting	34
Diagnostic LEDs	35
Unconditional Warranty	inside back cover

Illustrations

Figure 1. LVBL02 Dimensions	2
Figure 2. LVBL06 Dimensions	3
Figure 3. Speed Adjust Potentiometer Mounting	8
Figure 4. Quick-Connect Terminal Plug	9
Figure 5. LVBL02 Power and Signal Connections	10
Figure 6. LVBL06 Power Connections	11
Figure 7. LVBL06 Motor Connections	12
Figure 8. LVBL06 Signal Connections	13
Figure 9. 115 VAC Transformer Connection to LVBL02	14
Figure 10. 230 VAC Transformer Connection to LVBL02	15
Figure 11. 115 VAC Transformer Connection to LVBL06	16
Figure 12. 230 VAC Transformer Connection to LVBL06	17
Figure 13. LVBL02 Voltage Follower Connections	18
Figure 14. LVBL06 Voltage Follower Connections	19
Figure 15. LVBL02 Hall Sensor Selector Switch Location	20
Figure 16. LVBL06 Hall Sensor Selector Switch Location	21
Figure 17. LVBL02 Calibration Trimpot Layout	25
Figure 18. LVBL06 Calibration Trimpot Layout	25
Figure 19. Multiple Fixed Speeds	28
Figure 20. Adjustable Speeds Using Potentiometers in Series	29
Figure 21. Independent Adjustable Speeds	30
Figure 22. RUN/JOG Switch	31
Figure 23. LVBL02 Reversing Circuit Connection	32
Figure 24. LVBL06 Reversing Circuit Connection	33
Figure 25. LVBL02 LED Locations	36
Figure 26. LVBL06 LED Locations	36

Specifications

Model	Maximum Continuous Armature Current (DC Amps)	Maximum Peak Armature Current (DC Amps)
LVBL02-24AC/DC	2	3*
LVBL06-24AC/DC	6	9*

* Peak current applied for less than 1 second. See pg 26 for details.

AC Voltage Input Range	24 – 36 VAC, $\pm 10\%$, 50–60 Hz
DC Voltage Input Range	24 – 48 VDC, $\pm 10\%$
Speed Regulation (typical)	3% of base speed
Speed Range	60:1
Speed Adjust Potentiometer	10K Ω
Analog Input Voltage Range (isolated)	0 – 2 VDC
Input Impedance	60K Ω
Weight	
LVBL02-24AC/DC	2 lb
LVBL06-24AC/DC	3 lb
Ambient Operating Temperature Range	0 – 40° C
Vibration	0.5g max (0 – 50 Hz) 0.1g max (above 50 Hz)

Dimensions

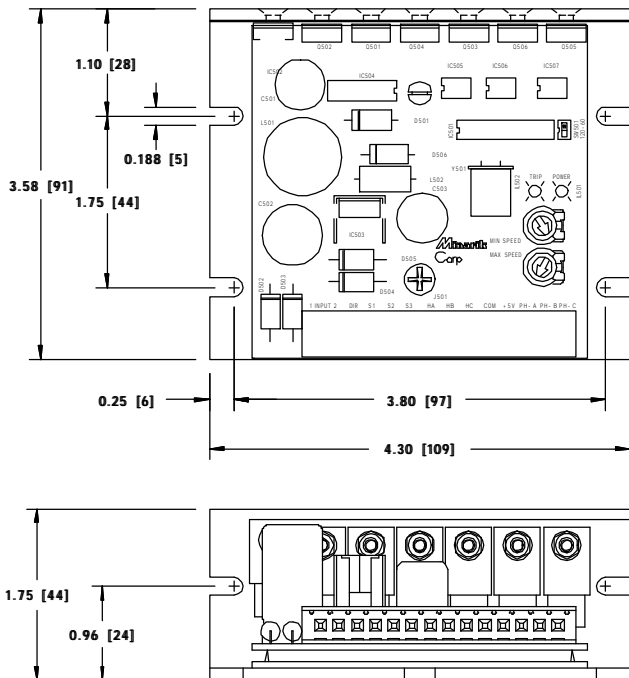

Figure 1. LVBL02 Dimensions

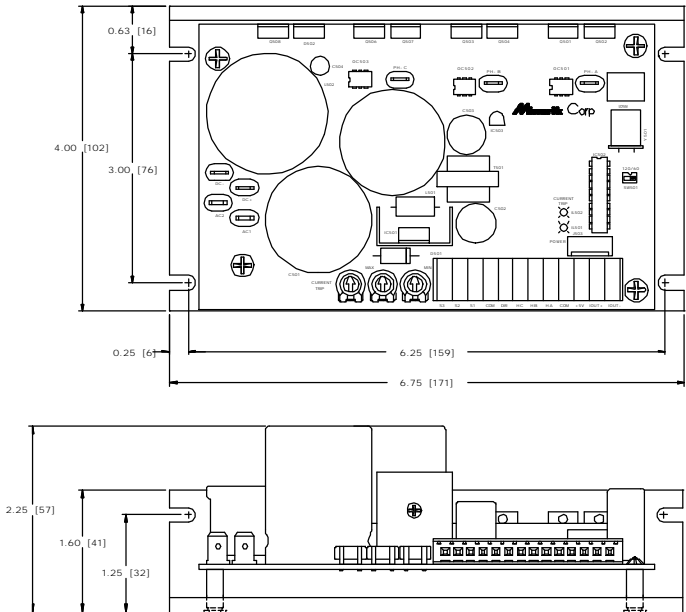

Figure 2. LVBL06 Dimensions

Installation

Drive mounting

- Drive components are sensitive to electrostatic fields. Avoid direct contact with the circuit board. Hold drive by the chassis only.
- Protect the drive from dirt, moisture, and accidental contact. Provide sufficient room for access to the terminal block and calibration trimpots.
- Mount the drive away from heat sources. Operate the drive within the specified ambient operating temperature range.
- Prevent loose connections by avoiding excessive vibration of the drive.
- Mount drive with its board in either a horizontal or vertical plane. Six 0.19 in. (5 mm) wide slots in the chassis accept #8 pan head screws. Fasten either the large base or the narrow flange of the chassis to the subplate.
- The chassis does not have to be earth grounded. If you choose to ground the chassis, use a star washer beneath the head of at least one of the mounting screws to penetrate the anodized chassis surface and to reach bare metal.

Wiring



Warning



Do not install, remove, or rewire this equipment with power applied. Failure to heed this warning may result in fire, explosion, or serious injury.

Circuit potentials are at 115 or 230 VAC above ground. To prevent the risk of injury or fatality, avoid direct contact with the printed circuit board or with circuit elements.

Do not disconnect any of the motor leads from the drive unless power is removed or the drive is disabled. Opening any one motor lead may destroy the drive.

- Use 18–20 AWG wire for speed adjust potentiometer and Hall sensor wiring. Use 16–18 AWG wire for AC line (L1, L2) and motor (phase A, B and C) wiring.

Shielding guidelines



Warning

Under no circumstances should power and logic leads be bundled together. Induced voltage can cause unpredictable behavior in any electronic device, including motor controls.

As a general rule, Minarik recommends shielding of all conductors.

If it is not practical to shield power conductors, Minarik recommends shielding all logic-level leads. If shielding of logic leads is not practical, the user should twist all logic leads with themselves to minimize induced noise.

It may be necessary to earth ground the shielded cable. If noise is produced by devices other than the drive, ground the shield at the drive end. If noise is generated by a device on the drive, ground the shield at the end away from the drive. Do not ground both ends of the shield.

If the drive continues to pick up noise after grounding the shield, it may be necessary to add AC line filtering devices, or to mount the drive in a less noisy environment.

Logic wires from other input devices, such as motion controllers and PLL velocity controllers, must be separated from power lines in the same manner as the logic I/O on this drive.

Heat sinking

LVBL series drives have sufficient heat sinking built into their basic configurations. No additional heat sinking is required.

Fusing



Warning

All Minarik drives should be protected by fuses. Use a fast acting fuse rated for approximately 200% of the motor current and at least 50 volts.

Speed adjust potentiometer mounting



Warning

Be sure that the potentiometer tabs do not make contact with the potentiometer enclosure. Grounding the input will cause damage to the drive.

Install the circular insulating disk between the panel and the 10K ohm speed adjust potentiometer. Mount the speed adjust potentiometer through a 0.38 inch (10 mm) hole with the hardware provided (Figure 3). Twist the speed adjust potentiometer wire to avoid picking up unwanted electrical noise. If potentiometer leads are longer than 18 inch (457 mm), use shielded cable.

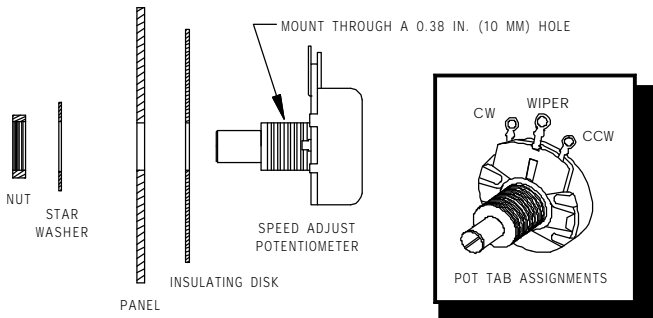

Figure 3. Speed Adjust Potentiometer Mounting

Quick-connect terminal block

The quick-connect terminal block is composed of a header block and terminal plug (Figure 4). To use the quick-connect terminal block:

1. Carefully pull terminal plug from header block.
2. With a small flat-head screwdriver, turn terminal plug screw counterclockwise to open wire clamp.
3. Insert stripped wire into the large opening in front of the plug.
4. Turn the terminal plug screw clockwise to clamp the wire.
5. Repeat steps 2–4 for each terminal until all connections are made.
6. Insert plug into header until securely fastened.

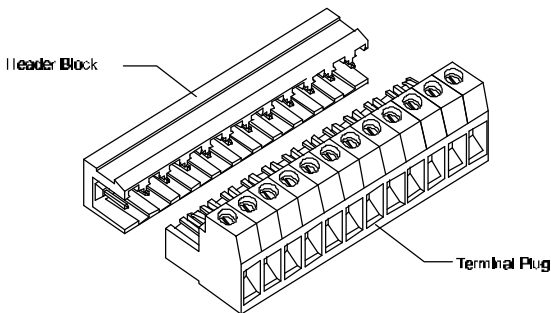

Figure 4. Quick-Connect Terminal Plug

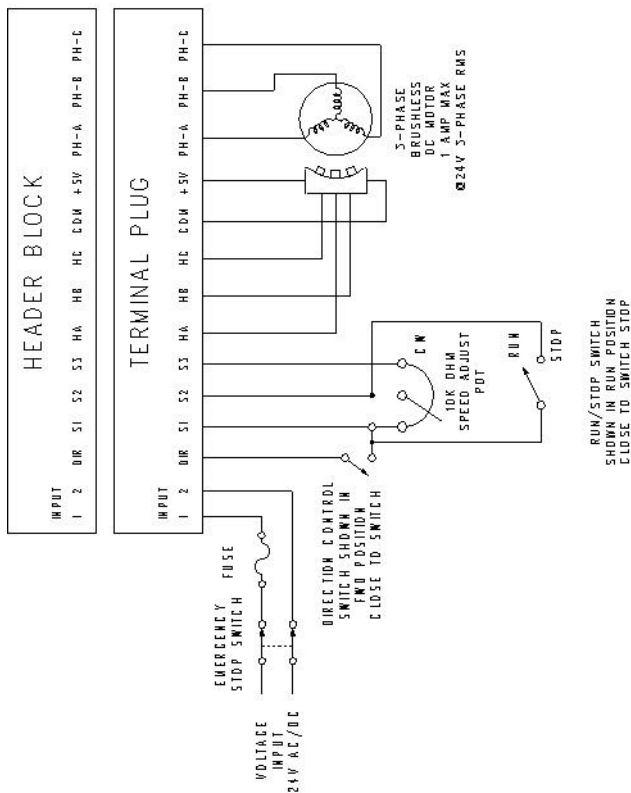

Figure 5. LVBL02 Power and Signal Connections

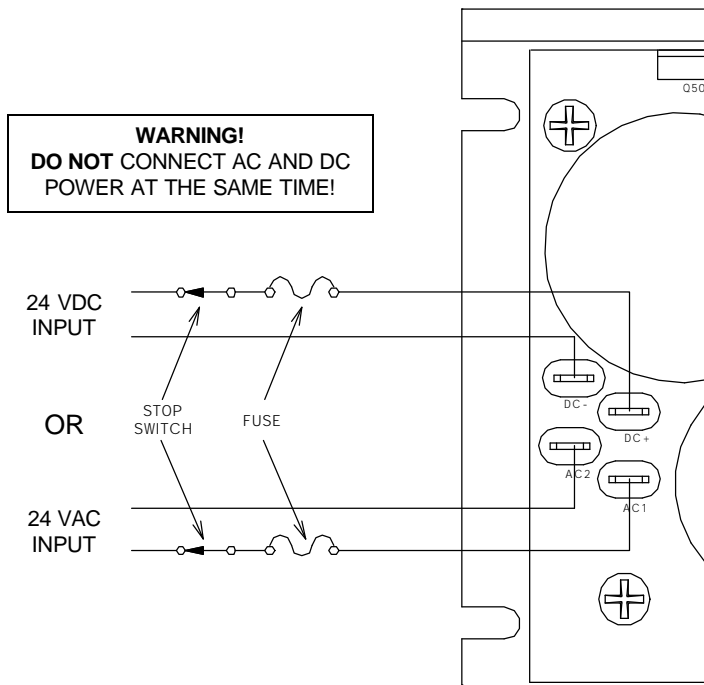

Figure 6. LVBL06 Power Connections

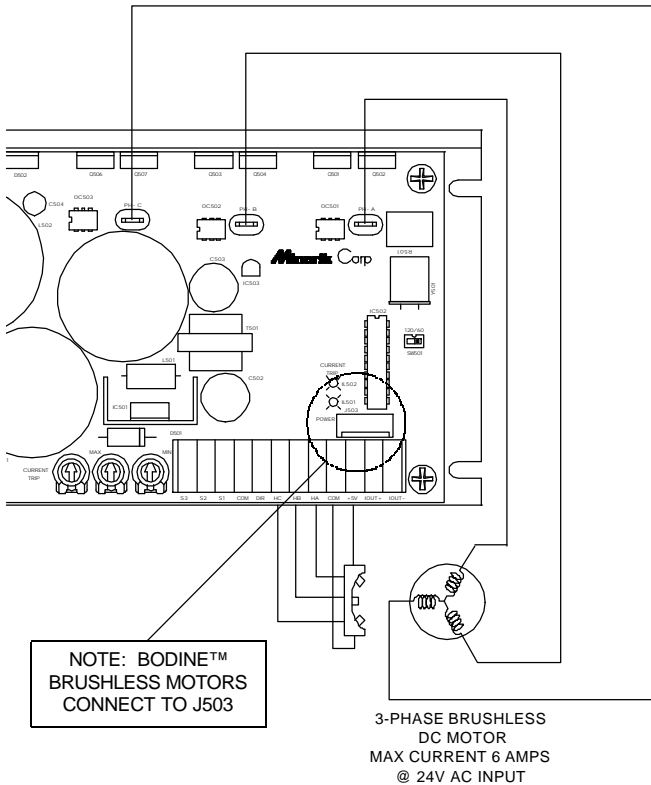

Figure 7. LVBL06 Motor Connections

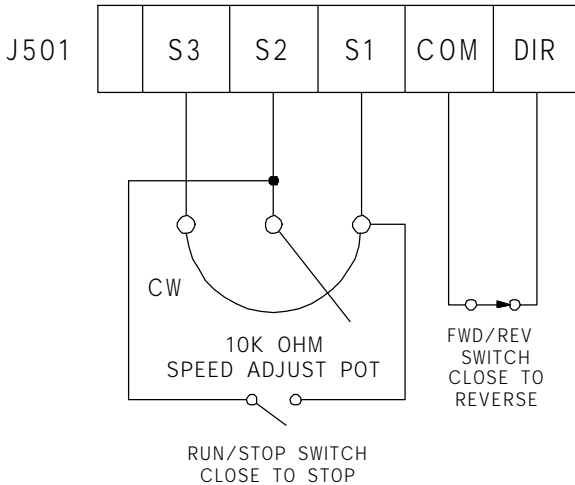

Figure 8. LVBL06 Signal Connections

Optional transformer connections

LVBL02

Connect a dual-primary transformer, Minarik p/n 230-0110, to the inputs of the LVBL drive. Figure 9 shows the connection of a 115 VAC source.



The transformer's secondary windings must be rated at a minimum of 200% of motor nameplate current.

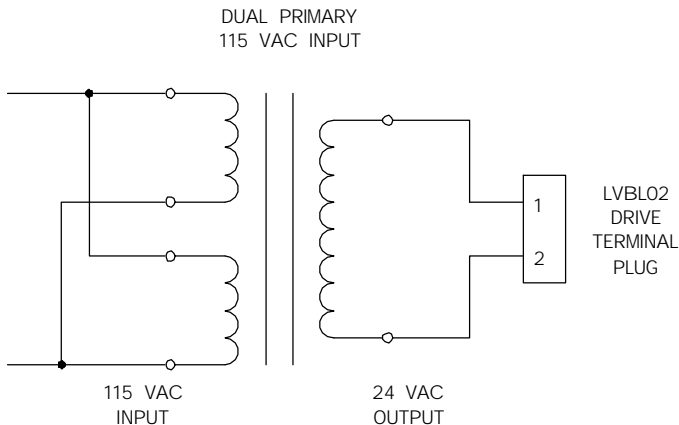

Figure 9. 115 VAC Transformer Connection to LVBL02

Connect a dual-primary transformer, Minarik p/n 230-0110, to the inputs of the LVBL drive. Figure 10 shows the connection of a 230 VAC source.



The transformer's secondary windings must be rated at a minimum of 200% of motor nameplate current.

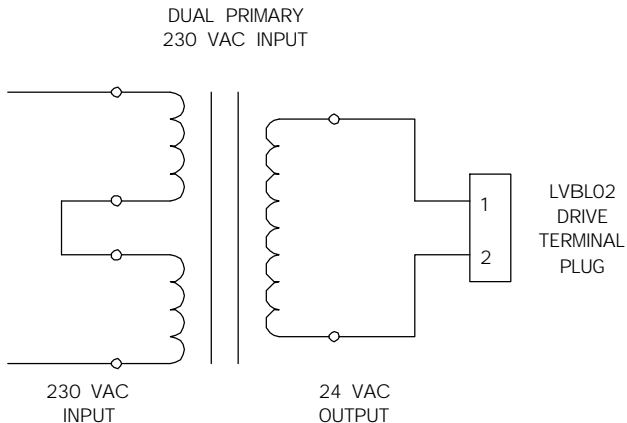

Figure 10. 230 VAC Transformer Connection to LVBL02

LVBL06

Connect a dual-primary transformer, Minarik p/n 230-0112, to the inputs of the LVBL drive. Figure 11 shows the connection of a 115 VAC source.



The transformer's secondary windings must be rated at a minimum of 200% of motor nameplate current.

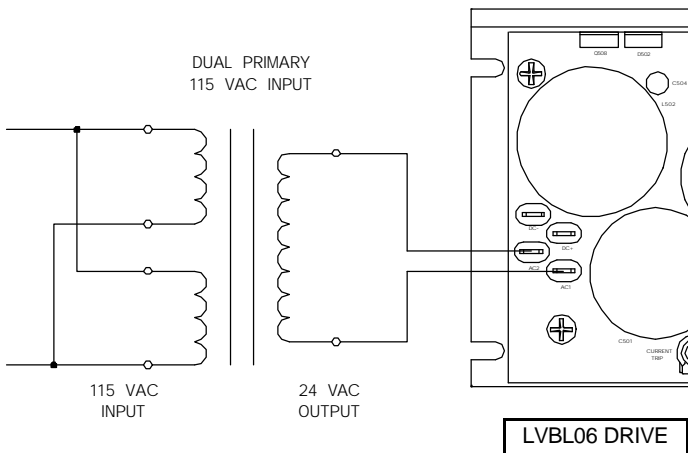

Figure 11. 115 VAC Transformer Connection to LVBL06

Connect a dual-primary transformer, Minarik p/n 230-0112, to the inputs of the LVBL drive. Figure 12 shows the connection of a 230 VAC source.



The transformer's secondary windings must be rated at a minimum of 200% of motor nameplate current.

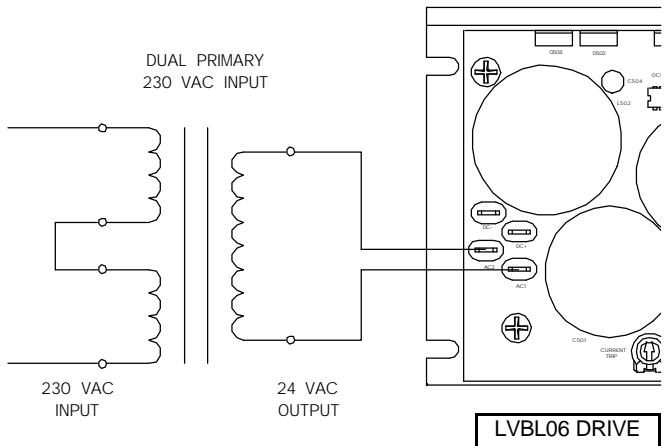

Figure 12. 230 VAC Transformer Connection to LVBL06

Voltage follower

Instead of using a speed adjust potentiometer, LVBL series drives may be wired to follow a floating voltage signal that is isolated from earth ground. Connect a 0 to +2 VDC signal to terminals S1 and S2 (see Figure 13 for LVBL02 voltage follower connections; see Figure 14 for LVBL06 voltage follower connections).

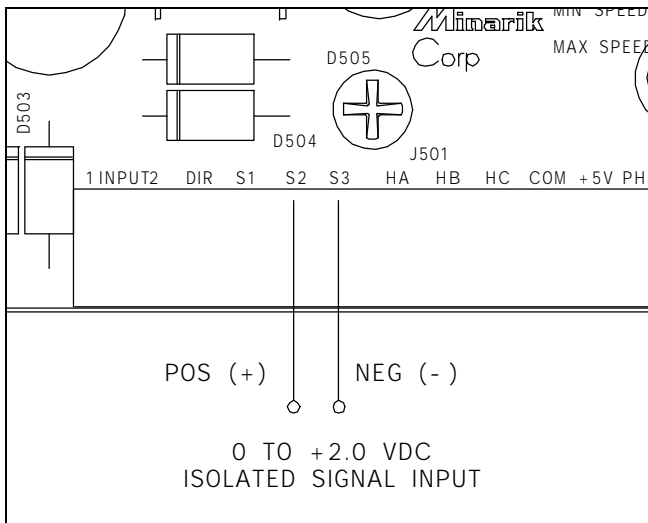

Figure 13. LVBL02 Voltage Follower Connections

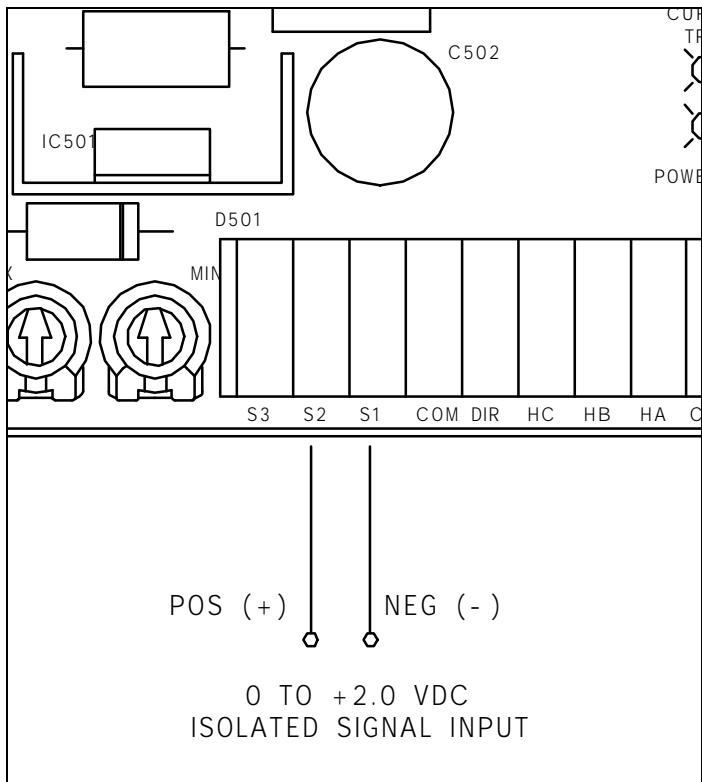

Figure 14. LVBL06 Voltage Follower Connections

Motor Hall sensors

LVBL series drives run brushless motors with nulled hall sensors (60° or 120° electrical spacing). Hall sensors are not allowed to be advanced or retarded. To reverse motor rotation, the LVBL drive switches the Hall sensor sequence, eliminating the need to switch motor leads. Set switch SW501 to 60° or 120°, depending on your motor. Contact the motor manufacturer for information on hall sensor spacing. See Figure 15 for LVBL02 switch locations and Figure 16, page 21 for LVBL06 switch locations.

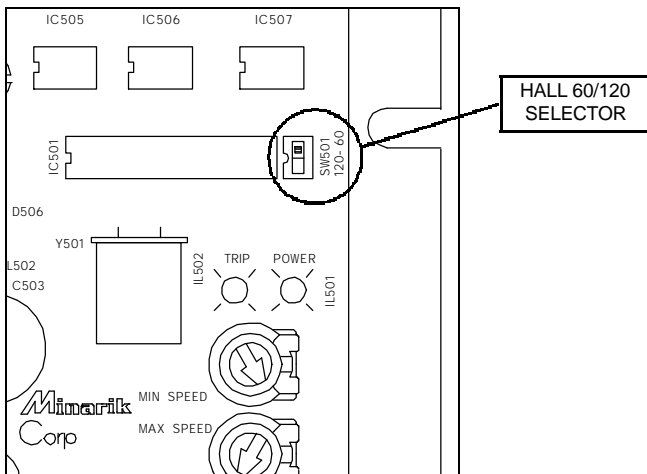

Figure 15. LVBL02 Hall Sensor Selector Switch Location

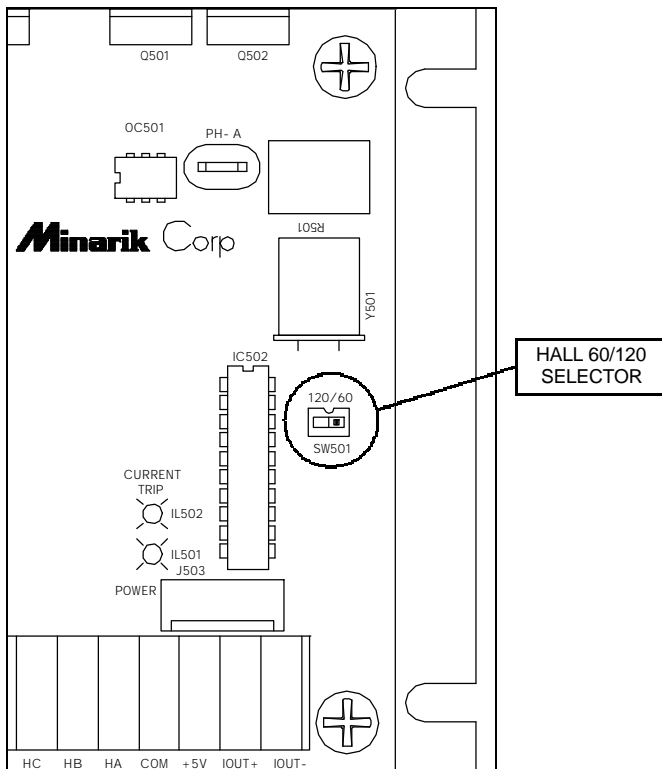

Figure 16. LVBL06 Hall Sensor Selector Switch Location

Operation



Do not change the position of Hall sensor switch SW501 after power has been applied. The drive's on-board microcontroller will disregard any changes in switch position after power is applied.

Startup

1. Verify that no conductive material is present on the PCB.
2. Set motor Hall sensor switch SW501 to 60° or 120°, depending on your motor.
3. Set the direction switch to the direction you want the motor to rotate on startup. If no direction switch is installed, insert or remove a jumper between the DIR and S1 terminals of terminal board TB501, as required. See “Reversing” in the *Application Notes* section for more information.
4. Apply AC or DC voltage input to the drive.
5. Slowly advance the speed adjust potentiometer clockwise (CW). If a voltage signal is used, slowly increase the voltage signal. Continue until the desired speed is reached.

To reverse motor direction

Set the direction switch to the opposite position. If no direction switch is installed, insert or remove a jumper between the DIR and S1 terminals of terminal board TB501, as required. See “Reversing” in the *Application Notes* section for more information.

Line starting and line stopping



Minarik strongly recommends the installation of an emergency stop switch. The switch contacts should be rated at a minimum of 48 volts and 200% of maximum motor current. See *Connections*, pages 10 - 11.

Line starting and line stopping (applying and removing AC or DC voltage input) is recommended for infrequent starting and stopping of the drive only. It is also the recommended method for emergency stopping of the drive. When AC or DC voltage input is applied to the drive, the motor accelerates to the speed set by the speed adjust potentiometer. When AC or DC voltage input is removed, the motor coasts to a stop.

Calibration



Warning

Dangerous voltages exist on the drive when it is powered. When possible, disconnect the voltage input from the drive before adjusting the trimpots. If the trimpots must be adjusted with power applied, use insulated tools and the appropriate personal protection equipment. **BE ALERT.** High voltages can cause serious or fatal injury.

Each drive is factory calibrated to its maximum current rating. Readjust the calibration trimpot settings to accommodate lower current rated motors. All adjustments increase with CW rotation, and decrease with CCW rotation. Use a non-metallic screwdriver for calibration. Each trimpot is identified on the printed circuit board. Refer to Figure 17 and 18, page 25 for LVBL trimpot locations.

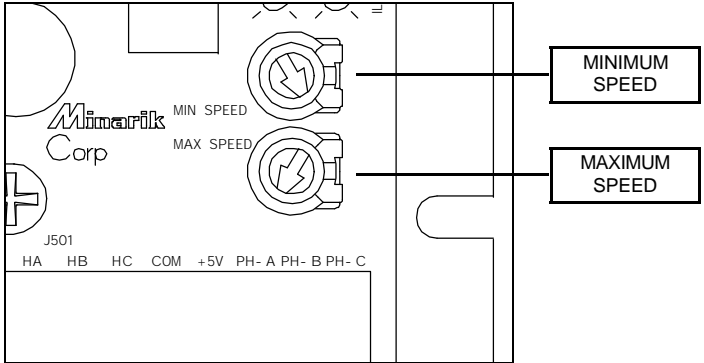

Figure 17. LVBL02 Calibration Trimpot Layout

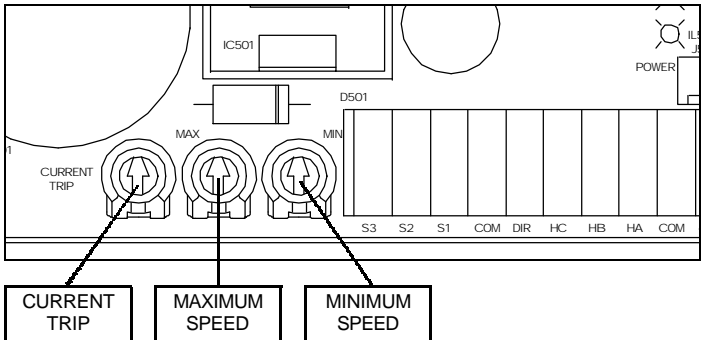

Figure 18. LVBL06 Calibration Trimpot Layout

MINIMUM SPEED (MIN SPD)

The MIN SPD setting determines the motor speed when the speed adjust potentiometer is turned full CCW. It is factory set to zero speed.

To calibrate, turn the speed adjust potentiometer full CCW. Apply power and rotate the MIN SPD trimpot CW until the motor is running at the desired minimum speed.

MAXIMUM SPEED (MAX SPD)

The MAX SPD setting determines the motor speed when the speed adjust potentiometer is turned full CW. It is factory set for maximum rated speed.

To calibrate, set the MAX SPD trimpot full CCW. Turn the speed adjust potentiometer full CW. Adjust the MAX SPD trimpot until the desired maximum motor speed is reached.

Note: Check the MIN SPD and MAX SPD adjustments after recalibrating to verify that the motor runs at the desired minimum and maximum speed.

CURRENT TRIP (LVBL06 only)

The CURRENT TRIP setting determines the maximum motor current output of the drive. If this setting is exceeded, the drive will go into current trip mode.

The LVBL06 drive incorporates an operational amplifier which converts the drive's load current to DC volts on a 1:1 scale, e.g., a 1 amp DC output is converted to 1 VDC. Recalibrate the CURRENT TRIP setting, as outlined below, when using a lower current rated motor.

To calibrate CURRENT TRIP:

1. With the power disconnected from the drive, connect a DC voltmeter (0–10 V minimum scale) to the LOUT+ and LOUT– terminals of connector J501. Observe proper polarity when connecting the voltmeter.
2. Set the CURRENT TRIP trimpot to maximum (full CW).
3. Connect power to the drive.
4. Load the motor to rated current and slowly rotate the CURRENT TRIP trimpot CCW until the CURRENT TRIP LED just lights. If the CURRENT TRIP LED starts to blink, the motor will shut down. To reset the drive, remove power for 30 seconds and restart.
5. Set the speed adjust potentiometer to minimum and remove power.

Application Notes

Multiple fixed speeds

Replace the speed adjust potentiometer with series resistors with a total series resistance of 10K ohms (Figure 19). Add a single pole, multi-position switch with the correct number of positions for the desired number of fixed speeds.

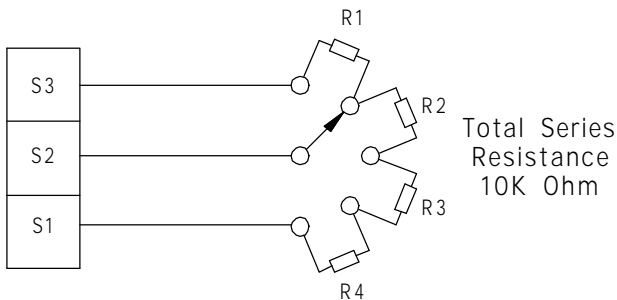

Figure 19. Multiple Fixed Speeds

Adjustable speeds using potentiometers in series

Replace the speed adjust potentiometer with a single pole, multi-position switch, and two or more potentiometers in series, with a total series resistance of 10K ohms. Figure 20 shows a connection for fixed high and low speed adjust potentiometers.

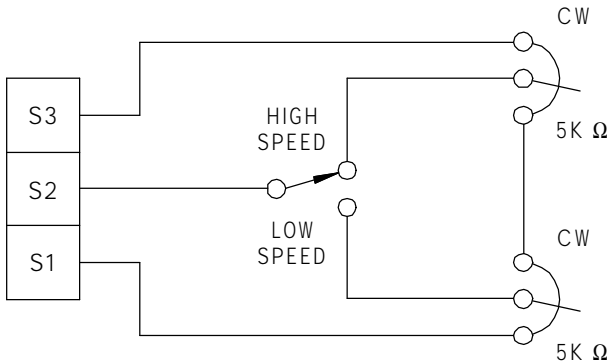

Figure 20. Adjustable Speeds Using Potentiometers in Series

Independent adjustable speeds

Replace the speed adjust potentiometer with a single pole, multi-position switch, and two or more potentiometers in parallel, with a total parallel resistance of 10K ohms. Figure 21 shows the connection of two independent speed adjust potentiometers that can be mounted at two separate operating stations.

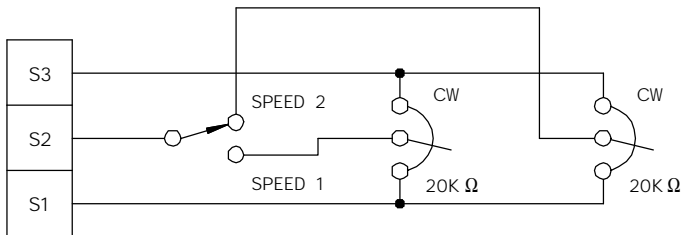

Figure 21. Independent Adjustable Speeds

RUN/JOG switch

Connect the RUN/JOG switch and the JOG pushbutton as shown in Figure 22. When the RUN/JOG switch is set to JOG, the motor decelerates to minimum speed (minimum speed is determined by the MIN SPD trimpot setting). Press the JOG pushbutton to jog the motor. Return the RUN/JOG switch to RUN for normal operation.

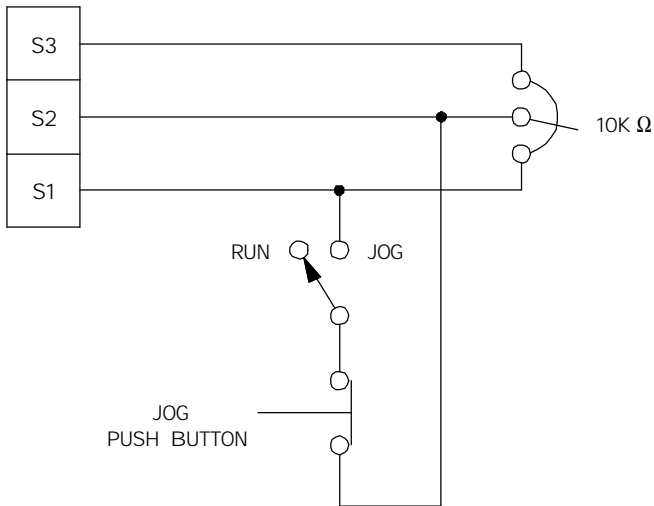

Figure 22. RUN/JOG Switch

Reversing (LVBL02)



Warning

Motor reverses very rapidly! To avoid damage to motors, set RUN/STOP switch to STOP and wait for the motor to come to a stop before reversing.

Use a single-pole, single-throw switch rated for 12 VDC @ 1 mA. Open the switch to rotate the motor shaft in the forward direction. Close the switch to reverse the motor shaft. See Figure 23, below.

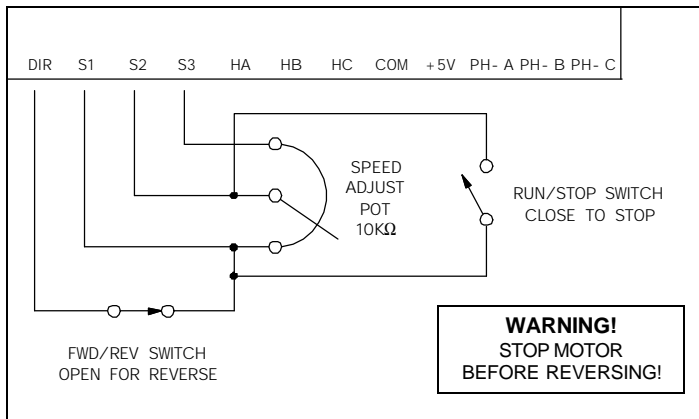

Figure 23. LVBL02 Reversing Circuit Connection

Reversing (LVBL06)



Warning

Motor reverses very rapidly! To avoid damage to motors, set RUN/STOP switch to STOP and wait for the motor to come to a stop before reversing.

Use a single-pole, single-throw switch rated for 12 VDC @ 1 mA (Figure 24). Open the switch to rotate the motor shaft in the forward direction. Close the switch to reverse the motor shaft.

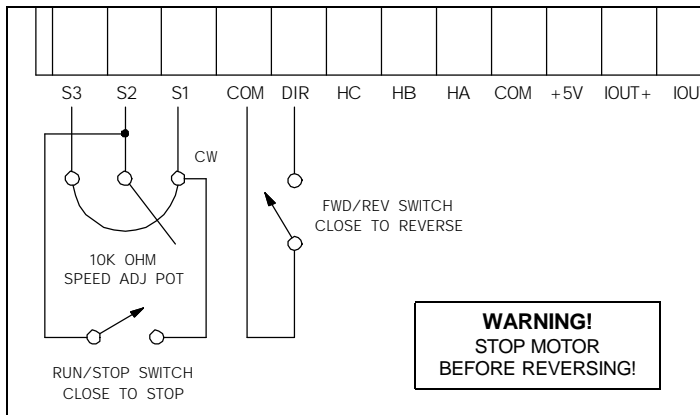

Figure 24. LVBL06 Reversing Circuit Connection

Troubleshooting

Before troubleshooting

Perform the following steps before starting any procedure in this section:

1. Disconnect AC or DC voltage input from the drive. Wait 30 seconds for power to discharge.
2. Check the drive closely for damaged components.
3. Check that no wire chips or other foreign material has become lodged on the printed circuit board.
4. Verify that every connection is correct and in good condition.
5. Verify that there are no short circuits or grounded connections.
6. Check that the drive's rated phase current and rms voltage are consistent with the motor ratings.

For additional assistance, contact your local Minarik® distributor, or the factory direct at: Phone: (800) MINARIK or Fax: (800) 394-6334.

Diagnostic LEDs

POWER ON (green)

The green POWER ON LED lights when power is applied to the drive. It will blink in proportion to motor speed, i.e., the faster the motor speed, the faster the LED blink rate. Refer to Figure 25 and 26 for POWER ON LED locations.

TRIP (red)

The red TRIP LED lights when the drive output reaches maximum current limit. If the drive is at maximum current for approximately 1 second, it will shut off the motor. To reset the trip circuit, turn power off for approximately 30 seconds, then restart. Refer to Figure 25 and 26 for TRIP LED locations.

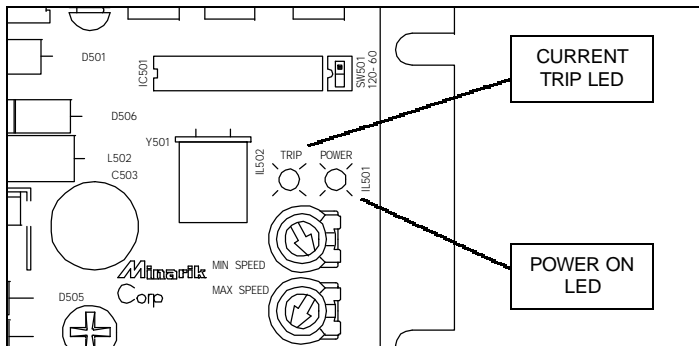

Figure 25. LVBL02 LED Locations

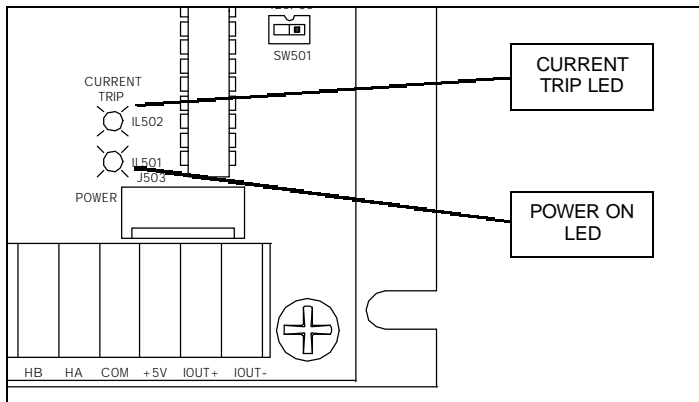

Figure 26. LVBL06 LED Locations

Problem	Possible Causes	Suggested Solutions
Line fuse blows.	<ol style="list-style-type: none">1. Line fuse is the wrong size.2. Motor cable is shorted to ground.3. Nuisance tripping caused by a combination of ambient conditions and high-current spikes (i.e. reversing).	<ol style="list-style-type: none">1. Check that the line fuse is correct for the motor size.2. Check motor cable for shorts.3. Add a blower to cool the drive components; decrease CURRENT TRIP (LVBL06 only) settings, or resize motor and drive for actual load demand, or check for incorrectly aligned mechanical components or “jams”.
Line fuse does not blow, but the motor does not run.	<ol style="list-style-type: none">1. Speed adjust pot or reference voltage is set to zero speed.2. Drive is in current limit.3. Drive is not receiving AC line voltage.4. Motor is not connected.	<ol style="list-style-type: none">1. Increase the speed adjust potentiometer setting or reference voltage.2. Verify that motor is not jammed. Increase CURRENT TRIP (LVBL06 only) setting if they are set too low.3. Apply AC line voltage to L1 and L2.4. Connect motor to A1 and A2.

Problem	Possible Causes	Suggested Solutions
Motor does not stop when the speed adjust potentiometer is full CCW.	MIN SPD setting is too high.	Calibrate MIN SPD.
Motor runs too fast.	MAX SPD and MIN SPD are set too high.	Calibrate MAX SPD and MIN SPD.
Motor will not reach the desired speed.	<ol style="list-style-type: none">1. MAX SPD setting is too low.2. CURRENT TRIP setting is too low.4. Motor is overloaded.	<ol style="list-style-type: none">1. Increase MAX SPD setting.2. Increase CURRENT TRIP setting. (LVBL06 only)4. Check motor load. Resize the motor and drive if necessary.

NOTES

NOTES

Unconditional Warranty

A. Warranty - Minarik Corporation (referred to as "the Corporation") warrants that its products will be free from defects in workmanship and material for twelve (12) months or 3,000 hours, whichever comes first, from date of manufacture thereof. Within this warranty period, the Corporation will repair or replace, at its sole discretion, such products that are returned to Minarik Corporation, 901 East Thompson Avenue, Glendale, CA 91201-2011 USA.

This warranty applies only to standard catalog products, and does not apply to specials. Any returns for special controls will be evaluated on a case-by-case basis. The Corporation is not responsible for removal, installation, or any other incidental expenses incurred in shipping the product to and from the repair point.

B. Disclaimer - The provisions of Paragraph A are the Corporation's sole obligation and exclude all other warranties of merchantability for use, express or implied. The Corporation further disclaims any responsibility whatsoever to the customer or to any other person for injury to the person or damage or loss of property of value caused by any product that has been subject to misuse, negligence, or accident, or misapplied or modified by unauthorized persons or improperly installed.

C. Limitations of Liability - In the event of any claim for breach of any of the Corporation's obligations, whether express or implied, and particularly of any other claim or breach of warranty contained in Paragraph A, or of any other warranties, express or implied, or claim of liability that might, despite Paragraph B, be decided against the Corporation by lawful authority, the Corporation shall under no circumstances be liable for any consequential damages, losses, or expense arising in connection with the use of, or inability to use, the Corporation's product for any purpose whatsoever.

An adjustment made under warranty does not void the warranty, nor does it imply an extension of the original 12-month warranty period. Products serviced and/or parts replaced on a no-charge basis during the warranty period carry the unexpired portion of the original warranty only.

If for any reason any of the foregoing provisions shall be ineffective, the Corporation's liability for damages arising out of its manufacture or sale of equipment, or use thereof, whether such liability is based on warranty, contract, negligence, strict liability in tort, or otherwise, shall not in any event exceed the full purchase price of such equipment.

Any action against the Corporation based upon any liability or obligation arising hereunder or under any law applicable to the sale of equipment or the use thereof, must be commenced within one year after the cause of such action arises.



901 E Thompson Avenue

Glendale, CA 91201-2011

Tel: (800) 646-2745

Fax: (800) 394-6334

<http://www.minarikcorp.com>

Document number 250-0261, Revision 3

Printed in the U.S.A – 4/01

\$11.00 U.S.A. – \$12.00 Canada