

USER'S MANUAL

Model VT7

**VISI-TACH® Multi-Functional
Digital Indicator**



Copyright © 1998 by
Minarik Corporation

All rights reserved. No part of this manual may be reproduced or transmitted in any form without written permission from Minarik Corporation. The information and technical data in this manual are subject to change without notice. Minarik Corporation and its Divisions make no warranty of any kind with respect to this material, including, but not limited to, the implied warranties of its merchantability and fitness for a given purpose. Minarik Corporation and its Divisions assume no responsibility for any errors that may appear in this manual and make no commitment to update or keep current the information in this manual.

Printed in the United States of America.

Safety Warnings

- This symbol  denotes an important safety tip or warning. Please read these sections carefully prior to performing any of the instructions contained in that section.
- Have a qualified electrical maintenance technician install, adjust, and service this equipment. Follow the National Electrical Code and all other applicable electrical and safety codes, including the provisions of the Occupational Safety and Health Act (OSHA) when installing equipment.
- Reduce the chance of an electrical fire, shock, or explosion by proper grounding, over current protection, thermal protection, and enclosure. Follow sound maintenance procedures.
- The VISI-TACH® is isolated from earth ground. Circuit potentials are at 115 VAC or 230 VAC above earth ground. Avoid direct contact with the printed circuit board or with circuit elements to prevent the risk of serious injury or fatality. Use a non-metallic screwdriver for any necessary adjustments.



Contents

Specifications	1
Dimensions	2
General Information	3
Installation	4
General installation information	4
Screw terminal block	5
Mounting	6
Shielded cable	7
Connections	8
Programming	9
Slide switch	10
DIP switches	10
Rotary DIP switches - time base calculations	12
Application Examples	15
Mode 1 tachometer mode - example 1	15
Mode 1 tachometer mode - example 2	17
Mode 2 totalizer mode	22
Mode 3 rate monitor mode	24
Mode 4 rate monitor mode (min-sec format)	26

Specifications

AC Line Voltage	
VT7-115	115 VAC +/- 10%, 50/60 Hertz, 5.5 Watts
VT7-230	230 VAC +/- 10%, 50/60 Hertz, 5.5 Watts
Programmable Power Supply Output	
5 VDC @ 50 mA	50 mA, Regulated Source, +/- 4%
12 VDC @ 25 mA	25 mA, Unregulated Source, +/- 20%
Operating Temperature Range	10°C–40°C
Maximum Input Rate	20000 Pulses per Second
Feedback Frequency Range	10 – 20000 Hz
LED Readout Size	0.7 inches

Dimensions

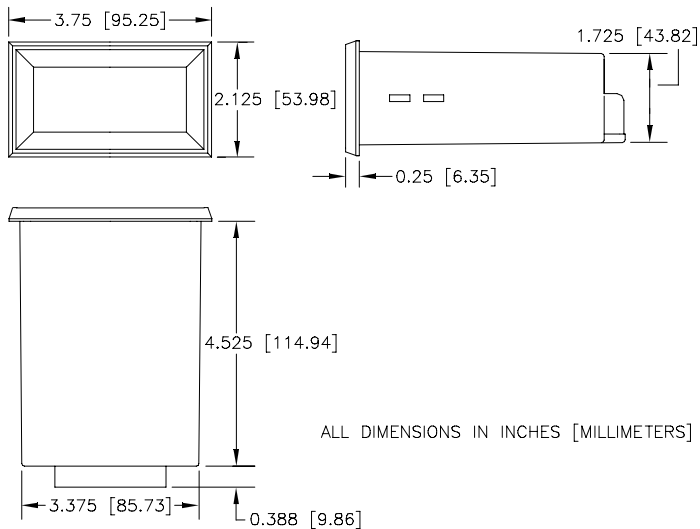

Figure 1. Model VT7-115 and Model VT7-230
Multi-Functional Digital Indicator Dimensions

General Information

Minarik Corporation's VISI-TACH® models VT7-115 and VT7-230 provide a means for monitoring the speed of rotating shafts using a digital velocity transducer. Speed transducers such as magnetic pickup, optical encoders or hall effect sensors convert motor speed into a small signal frequency which is supplied to the VT7.

The VT7 is a multi-functional device and can be programmed for use as a tachometer for display of revolutions per minute, feet per minute, etc. It can also be used as a totalizer, a rate monitor with a display of an inverse frequency, or a rate monitor with a time format in hours and minutes, or minutes and seconds.

The unit is programmable using a series of switches, located under the rear panel access cover. The variables programmed using these switches are the power supply (5 or 12 VDC), the type of feedback (magnetic pickup or optical encoder), decimal point location, and the mode the unit will operate in. The rotary switches program the time base in seconds. Detailed explanations of each one of these items follow in the programming section of this manual (page 9).

Installation

General installation information

The VT7 components are sensitive to electrostatic fields. Avoid contact with the circuit board directly.

Protect the VT7 from dirt and moisture. Provide adequate clearance for wiring and programming. This takes place at the back of the unit.

Mount the VT7 away from other heat sources. Operate within the specified ambient operating temperature range. The operating temperature range for the VT7 is 10°C through 40°C.

Prevent loose connections by avoiding excessive vibration of the VT7.



Screw terminal block

Connections to Minarik's VT7 digital indicator are made to a screw terminal block. The screw terminal block has a similar connection style to the one shown below.

Using a screwdriver, turn the terminal block screw counter-clockwise to open the wire clamp. Insert stripped wire into the wire clamp. Turn the terminal block screw clockwise to clamp the wire.

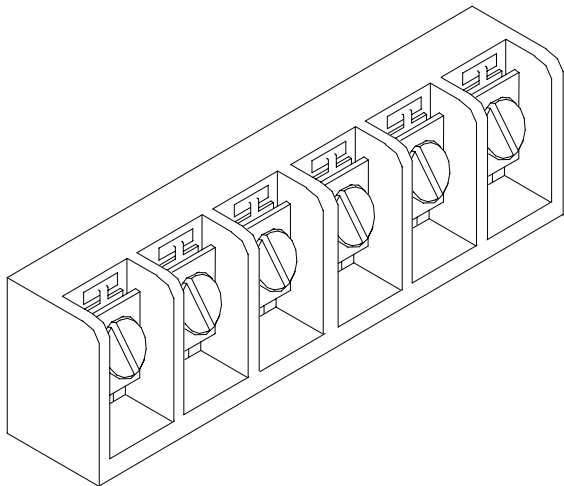

Fig. 2. Screw Terminal Block

Mounting

1. Cut a rectangular opening 1-25/32 inches [45mm] high by 3-3/8 inches [86mm] wide in your panel.
2. Unscrew the two mounting bracket screws until the threaded end is almost flush with the threaded bushing.
3. Place the VISI-TACH[®] through the panel opening and install the mounting bracket by engaging the two hooks on each bracket into the two slots on each side of the unit, with the threaded end of the screws towards the back of the panel.
4. Screw the two mounting bracket screws in until they “bite” into the rear of the panel. The screws should be tight enough to prevent the VISI-TACH[®] from moving, but do NOT over tighten the screws or you may damage your panel.

Shielded cable

Use shielded cable when logic lines are longer than 18 inches (475 mm). Logic lines of this length act as an antenna and can pick up noise from other devices or other ground wires, or voltage from power lines that can cause erratic operation. Attach the shield to the COM terminal on the back of the VT7 or the pickup source only.

It may be necessary to earth ground one end of the shielded cable. **Do not earth ground both ends of the shield.**

Connections

1. Connect the AC power line input on terminals L1 and L2.
This voltage is 115 VAC for the VT7-115 and 230 VAC for the VT7-230.
2. Connect the pickup, encoder or transducer on the terminals as indicated in the drawing below.

IMPORTANT! To prevent possible interference do NOT run pickup, encoder, or transducer cable in same conduit as the AC line.

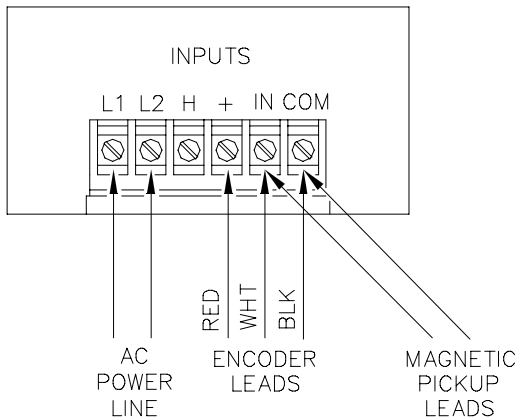

Fig. 3. Connection Diagram

Programming

The VT7 may be programmed before installing it into the panel, and before connecting to the AC line and the pickup, encoder or transducer, or after the entire system is set up. For easier handling, it is usually more convenient to program the VT7 before it is set in the panel.

For access to the programming switches, remove the two screws holding the rear cover to the case and remove the cover. The switches are illustrated in Figure 4.

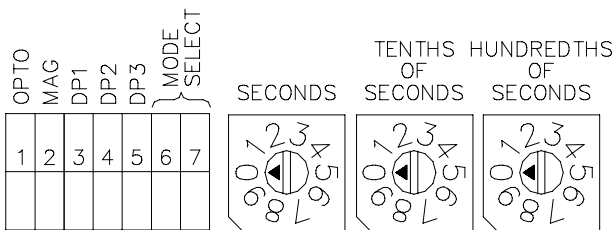

Fig. 4. VT7 Programming Switches

Slide switch

The position of the slide switch determines the power supply output. Set the slide switch to +5 or +12VDC to power an optical encoder. For accuracy and current output of this power supply see the specifications on page 1.

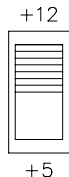

Fig. 5. VT7 Power Supply Slide Switch

DIP switches

To change the position of the DIP switches use a small screwdriver to push the DIP to the desired position. The DIP switch block has a similar construction style to one shown below (Figure 6). In the figure, the DIP switches are set for:

optical encoder (1 on and 2 off),
 decimal point 00.00 (3 off, 4 on, and 5 off) ,
 and tachometer mode (6 and 7 off).

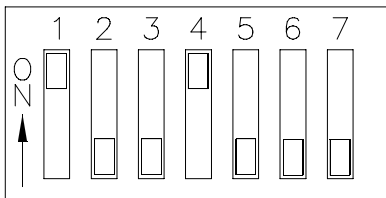

Fig. 6. VT7 DIP Switches

Feedback type. DIP switches 1 and 2 are dependent upon which type of feedback has been selected. See the table below for the settings.

Feedback Type	Switch #1	Switch #2
Magnetic pickup	OFF	ON
Optical encoder	ON	OFF

Decimal point selection. DIP switches 3, 4 and 5 determine where the decimal point will light in the display. See the table below for the settings. Only one switch may be on at any time.

Decimal Location	SW#3	SW#4	SW# 5
000.0	ON	OFF	OFF
00.00	OFF	ON	OFF
0.000	OFF	OFF	ON
0000	OFF	OFF	OFF

Mode selection. To select the mode in which VT7 will operate, use DIP switches 6 and 7.

Mode of Operation	SW#6	SW#7
Tachometer (1)	OFF	OFF
Totalizer (2)	OFF	ON
Rate Monitor Mode (3)	ON	OFF
Rate Monitor Mode (4)	ON	ON

Mode 1 is the **tachometer mode** (set 6 OFF and 7 OFF). The tachometer mode displays the monitored shaft speed or a multiple of it. The display can be frozen to the last reading by shorting terminal COM to terminal H.

Mode 2 is the **totalizer mode** (set 6 OFF and 7 ON). In this mode the unit displays continuous count of pulses received from the speed transducer. The display will turn over to 0000 after either 10,000 pulses have been received from the speed transducer or the unit has been reset. The display can be reset to zero by shorting terminal COM to terminal H.

Mode 3 is the **rate monitor mode** (set 6 ON and 7 OFF). This mode displays the time in process (or a linear multiple of it) in seconds. The display in the rate monitor mode is inversely proportional to the monitored shaft speed.

Mode 4 is the **rate monitor mode (min:sec or hour:min format)** (set 6 ON and 7 ON). In this mode the unit displays the number in time format. This display can be used to read minutes and seconds, or hours and minutes. The display can be frozen to the last reading by shorting terminal COM to terminal H.

Rotary DIP switches - time base calculations

The programming variable which determines the display reading is called the time base. The time base is the time interval the VT7 uses to count the pulses from the speed transducer and issue the result to the display.

The rotary DIP switches program the time base, in seconds, from 0.01 seconds to 10.00 seconds. Settings of all zeros is equal to a time base of 10.00 seconds. An explanation of the time base calculation begins on page 14. The time base is programmed for modes 1, 3, and 4 only.

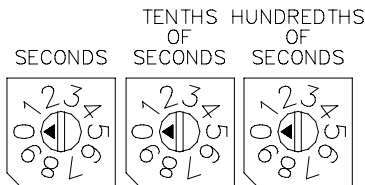

Fig. 7. VT7 Rotary DIP Switches

Ideally, the time base should be set between .67 seconds and 2 seconds. If the time base is set below .67 seconds, the display will update too often and tend to flicker. If the time base is set greater than two seconds, the display reading will not update often enough and may lag the actual speed of the application.

To program the rotary switches, use a small screwdriver and set the pointer mark to the desired number.

The following application variables must be known before calculating the time base (t):

DDN = The desired display number. DDN is the known display value at a certain shaft speed (RPM). It should be 4 digits and ignore any decimal point present.

RPM = Revolutions per minute of the monitored shaft at the time when the DDN is known.

PPR = Pulses per revolution of the pickup, encoder or transducer. This is the number of teeth on the pickup wheel or lines on the optical encoder.

Mode 1 (tachometer mode). The time base (t) is a variable which scales the RPM of the monitored shaft at the location of the speed transducer.

$$t = \frac{(DDN)(60)}{(RPM)(PPR)}$$

The RPM and DDN in the above equation are arbitrary values. Any RPM value may be chosen. The desired display number for the RPM selected is then determined by the user's application.

Mode 2 (totalizer mode). Mode 2 has no time base.

Mode 3 (rate monitor mode). To calculate the time base in mode 3 use the equation below:

$$t = \frac{250,000}{(DDN)(RPM)} \quad X \quad \frac{60}{PPR}$$

Mode 4 (rate monitor mode (min:sec/hour:min format)).

In this mode we must convert the DDN to an hours and minutes (or minutes and seconds) format. This is done with the following equation:

$$DDN = 60X + Y$$

where X = hours and Y = minutes when operating in the hours and minutes mode, and X = minutes and Y = seconds when operating in the minutes and seconds mode.

Calculate the time base with the following equation using the DDN calculated with the equation above:

$$t = \frac{250,000}{(DDN)(RPM)} \quad X \quad \frac{60}{PPR}$$

Application Examples

Mode 1 tachometer mode - example 1

Application. A PK1 magnetic pick up (PPR=30) is mounted on a motor and is connected to a VT7. The VT7 will display the speed of the motor directly. Calculate the required time base.

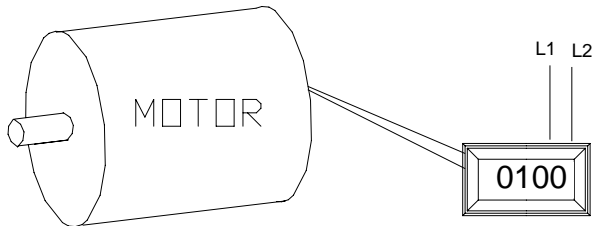

Solution. Using the equation on page 14 with arbitrary values of RPM=100, and DDN=100 the time base becomes

$$t = \frac{(DDN)(60)}{(RPM)(PPR)} = \frac{(100)(60)}{(100)(30)} = 2 \text{ seconds}$$

This is the standard time base that the factory sets into the VT7 for shipment. See page 16 for a diagram of the switch settings for this example.

Switch settings - tachometer mode - example one

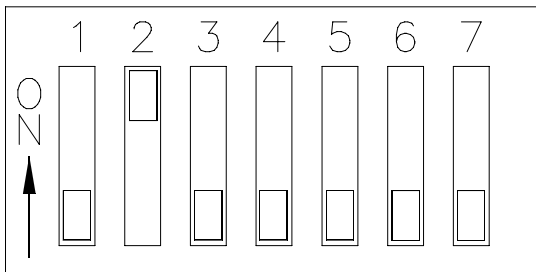

Fig. 8. Tachometer Mode-Example One DIP Switch Settings

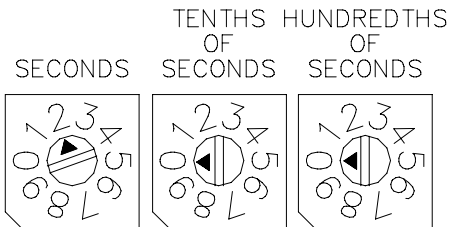
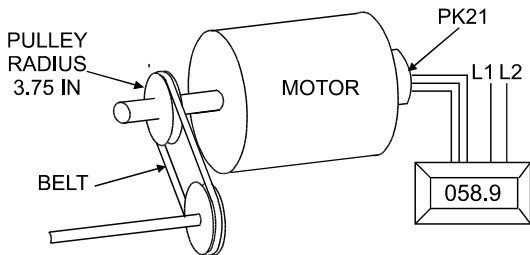

Fig. 9. Tachometer Mode Example One Rotary DIP Switch Settings

Mode 1 tachometer mode - example 2

Application. A PK21-30 encoder (30 lines per revolution) is monitoring the speed of a motor with a maximum of 1800 RPM. The pulley on the motor has a radius of 3.75 inches. The user wishes to have the VT7 display the speed of a belt, which is mounted on the pulley, in feet per second.



Find:

- The required time base (t).
- The error due to rounding the time base.
- The display range in feet per second if the motor speed ranges from 60 to 1800 RPM.
- A method for lowering the error.

Solution-a. Start by obtaining a conversion factor between motor speed in RPM to belt speed in feet per second. Use an arbitrary speed of 1 RPM for the calculation.

$$1 \text{ RPM} = \frac{1 \text{ revolution}}{\text{minute}}$$

$$1 \text{ RPM} = \frac{1 \text{ rev}}{\text{minute}} \times \frac{2(\pi)(r)}{\text{minute}} \times \frac{1 \text{ min}}{60 \text{ sec.}} \times \frac{1 \text{ foot}}{12 \text{ inches}}$$

$$1 \text{ RPM} = \frac{1 \text{ rev}}{\text{minute}} \times \frac{2(3.14)(3.75)}{\text{minute}} \times \frac{1 \text{ min}}{60 \text{ sec.}} \times \frac{1 \text{ foot}}{12 \text{ inches}}$$

$$= .0327 \text{ feet per second}$$

Use the equation on page 14 to calculate the time base:

$$t = \frac{(\text{DDN})(60)}{(\text{RPM})(\text{PPR})} = \frac{(.0327)(60)}{(1)(30)} = .06545 \text{ seconds}$$

$$= .07 \text{ seconds rounded}$$

Solution-part b. The error is calculated as follows:

$$\% \text{ error} = \frac{\text{rounded value} - \text{original value}}{\text{original value}} \times 100$$

$$= \frac{0.07 - 0.06545}{0.06545} \times 100 = 6.95\%$$

Solution-part c. To determine the display range calculate the minimum(min) and maximum(max) speed in feet per second:

$$1 \text{ RPM} = 0.0327 \text{ ft./sec.}$$

$$\begin{aligned} \text{Min speed} = 30 \text{ RPM} &= (30 \text{ RPM}) \times \frac{0.0327 \text{ ft./sec.}}{1 \text{ RPM}} \\ &= 0.98175 \text{ feet/second or about 1 foot per second.} \end{aligned}$$

$$\begin{aligned} \text{Max speed} = 1800 \text{ RPM} &= (1800 \text{ RPM}) \times \frac{0.0327 \text{ ft./sec.}}{1 \text{ RPM}} \\ &= 58.905 \text{ feet/second or about 59 feet per second.} \end{aligned}$$

This means the display will range from about 0001 to 0059 feet per second.

Solution-part d. The error due to rounding may be decreased by increasing the display value by a factor of 10 and introducing a decimal point. To do this set DIP switch DP1 on. The VT7 will read a speed of 10 feet per second as 10.0 feet per second.

Our new time base becomes:

$$\begin{aligned} t &= \frac{(\text{DDN})(60)}{(\text{RPM})(\text{PPR})} = \frac{(.327)(60)}{(1)(30)} \\ &= 0.654 \text{ sec.} = 0.65 \text{ second (rounded)} \end{aligned}$$

$$\begin{aligned}\% \text{ error} &= \frac{\text{rounded value} - \text{original value}}{\text{original value}} \quad \times \quad 100 \\ &= \frac{0.65 - 0.6545}{0.6545} \quad \times \quad 100 \quad = .69\%\end{aligned}$$

The new display range is:

$$\begin{aligned}\text{Min speed} &= 30 \text{ RPM} = (30 \text{ RPM}) \times \frac{0.327 \text{ ft./sec.}}{1 \text{ RPM}} \\ &= 9.818 \text{ feet/second or about } 10 \text{ foot per second.}\end{aligned}$$

$$\begin{aligned}\text{Max speed} &= 1800 \text{ RPM} = (1800 \text{ RPM}) \times \frac{0.327 \text{ ft./sec.}}{1 \text{ RPM}} \\ &= 589.05 \text{ feet/second or about } 589 \text{ feet per second.}\end{aligned}$$

The display will now range from about 0010 to 0589 feet per second reducing the error by a factor of 10. By placing DIP switch DP1 on the display will read 001.0 to 058.9.

The error due to rounding could be decreased by further increasing the DDN by a factor of 10 again and moving the decimal point (01.00 to 58.90). See page 21 for a diagram of the switch settings for this example.

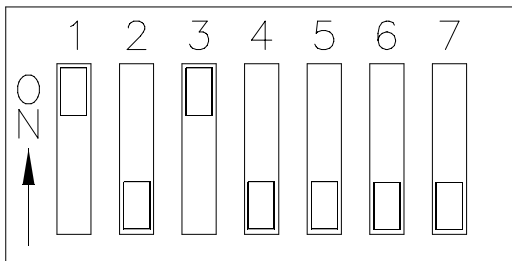
Switch settings - tachometer mode - example two

**Fig. 10. Tachometer Mode-Example Two
DIP Switch Settings**

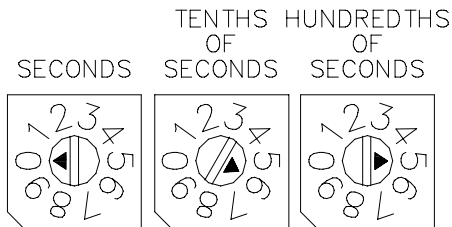

**Fig. 11. Tachometer Mode Example Two
Rotary DIP Switch Settings**

Mode 2 totalizer mode

Application. A VT7 is set for the totalizer mode with a PK21-30 (30 lines per revolution) encoder. The application speed is 500 RPM. Calculate the output frequency of the PK21-30 and the length of time that the display will count before rolling over.

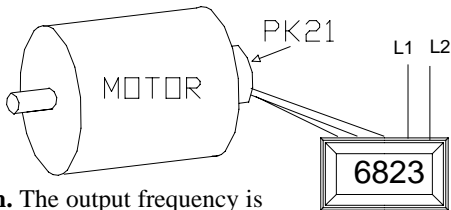

Solution. The output frequency is

$$f = \frac{(\text{rev.})}{(\text{min.})} \times \frac{(\text{pulses})}{(\text{rev.})} \times \frac{(1 \text{ min.})}{(60 \text{ sec.})}$$

$$f = \frac{(500)}{(\text{min.})} \times \frac{(30)}{(\text{rev.})} \times \frac{(1 \text{ min.})}{(60 \text{ sec.})} = 250\text{Hz}$$

The accumulated count is given by

$$\text{count} = (\text{rate})(\text{time}) = (f)(\text{time}) = \frac{(\text{RPM})(\text{PPR})}{60} (\text{time})$$

Solving this equation for time yields:

$$\text{time} = \frac{(\text{count})}{(f)} = \frac{(10,000)}{(250)} = 40 \text{ seconds}$$

See page 23 for diagrams of the switch settings for this example. There is not time base for mode 2.

Switch settings - totalizer mode example

Fig. 12. Totalizer Mode Example DIP Switch Settings

Mode 3 rate monitor mode

Application. A motor, and a variable speed drive are powering a conveyor belt carrying components. A 60 tooth magnetic pick up, mounted to the motor shaft, sends a signal to the VT7. It takes 50 seconds for a component to travel the length of the belt when the motor speed is 1000 RPM. Calculate the required time base to display the time necessary in seconds for the components to travel the length of the belt.

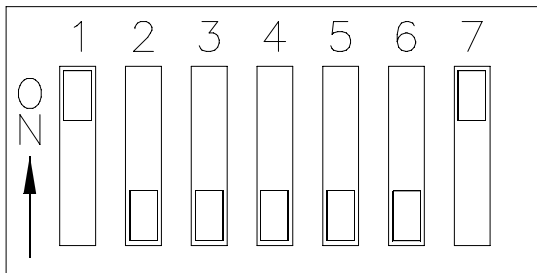
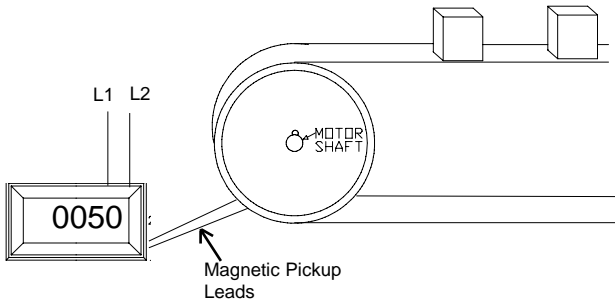

Solution. It is known that time in process (DDN) is 50 seconds when the motor speed is 1000 RPM. From the equation on page 14 we have,

$$t = \frac{250,000}{(\text{DDN})(\text{RPM})} \times \frac{60}{\text{PPR}} = \frac{250,000}{(50)(1000)} \times \frac{60}{60}$$

$$= 5 \text{ seconds}$$

See page 25 for diagrams of the switch settings for this example.

Switch settings - rate monitor mode example

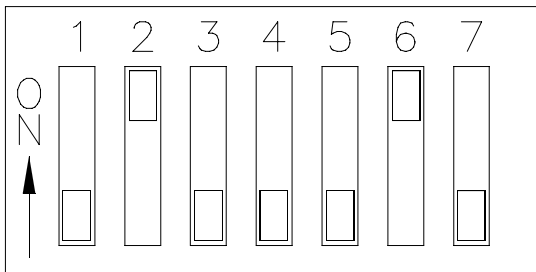

Fig. 13. Mode 3 Example DIP Switch Settings

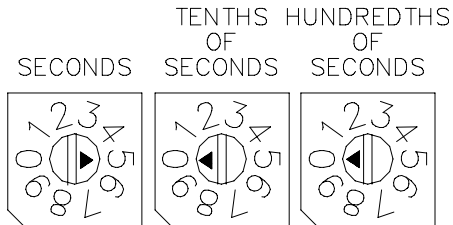
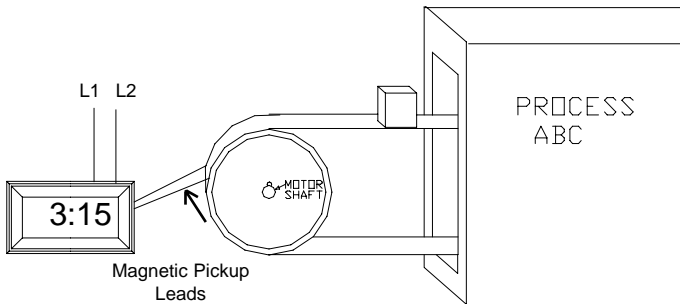

Fig. 14. Mode 3 Example Rotary
DIP Switch Settings

Mode 4 rate monitor mode (min:sec or hour:min format)

Application. A motor and a variable speed drive are powering a process conveyor. A 60 tooth magnetic pickup is mounted on the back of the motor and sends a signal to the VT7. The VT7 will display the time taken in minutes and seconds for the process to complete. It is known that it takes 3 minutes and 15 seconds to complete the process when the motor speed is 1000 RPM. Calculate the required time base for this application.



Solution. Using the equation on page 14 we have

$$\begin{aligned}
 t &= \frac{250,000}{(60X+Y)(\text{RPM})} \times \frac{60}{\text{PPR}} \\
 &= \frac{250,000}{[(60)(3)+15](1000)} \times \frac{60}{60} = 1.28 \text{ seconds}
 \end{aligned}$$

See page 27 for a diagram of the switch settings for this example.

Switch settings - rate monitor mode (min:sec or hour:min format) example

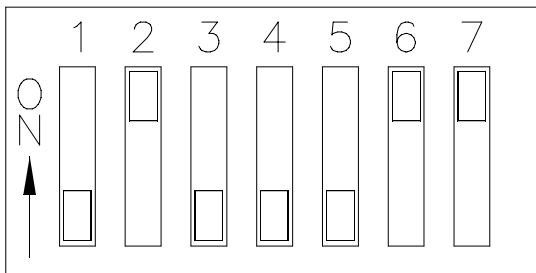

Fig. 15. Mode 4 Example DIP Switch Settings

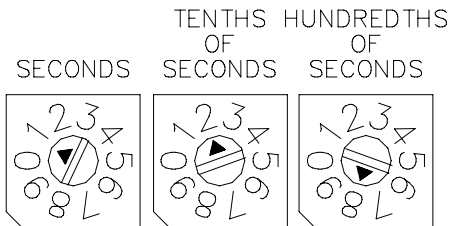

Fig. 16. Mode 4 Example Rotary DIP Switch Settings

Limited Warranty

A. Warranty - Minarik Corporation (referred to as "the Corporation") warrants that its products will be free from defects in workmanship and material for two (2) years from date of shipment thereof, or 6,000 hours, whichever comes first. Within this warranty period, the Corporation will repair or replace such products that are: (1) returned to Minarik Corporation, 901 East Thompson Avenue, Glendale, CA 91201-2011 USA; and, (2) determined by the Corporation to be defective.

This warranty shall not apply to any product that has been subject to misuse, negligence, or accident; or misapplied; or repaired by unauthorized persons; or improperly installed. The Corporation is not responsible for removal, installation, or any other incidental expenses incurred in shipping the product to and from the repair point.

B. Disclaimer - The provisions of Paragraph A are the Corporation's sole obligation and exclude all other warranties of merchantability for use, express or implied. The Corporation further disclaims any responsibility whatsoever to the customer or to any other person for injury to the person or damage or loss of property of value caused by any product that has been subject to misuse, negligence, or accident, or misapplied or modified by unauthorized persons or improperly installed.

C. Limitations of Liability - In the event of any claim for breach of any of the Corporation's obligations, whether express or implied, and particularly of any other claim or breach of warranty contained in Paragraph A, or of any other warranties, express or implied, or claim of liability that might, despite Paragraph B, be decided against the Corporation by lawful authority, the Corporation shall under no circumstances be liable for any consequential damages, losses, or expense arising in connection with the use of, or inability to use, the Corporation's product for any purpose whatsoever.

An adjustment made under warranty does not void the warranty, nor does it imply an extension of the original two (2) year or 6,000 hour warranty period. Products serviced and/or parts replaced on a no-charge basis during the warranty period carry the unexpired portion of the original warranty only.

If for any reason any of the foregoing provisions shall be ineffective, the Corporation's liability for damages arising out of its manufacture or sale of equipment, or use thereof, whether such liability is based on warranty, contract, negligence, strict liability in tort, or otherwise, shall not in any event exceed the full purchase price of such equipment.

Any action against the Corporation based upon any liability or obligation arising hereunder or under any law applicable to the sale of equipment or the use thereof, must be commenced within one year after the cause of such action arises.



901 East Thompson Avenue
Glendale, California 91201-2011

Phone: (818) 502-1528

Fax: (818) 502-0716

www.minarikcorp.com

Document number 250-0257, Revision 1

Printed in the U.S.A – 5/98

North America \$10.00, Outside North America \$11.00