



USER'S MANUAL

M1740009.00

Pulse-Width Modulated,
Adjustable Speed Drives
for DC Brush Motors

Copyright © 1997 by
Leeson Corporation

All rights reserved. No part of this manual may be reproduced or transmitted in any form without written permission from Leeson Corporation. The information and technical data in this manual are subject to change without notice. Leeson Corporation and its Divisions make no warranty of any kind with respect to this material, including, but not limited to, the implied warranties of its merchantability and fitness for a given purpose. Leeson Corporation and its Divisions assume no responsibility for any errors that may appear in this manual and make no commitment to update or to keep current the information in this manual.

Printed in the United States of America.

Safety Warnings

- Throughout this manual, this symbol  denotes an important safety message. Please read these sections very carefully before performing any of the instructions contained in this manual.
- Have a qualified electrical maintenance technician install, adjust and service this equipment. Follow the National Electrical Code and all other applicable electrical and safety codes, including the provisions of the Occupational Safety and Health Act (OSHA), when installing equipment.
- Reduce the chance of an electrical fire, shock, or explosion by proper grounding, over-current protection, thermal protection, and enclosure. Follow sound maintenance procedures.
- **It is possible for a drive to run at full speed as a result of a component failure.** In order to stop the drive in an emergency, please ensure that a master switch has been placed in the AC power line.
- **This drive is not isolated from earth ground.** Circuit potentials are at 115 VAC above earth ground. Avoid direct contact with the printed circuit board or with circuit elements to prevent the risk of serious injury or fatality. Use a non-metallic screwdriver for adjusting the calibration trimpots.

Contents

Specifications	1
Dimensions	2
Installation	3
Mounting	3
Wiring	4
Line fuse	5
Speed adjust potentiometer	6
Quick-connect terminal block	7
Connections	8
Voltage follower	9
Operation	10
Startup	10
Diagnostic LEDs	11
Line starting and line stopping	11
Inhibit switch	12
Dynamic braking	12
Calibration	14
MIN SPD	14
MAX SPD	14
IR COMP	15
TORQUE	15

Application Notes	17
Multiple fixed speeds	17
Adjustable speeds using potentiometers in series	18
Independent adjustable speeds	19
RUN/JOG switch	20
Reversing	21
Troubleshooting	22
Block Diagrams	25
Limited Warranty	inside back cover

Index of Illustrations

Fig.	Description	Page
1.	Dimensions	2
2.	Fuseholder	5
3.	Speed Adjust Potentiometer	6
4.	Quick-Connect Terminal Block	7
5.	Drive Connections	8
6.	Voltage Follower Connections	9
7.	Diagnostic LEDs	11
8.	Inhibit Switch	12
9.	Dynamic Brake Connection	13
10.	Typical TORQUE and IR COMP settings	16
11.	Multiple Fixed Speeds	17
12.	Adjustable Fixed Speeds Using Potentiometers In Series	18
13.	Independent Adjustable Speeds	19
14.	RUN/JOG Switch	20
15.	Reversing Circuit Connection	21
16.	Block Diagram	25
17.	Input Circuit Diagram	26

Specifications

Model	M1740009.00
AC Line Voltage	115 VAC, $\pm 10\%$, 50/60 Hz, single phase
Horsepower Range (with 130 VDC motors)	1/20 – 1/3 HP
Armature Voltage	0 – 130 VDC
Maximum Continuous Armature Current	2 ADC
Form Factor (at base speed)	1.05
Acceleration Time (with load)	1 second
Deceleration Time (with load)	2 seconds
Analog Input Voltage Range (isolated; S1 to S2)	0 – 5 VDC
Input Impedance (S1 to S2)	> 100K ohms
Speed Regulation	1% of base speed or better
Ambient Temperature Range	10°C–40°C
Weight	0.6 lb

Installation

Mounting

- Drive components are sensitive to electrostatic fields. Avoid direct contact with the circuit board. Hold drive by the chassis only.
- Protect the drive from dirt, moisture, and accidental contact. Provide sufficient room for access to the terminal block and calibration trim pots.
- Mount the drive away from heat sources. Operate the drive within the specified ambient operating temperature range.
- Prevent loose connections by avoiding excessive vibration of the drive.
- Mount drive with its board in either a horizontal or vertical plane. Six 0.19 in. (5 mm) wide slots in the chassis accept #8 pan head screws. Fasten either the large base or the narrow flange of the chassis to the subplate.
- The chassis must be earth grounded. Use a star washer beneath the head of at least one of the mounting screws to penetrate the anodized chassis surface and reach bare metal.

Wiring

- Use 18 AWG wire for speed adjust potentiometer wiring. Use 16 AWG wire for motor and AC line voltage wiring.
- Twist logic wires (for speed adjust potentiometer and inhibit) to avoid picking up unwanted electrical noise. Use shielded cable if wires are longer than 18 in. (46 cm).
- Keep logic wires away from power carrying lines or sources of electrical noise that can cause erratic operation. Never run speed adjust potentiometer or inhibit wires in the same conduit as the motor and AC line voltage wires.
- It may be necessary to earth ground the shielded cable. If noise is produced by devices other than the drive, ground the shield at the drive end. If noise is generated by a device on the drive, ground the shield at the end away from the drive. Do not ground both ends of the shield.

Line fuse

The M1740009.OO drive is protected by a 5 A, 250 V AC line fuses. The fuse does not have to be resized as long as the motor used is within the drive's specified horsepower range.

The fuse is mounted in the fuseholder (see Figure 2). To replace a blown fuse, use a screwdriver to turn the fuseholder knob counterclockwise. Remove the blown fuse and replace with a new fuse.

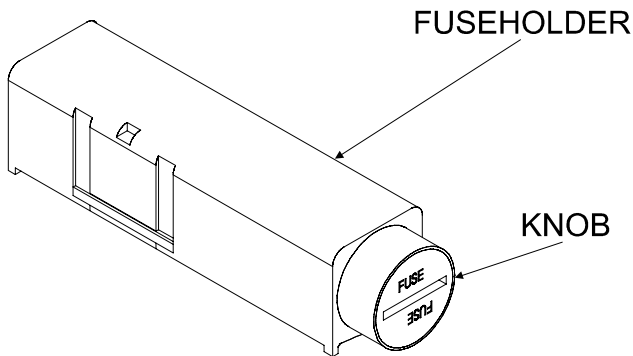

Figure 2. Fuseholder

Speed adjust potentiometer

Mount the speed adjust potentiometer through a 0.38 in. (10 mm) hole with the hardware provided (Figure 3). Install the circular insulating disk between the panel and the 10K ohm speed adjust potentiometer. Twist the speed adjust potentiometer wire to avoid picking up unwanted electrical noise. If potentiometer leads are longer than 18 in. (457 mm), use shielded cable (see Wiring section).

⚠ Warning

Be sure that the potentiometer tabs do not make contact with the potentiometer enclosure. Grounding the input will cause damage to the drive.

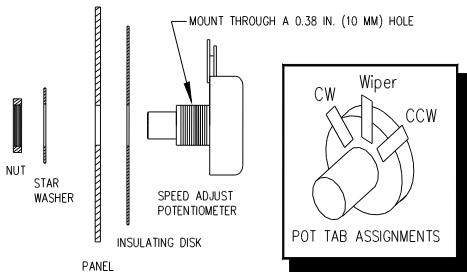

Figure 3. Speed Adjust Potentiometer

Quick-connect terminal block

The quick-connect terminal block has an 8-pin header block and 8-screw terminal plug (Figure 4). To use the quick-connect terminal block:

1. Carefully pull terminal plug from header block.
2. With a small flat-head screwdriver, turn terminal plug screw counterclockwise to open wire clamp.
3. Insert stripped wire into the large opening in front of the plug.
4. Turn the terminal plug screw clockwise to clamp the wire.
5. Repeat steps 2–4 for each terminal until all connections are made.
6. Insert plug into header until securely fastened.

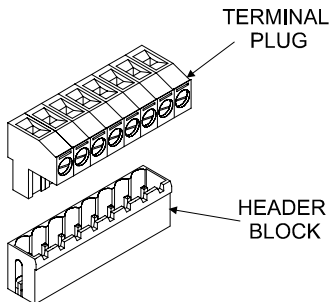

Figure 4. Quick-Connect Terminal Block

Connections

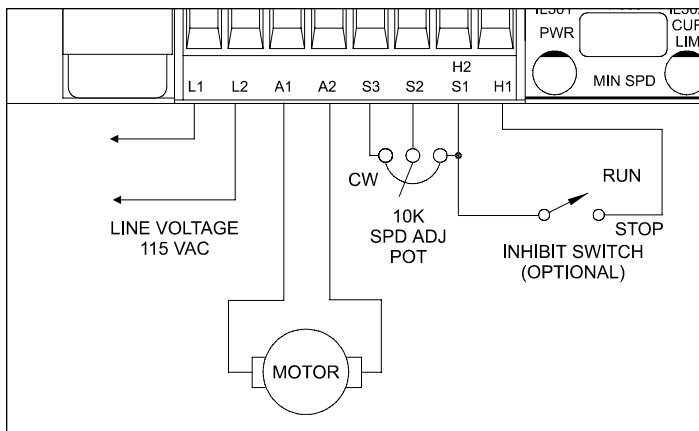

Figure 5. Drive Connections

ASSUMPTIONS: This drive series supplies motor voltage from its A1 and A2 terminals. It is assumed throughout this manual that when A1 is positive with respect to A2, the motor will rotate clockwise (CW) while looking at the output shaft protruding from the front of the motor. If this is opposite of the desired rotation, simply reverse the wiring to the motor from A1 and A2.

Voltage follower

Instead of using a speed adjust potentiometer, the drive may be wired to follow a 0–5 VDC voltage signal that is isolated from earth ground (Figure 6). Connect the signal input (+) to S2. Connect the signal common (–) to S1. Make no connection to S3. A potentiometer can be used to scale the analog input voltage.

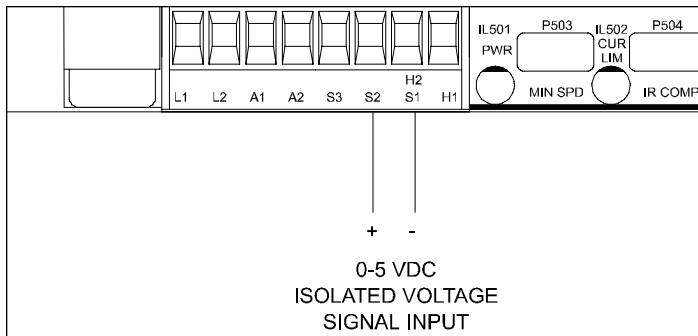

Figure 6. Voltage Follower Connections

Operation

Startup

Note: Before applying power, verify that no conductive material is placed on the printed circuit board.

To start the drive:

1. Turn the speed adjust potentiometer full counterclockwise (CCW). If the drive is following a voltage signal, set the voltage signal to 0 VDC.
2. Apply power.
3. Slowly advance the speed adjust potentiometer clockwise (CW). If the drive is following a voltage signal, slowly increase the voltage signal. The motor will slowly accelerate as the speed adjust potentiometer is turned CW, or the voltage signal is increased. Increase the signal until the desired speed is reached.
4. Remove power from the drive. The motor will coast to a stop.

If the motor or drive does not perform as described, disconnect the AC line voltage immediately. Refer to the Troubleshooting section, page 27, for further assistance.

Diagnostic LEDs

This drive is equipped with two diagnostic LEDs: power status (PWR) and current limit mode (CUR LIM). See Figure 7 for LED location.

POWER (PWR): Green LED lights whenever AC line voltage is applied to the drive.

CURRENT LIMIT (CUR LIM): Red LED lights whenever the drive reaches current limit.

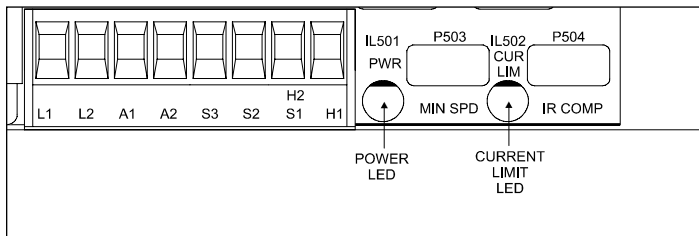

Figure 7. Diagnostic LEDs

Line starting and stopping

Line starting and stopping (applying and removing AC line voltage) is recommended for infrequent starting and stopping of a drive only. When AC line voltage is applied to the drive, the motor accelerates to the speed set by the speed adjust potentiometer. When AC line voltage is removed, the motor coasts to a stop.

Inhibit switch

An inhibit switch allows the motor to decelerate to zero speed when the switch is closed. Connect a single pole, single throw switch between H1 and H2 (see Figure 8). Close the switch to decelerate the motor to zero speed. Open the switch to accelerate the motor to set speed. An open-collector output rated for at least 10 mA (I_{CE}) may also be used as an inhibit switch. Wire the collector to H1, and the emitter to H2.

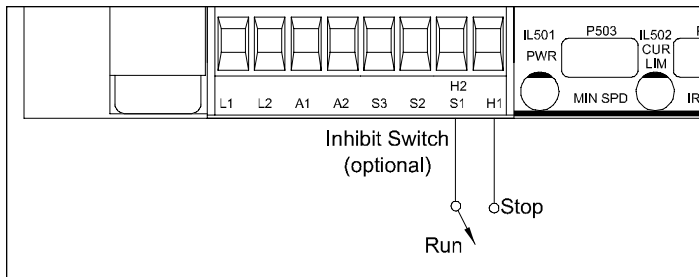

Figure 8. Inhibit Switch

Dynamic braking

Dynamic braking may be used to rapidly stop a motor (Figure 9). For the RUN/BRAKE switch, use a double pole, double throw switch rated for at least the maximum DC armature voltage and maximum braking current.

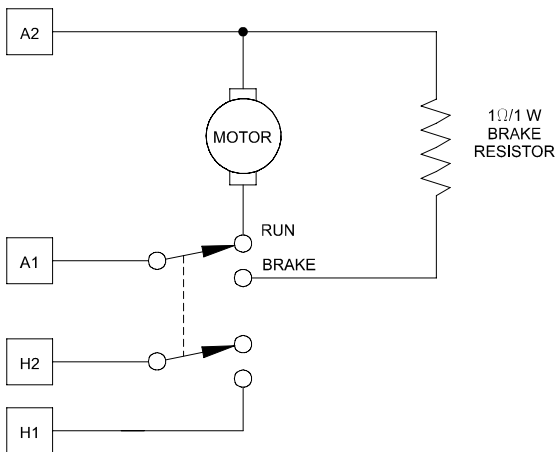

Figure 9. Dynamic Brake Connection

A 1 Ω , 1 W resistor is used as the dynamic brake resistor. For motors rated $1/17$ horsepower and lower, a dynamic brake resistor is not necessary since the armature resistance is high enough to stop the motor without demagnetization. In this case, replace the dynamic brake resistor with 12 gauge wire.

⚠ Warning

Wait for the motor to completely stop before switching it back to RUN. This will prevent high armature currents from damaging the motor or drive.

Calibration

Each drive is factory calibrated to its maximum horsepower rating. Readjust the calibration trimpot settings to accommodate lower horsepower motors.

All adjustments increase with CW rotation, and decrease with CCW rotation. Use a non-metallic screwdriver for calibration. Each trimpot is identified on the printed circuit board.

MINIMUM SPEED (MIN SPD)

The MIN SPD setting determines the motor speed when the speed adjust potentiometer is turned full CCW. It is factory set for zero speed.

To calibrate turn the speed adjust potentiometer full CCW. Adjust the MIN SPD trimpot until the motor has stopped, or is running at the desired minimum speed.

MAXIMUM SPEED (MAX SPD)

The MAX SPD setting determines the motor speed when the speed adjust potentiometer is turned full CW. It is factory set for maximum rated speed.

To calibrate, set the MAX SPD trimpot full CCW. Turn the speed adjust potentiometer full CW. Adjust the MAX SPD trimpot until the desired maximum motor speed is reached.

Note: Check the MIN SPD and MAX SPD adjustments after recalibrating to verify that the motor runs at the desired minimum and maximum speed.

REGULATION (IR COMP)

The IR COMP setting determines the degree to which motor speed is held constant as the motor load changes. It is factory calibrated for a 1/8 HP, 90 VDC motor.

Recalibrate the IR COMP setting when using a lower horsepower motor. Refer to the recommended IR COMP settings in Figure 10, or recalibrate using the following procedure:













If the motor does not maintain set speed as the load changes, gradually rotate the IR COMP trimpot CW. If the motor oscillates (overcompensation), the IR COMP trimpot may be set too high (CW). Turn the IR COMP trimpot CCW to stabilize the drive.

TORQUE

The TORQUE setting determines the maximum armature current output of the drive. It is factory calibrated for a 1/8 HP, 90 VDC motor.

Recalibrate the TORQUE setting when using a lower horsepower motor. Refer to the recommended TORQUE settings in Figure 10, or recalibrate using the following procedure:

1. With the power disconnected from the control, connect a DC ammeter (0–15 A minimum scale) in series with the armature.
2. Set the TORQUE trimpot to minimum (full CCW).
3. Connect power to the drive. The motor should remain stopped.
4. Lock the motor armature. Be sure that the motor is firmly mounted.
5. Set the speed adjust potentiometer to maximum (full CW).
6. Adjust the TORQUE trimpot CW slowly until the armature current is 120% of motor rated armature current.
7. Set the speed adjust potentiometer to minimum and remove the stall from the motor.

		1/4 HP 130 VDC 2500 RPM 1.40 ADC			1/10 HP 90 VDC 1725 RPM 1.10 ADC
* 		1/8 HP 90 VDC 1800 RPM 1.30 ADC			1/15 HP 90 VDC 1800 RPM 0.75 ADC
		1/8 HP 130 VDC 2500 RPM 1.00 ADC			1/20 HP 90 VDC 1750 RPM 0.56 ADC

* Factory Setting

**Figure 10. Typical TORQUE and IR COMP Settings
(actual settings may vary with each application)**

Application Notes

Multiple fixed speeds

Replace the speed adjust potentiometer with series resistors with a total series resistance of 10K ohms (Figure 11). Add a single pole, multi-position switch with the correct number of positions for the desired number of fixed speeds.

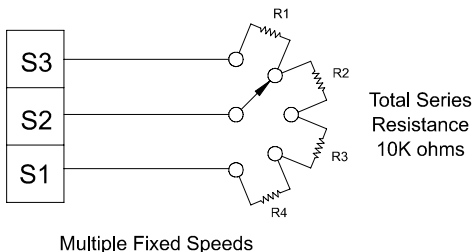

Figure 11. Multiple Fixed Speeds

Adjustable speeds using potentiometers in series

Replace the speed adjust potentiometer with a single pole, multi-position switch, and two or more potentiometers in series, with a total series resistance of 10K ohms. Figure 12 shows a connection for fixed high and low speed adjust potentiometers.

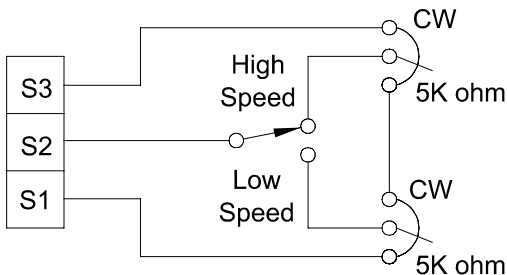

Figure 12. Adjustable Fixed Speeds Using Potentiometers in Series

Independent adjustable speeds

Replace the speed adjust potentiometer with a single pole, multi-position switch, and two or more potentiometers in parallel, with a total parallel resistance of 10K ohms. Figure 13 shows the connection of two independent speed adjust potentiometers that can be mounted at two separate operating stations.

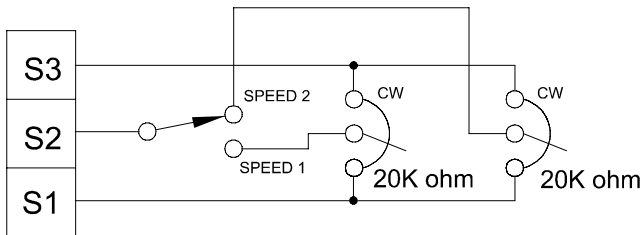

Figure 13. Independent Adjustable Speeds

RUN/JOG switch

Using a RUN/JOG switch is recommended in applications where quick stopping is not needed and frequent jogging is required. Use a single pole, single throw switch for the RUN/JOG switch, and a single pole, normally closed, momentary operated pushbutton for the JOG pushbutton (see Figure 14). When the RUN/JOG switch is set to JOG, the motor decelerates to zero speed. Press the JOG pushbutton to jog the motor. Return the RUN/JOG switch to RUN for normal operation.

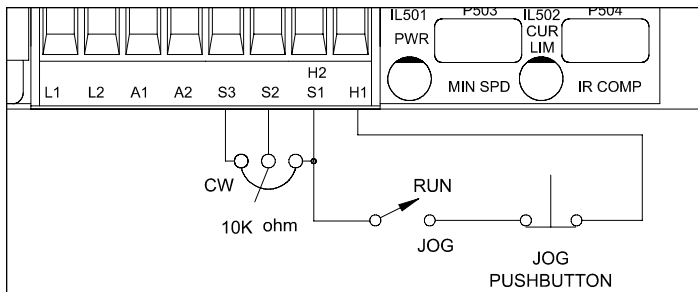

Figure 14. RUN/JOG Switch Connection

Reversing

A dynamic brake may be used when reversing the motor direction (Figure 18). Use a three pole, three position switch rated for at least the maximum DC armature voltage and maximum braking current. **Wait for the motor to stop completely before switching it to either the forward or reverse direction.**

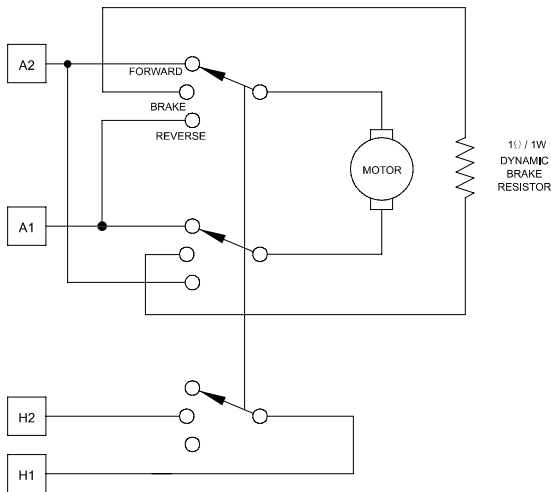

Figure 18. Reversing Circuit Connection

Troubleshooting

Warning

Dangerous voltages exist on the drive when it is powered. When possible, disconnect the AC line voltage from the drive while troubleshooting. Be alert. High voltages can cause serious or fatal injury.

Before troubleshooting

Perform the following steps before starting any procedure in this section:

- Disconnect AC line voltage from the drive.
- Check the drive closely for damaged components.
- Check that no conductive or other foreign material has become lodged on the printed circuit board.
- Verify that every connection is correct and in good condition.
- Verify that there are no short circuits or grounded connections.
- Check that the voltage selection switch settings match the AC line and output voltages.
- Check that the drive's rated armature and field outputs are consistent with the motor ratings.

Motor does not run

1. Check for blown fuses or tripped circuit breaker.
2. Verify that the speed adjust potentiometer is not set to zero speed position.
3. Verify that the inhibit terminals (H1 and H2) are not shorted together.
4. Verify that the drive is receiving AC line voltage.
5. Check that the drive is not in current limit. The red current limit (CUR LIM) LED must be off. If the red current limit LED is on, verify that the motor is not jammed. It may be necessary to increase the TORQUE setting if it is set to a value lower than the current rating of the motor.

Fuses or circuit breaker blows

1. Check all wiring for shorts, grounds, or misconnections.
2. Check that the drive is configured to match the motor rating.
3. Check that the motor is not jammed or restricted from movement.
4. Check that the fuse size is correct for the motor being driven.

Motor runs too fast at the maximum speed setting

1. Check that the MIN SPD and MAX SPD setting are not set too high.
2. Check that the field output connections are secure if you are using a shunt wound motor.

Motor will not stop when the speed adjust potentiometer is full counterclockwise

Turn the MIN SPD trimpot CCW until the motor stops.

Motor runs in the opposite direction

1. Remove AC line voltage.
2. Reverse connections to the motor armature.

Motor slows under load

1. Check that the drive has been correctly calibrated for the motor.
2. Check that the motor is not overloaded.
3. Readjust the IR COMP slightly CW until motor runs at proper speed.

Motor is unstable under load

Readjust the IR COMP setting slightly CCW until motor speed is stabilized.

Motor only runs at full speed

Check that S2 and S3 are not shorted together.

For additional assistance, contact your local Leeson distributor, or the factory direct: phone (414) 377-8810, fax (414) 377-3440.

Block Diagrams

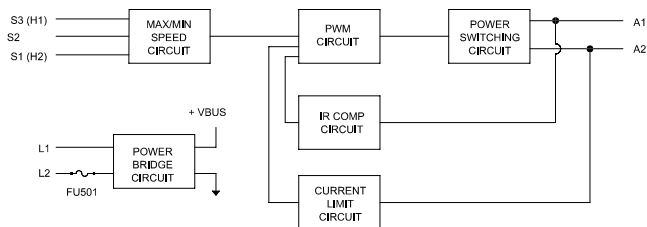

Figure 16. Block Diagram

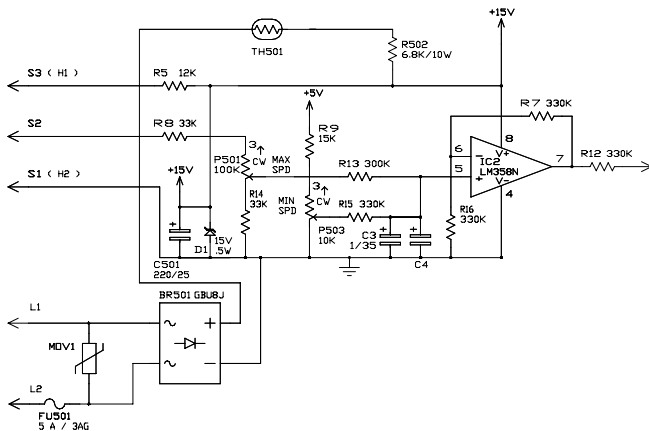

Figure 22. Input Circuit Diagram

Notes

Notes

Limited Warranty

A. Warranty - Leeson Corporation (referred to as "the Corporation") warrants that its products will be free from defects in workmanship and material for one (1) year or 3,000 hours, whichever comes first, from date of shipment thereof. Within this warranty period, the Corporation will repair or replace such products that are: (1) returned to Leeson Corporation, 2100 Washington Street, Grafton, WI 53024-0241 USA; and, (2) determined by the Corporation to be defective.

This warranty shall not apply to any product that has been subject to misuse, negligence, or accident; or misapplied; or repaired by unauthorized persons; or improperly installed. The Corporation is not responsible for removal, installation, or any other incidental expenses incurred in shipping the product to and from the repair point.

B. Disclaimer - The provisions of Paragraph A are the Corporation's sole obligation and exclude all other warranties of merchantability for use, express or implied. The Corporation further disclaims any responsibility whatsoever to the customer or to any other person for injury to the person or damage or loss of property of value caused by any product that has been subject to misuse, negligence, or accident, or misapplied or modified by unauthorized persons or improperly installed.

C. Limitations of Liability - In the event of any claim for breach of any of the Corporation's obligations, whether express or implied, and particularly of any other claim or breach of warranty contained in Paragraph A, or of any other warranties, express or implied, or claim of liability that might, despite Paragraph B, be decided against the Corporation by lawful authority, the Corporation shall under no circumstances be liable for any consequential damages, losses, or expense arising in connection with the use of, or inability to use, the Corporation's product for any purpose whatsoever.

An adjustment made under warranty does not void the warranty, nor does it imply an extension of the original one (1) year or 3,000 hour warranty period. Products serviced and/or parts replaced on a no-charge basis during the warranty period carry the unexpired portion of the original warranty only.

If for any reason any of the foregoing provisions shall be ineffective, the Corporation's liability for damages arising out of its manufacture or sale of equipment, or use thereof, whether such liability is based on warranty, contract, negligence, strict liability in tort, or otherwise, shall not in any event exceed the full purchase price of such equipment.

Any action against the Corporation based upon any liability or obligation arising hereunder or under any law applicable to the sale of equipment or the use thereof, must be commenced within one year after the cause of such action arises.



2100 Washington Street
Grafton, WI 53024-0241 U.S.A.
Phone: (414) 377-8810
Fax: (414) 377-3440

Document Number 250-0256, Revision 0
Printed in the U.S.A – 4/96
U.S.A. \$12.00, Canada \$13.00