



Copyright © 2002 by  
Minarik Corporation

All rights reserved. No part of this manual may be reproduced or transmitted in any form without written permission from Minarik Corporation. The information and technical data in this manual are subject to change without notice. Minarik Corporation and its Divisions make no warranty of any kind with respect to this material, including, but not limited to, the implied warranties of its merchantability and fitness for a given purpose. Minarik Corporation and its Divisions assume no responsibility for any errors that may appear in this manual and make no commitment to update or to keep current the information in this manual. MVD081202

Printed in the United States of America.

# Safety Warnings



- This symbol  denotes an important safety tip or warning. **Please read these instructions carefully** before performing any of the procedures contained in this manual.
- **DO NOT INSTALL, REMOVE, OR REWIRE THIS EQUIPMENT WITH POWER APPLIED.** Have a qualified electrical technician install, adjust and service this equipment. Follow the National Electrical Code and all other applicable electrical and safety codes, including the provisions of the Occupational Safety and Health Act (OSHA), when installing equipment.
- Reduce the chance of an electrical fire, shock, or explosion by proper grounding, over-current protection, thermal protection, and enclosure. Follow sound maintenance procedures.



**It is possible for a drive to run at full speed as a result of a component failure.** Minarik strongly recommends the installation of a master switch in the main power input to stop the drive in an emergency.

Circuit potentials are at 115 VAC or 230 VAC above earth ground. Avoid direct contact with the printed circuit board or with circuit elements to prevent the risk of serious injury or fatality. Use a non-metallic screwdriver for adjusting the calibration trimpots. Use approved personal protective equipment and insulated tools if working on this drive with power applied.

---

# Contents

|  |           |
|--|-----------|
| <b>Safety Warnings</b>                   | <b>i</b>  |
| <b>Regenerative Drives</b>               | <b>v</b>  |
| <b>Specifications</b>                    | <b>1</b>  |
| <b>Dimensions</b>                        | <b>2</b>  |
| <b>Installation</b>                      | <b>5</b>  |
| Mounting                                 | 5         |
| Wiring                                   | 6         |
| Shielding guidelines                     | 7         |
| Heat sinking                             | 8         |
| Speed adjust potentiometer               | 9         |
| Connections                              | 10        |
| Power, fuse and motor connections        | 10        |
| Motor                                    | 11        |
| Power input                              | 11        |
| Line fuse                                | 11        |
| Voltage follower                         | 15        |
| Voltage follower (-PCM models)           | 16        |
| Polarity reversal switch (-PCM models)   | 16        |
| +15 and -15 terminals                    | 18        |
| Line frequency switch                    | 19        |
| <b>Operation</b>                         | <b>20</b> |
| Before applying power:                   | 20        |
| Startup and shutdown                     | 21        |
| To start the drive:                      | 21        |
| Starting and Stopping Methods            | 22        |
| Automatic restart upon power restoration | 22        |
| Decelerate to a stop                     | 23        |
| Regenerative brake                       | 24        |

|  |                          |
|--|--------------------------|
| <b>Calibration</b>   | <b>25</b>                |
| MAX SPD  | 27                       |
| FORWARD TORQUE   | 28                       |
| REVERSE TORQUE   | 29                       |
| IR COMP  | 30                       |
| ACC-DEC  | 31                       |
| FWD SIG ADJ (-PCM models)  | 32                       |
| REV SIG ADJ (-PCM models)  | 32                       |
| <b>Application Notes</b>   | <b>34</b>                |
| Connection to Minarik DLC600                                       | 34                       |
| FWD-REV switch   | 35                       |
| FWD-STOP-REV switch  | 36                       |
| Independent Adjustable Speeds                                      | 37                       |
| Independent forward and reverse speeds                             | 38                       |
| Independent forward and reverse speeds<br>with FWD-STOP-REV switch | 39                       |
| <b>Troubleshooting</b>   | <b>40</b>                |
| Before applying power  | 40                       |
| Replacement Parts  | 44                       |
| <b>Certificate of Compliance</b>                                   | <b>45</b>                |
| AC Line Filters  | 46                       |
| Armature Filters   | 47                       |
| <b>Unconditional Warranty</b>                                      | <b>inside back cover</b> |

## Tables

|                                      |    |
|--------------------------------------|----|
| Table 1. Recommended Line Fuse Sizes | 12 |
| Table 2. Replacement Parts           | 44 |
| Table 3. AC Line Filters             | 46 |
| Table 4. Armature Filters            | 47 |

---

# Illustrations

|   |     |
|---|-----|
| Figure 1. Four Quadrant Operation . . . . .   | .vi |
| Figure 2. MMRG Dimensions . . . . .   | 2   |
| Figure 3. MMRG Dimensions<br>(Drive mounted on 223–0159 heat sink kit) . . . . .                  | 3   |
| Figure 4. MMRG-PCM Dimensions . . . . .   | 4   |
| Figure 5. Speed Adjust Potentiometer . . . . .  | 9   |
| Figure 6. Power and Motor Connections . . . . .   | 13  |
| Figure 7. Speed Adjust Potentiometer Connections . . . . .  | 14  |
| Figure 8. Voltage Follower Connection . . . . .   | 15  |
| Figure 9. Voltage Follower Connection (-PCM Models) . . . . .                                     | 17  |
| Figure 10. +15 and -15 Terminal Locations . . . . .   | 18  |
| Figure 11. Line Frequency Switch . . . . .  | 19  |
| Figure 12. RUN/STOP Switch . . . . .  | 23  |
| Figure 13. INHIBIT Terminals . . . . .  | 24  |
| Figure 14. Calibration Trimpot Layout . . . . .   | 26  |
| Figure 15. Recommended IR COMP, REVERSE TORQUE, and<br>FORWARD TORQUE Settings . . . . .          | 33  |
| Figure 16. MMRG Connection to DLC600 . . . . .  | 34  |
| Figure 17. Forward-Reverse Switch . . . . .   | 35  |
| Figure 18. Forward-Stop-Reverse Switch . . . . .  | 36  |
| Figure 19. Independent Adjustable Speeds (Forward Direction) . . . . .                            | 37  |
| Figure 20. Independent Forward and Reverse Speeds . . . . .                                       | 38  |
| Figure 21. Independent Forward and Reverse Speeds with a<br>Forward-Stop-Reverse Switch . . . . . | 39  |

---

# Regenerative Drives

Most non-regenerative, variable speed, DC drives control current flow to a motor in one direction. The direction of current flow is the same direction as the motor rotation. Non-regenerative drives operate in Quadrant 1, and also in Quadrant 3 if the drive is reversible (see Figure 1). Motors must stop before reversing direction. Unless dynamic braking is used, non-regenerative drives cannot oppose an overhauling load, and cannot decelerate a load faster than coasting to a lower speed.

Regenerative drives operate in two additional quadrants: Quadrant 2 and Quadrant 4. In these quadrants, motor torque is in the opposite direction of motor rotation.

This allows regenerative drives to reverse a motor without contactors or switches, to control an overhauling load, and to decelerate a load faster than it would take to coast to a lower speed.

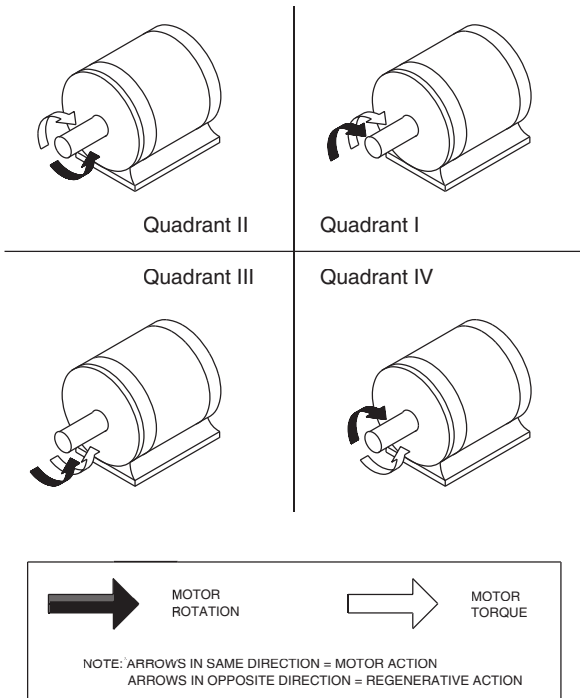

**Figure 1. Four Quadrant Operation**

# Specifications

| Maximum Model (Amps DC) | Armature Current Range | Armature Horsepower (Volts DC) | Voltage Range |
|-------------------------|------------------------|--------------------------------|---------------|
| MMRG30U, MMRG30U-PCM    | 5.0*                   | 1/8–1/2*                       | 0 – 90        |
| MMRG31U, MMRG31U-PCM    | 3.0                    | 1/20–1/8                       | 0 – 90        |
| MMRG40U, MMRG40U-PCM    | 5.0**                  | 1/4 - 1**                      | 0 – 180       |

\* Max. Armature Current = 10 ADC

Max. Horsepower = 1 hp when mounted to heat sink kit part number 223–0159.

\*\* Max. Armature Current = 10 ADC

Max. Horsepower = 2 hp when mounted to heat sink kit part number 223–0159.

## AC Line Voltage

|                      |  |
|----------------------|--|
| MMRG30U, MMRG30U-PCM | 115 VAC, $\pm 10\%$ , 50/60 Hz, single phase |
| MMRG31U, MMRG31U-PCM | 115 VAC, $\pm 10\%$ , 50/60 Hz, single phase |
| MMRG40U, MMRG40U-PCM | 230 VAC, $\pm 10\%$ , 50/60 Hz, single phase |

|  |  |
|--|--|
| Form Factor  | 1.37 at base speed                         |
| Acceleration Time Range  | 0.5 – 6 seconds                            |
| Deceleration Time Range  | 0.5 – 6 seconds                            |
| Analog Input Voltage Range (signal must be isolated; S1 to S2) | 0 $\pm$ 10 VDC                             |
| Input Impedance (S0 to S2)                                     | 30 kohms                                   |
| Load Regulation  | 1% base speed                              |
| Vibration  | 0.5G max. (20–50 Hz)<br>0.1G max. (>50 Hz) |
| Ambient Temperature Range                                      | 10°C–55°C                                  |
| Weight   | 1.1 lb                                     |

\* With the -PCM option, a drive can be configured to follow a grounded non-isolated voltage signal.



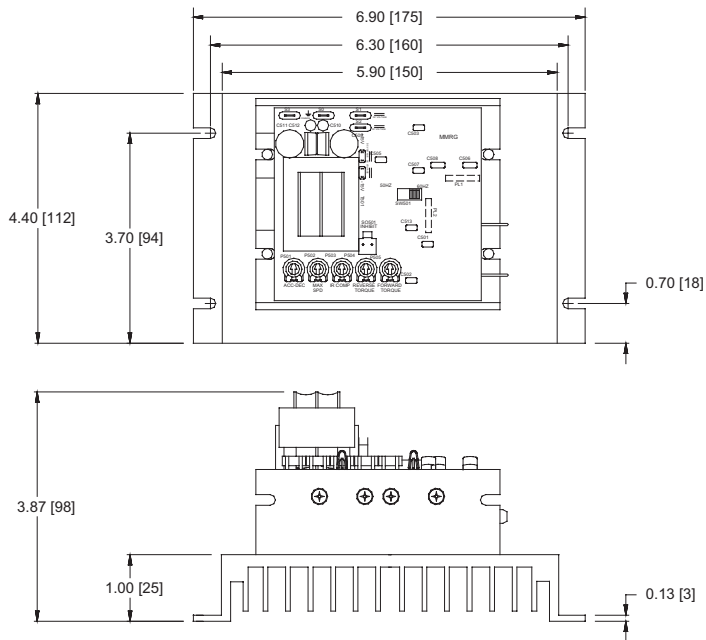

ALL DIMENSIONS IN INCHES [MILLIMETERS]  
MOUNTING SLOTS 0.19 X 3.4 [5 X 9]

**Figure 3. MMRG Dimensions**  
**(Drive mounted on 223–0159 heat sink kit)**

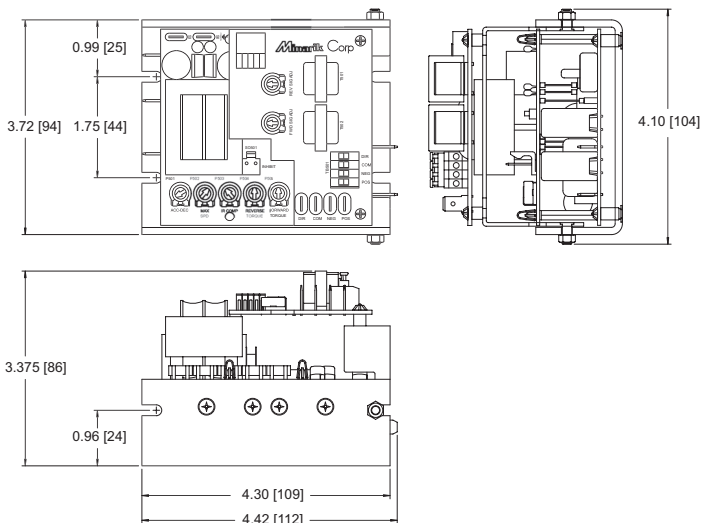

ALL DIMENSIONS IN INCHES [MILLIMETERS]  
 MOUNTING SLOTS 0.19 X 3.4 [5 X 9]

**Figure 4. MMRG-PCM Dimensions**

---

# Installation

## Mounting



### Warning

**Do not install, rewire, or remove this control with input power applied.** Doing so may cause fire or serious injury. Make sure you have read and understood the Safety Warnings on page i before attempting installation.

- Drive components are sensitive to electrostatic fields. Avoid direct contact with the circuit board. Hold drive by the chassis only.
- Protect the drive from dirt, moisture, and accidental contact.
- Provide sufficient room for access to the terminal block and calibration trimpots.
- Mount the drive away from heat sources. Operate the drive within the specified ambient operating temperature range.
- Prevent loose connections by avoiding excessive vibration of the drive.
- Mount drive with its board in either a horizontal or vertical plane. Six 0.19 in. (5 mm) wide slots in the chassis accept #8 pan head screws. Fasten either the large base or the narrow flange of the chassis to the subplate.
- The chassis must be earth grounded. Use a star washer beneath the head of at least one of the mounting screws to penetrate the anodized chassis surface and to reach bare metal.

## Wiring



### Warning



Do not install, remove, or rewire this equipment with power applied. Failure to heed this warning may result in fire, explosion, or serious injury.

Circuit potentials are at 115 or 230 VAC above ground. To prevent the risk of injury or fatality, avoid direct contact with the printed circuit board or with circuit elements.

Do not disconnect any of the motor leads from the drive unless power is removed and the drive is disabled. Opening any one motor lead may destroy the drive.

- Use 18 AWG wire for speed adjust potentiometer wiring. Use 16 AWG wire for field (F1, F2) wiring. Use 14 AWG wire for AC line (L1, L2) and motor (A1, A2) wiring.

## Shielding guidelines



### Warning

Under no circumstances should power and logic leads be bundled together. Induced voltage can cause unpredictable behavior in any electronic device, including motor controls.

As a general rule, Minarik recommends shielding of all conductors.

If it is not practical to shield power conductors, Minarik recommends shielding all logic-level leads. If shielding logic leads is not practical, the user should twist all logic leads with themselves to minimize induced noise.

It may be necessary to earth ground the shielded cable. If noise is produced by devices other than the drive, ground the shield at the drive end. If noise is generated by a device on the drive, ground the shield at the end away from the drive. Do not ground both ends of the shield.

If the drive continues to pick up noise after grounding the shield, it may be necessary to add AC line filtering devices, or to mount the drive in a less noisy environment.

Logic wires from other input devices, such as motion controllers and PLL velocity controllers, must be separated from power lines in the same manner as the logic I/O on this drive.

### **Heat sinking**

MMRG Series drives require an additional heat sink when the continuous armature current is above 5 ADC. Use Minarik heat sink kit part number 223-0159. Use a thermally conductive heat sink compound (such as Dow Corning® 340 Heat Sink compound) between the drive chassis and the heat sink surface for optimum heat transfer. Model MMRG31U does not require an additional heat sink.

## Speed adjust potentiometer



### Warning

Be sure that the potentiometer tabs do not make contact with the potentiometer enclosure. Grounding the input will cause damage to the drive.

Mount the speed adjust potentiometer through a 0.38 in. (10 mm) hole with the hardware provided (Figure 5). Install the circular insulating disk between the panel and the 10K ohm speed adjust potentiometer.

Twist the speed adjust potentiometer wire to avoid picking up unwanted electrical noise. If speed adjust potentiometer wires are longer than 18 in. (457 mm), use shielded cable. Keep speed adjust potentiometer wires separate from power leads (L1, L2, A1, A2).

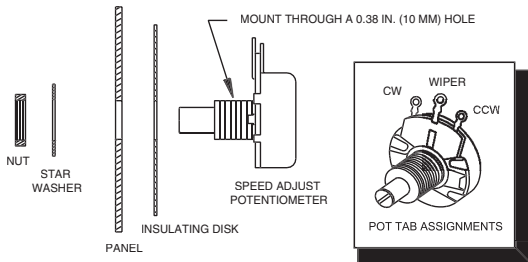

**Figure 5. Speed Adjust Potentiometer**

## Connections



### Warning

**Do not connect this equipment with power applied.**

Failure to heed this directive may result in fire or serious injury.

**Minarik strongly recommends the installation of a master power switch in the voltage input line, as shown in Figure 6, page 13.** The switch contacts should be rated at a minimum of 200% of motor nameplate current and 250 volts.

## Power, fuse and motor connections

Connect the power input leads, an external line fuse and a DC motor to the drive's printed circuit board (PCB) as shown in Figure 6, page 13.

## Motor

Minarik drives supply motor voltage from A1 and A2 terminals. It is assumed throughout this manual that, when A1 is positive with respect to A2, the motor will rotate clockwise (CW) while looking at the output shaft protruding from the front of the motor. If this is opposite of the desired rotation, simply reverse the wiring of A1 and A2 with each other.

Connect a DC motor armature to PCB terminals A1 and A2 as shown in Figure 6, page 13. **Ensure that the motor voltage rating is consistent with the drive's output voltage.**

## Power input

Connect the AC line power leads to terminals L1 and L2, or to a double-throw, single-pole master power switch (recommended).

## Line fuse

Minarik drives require fuses for protection. Use fast acting fuses rated for 250 VAC or higher, and approximately 150% of the maximum armature current. Fuse L1 only when the line voltage is 115 VAC. Fuse both L1 and L2 when the line voltage is 230 VAC.

Wire an external line fuse between the stop switch (if installed) and the terminal board. An additional line fuse should be installed on L2 if the input voltage is 230 VAC. Refer to the line fuse chart below for fuse ratings.

**Table 1. Recommended Line Fuse Sizes**

| 90 VDC Motor<br>Horsepower | 180 VDC Motor<br>Horsepower | Max. DC Armature<br>Current (amps) | AC Line Fuse<br>Size (amps) |
|----------------------------|-----------------------------|------------------------------------|-----------------------------|
| 1/20                       | 1/10                        | 0.5                                | 3                           |
| 1/15                       | 1/8                         | 0.8                                | 3                           |
| 1/8                        | 1/4                         | 1.5                                | 5                           |
| 1/6                        | 1/3                         | 1.7                                | 5                           |
| 1/4                        | 1/2                         | 2.5                                | 8                           |
| 1/3                        | 3/4                         | 3.5                                | 8                           |
| 1/2                        | 1                           | 5.0                                | 10                          |
| 3/4                        | 1 1/2                       | 7.5                                | 15                          |
| 1                          | 2                           | 10                                 | 20                          |

Minarik Corporation offers two fuse kits: part number 050-0069 (3-8A Fuse Kit) and 050-0073 (5-20A Fuse Kit). Both fuse kits include a 1/2A pico fuse (part number 050-0064) which protects the transformer and logic.

## MMRG BOTTOM BOARD

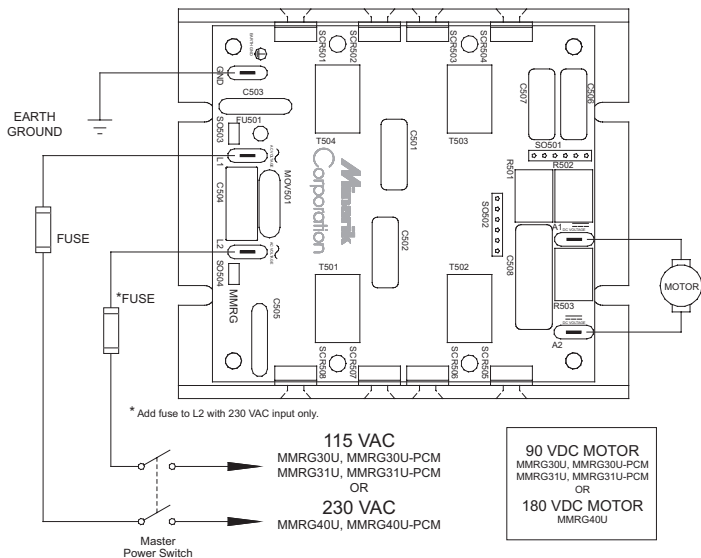
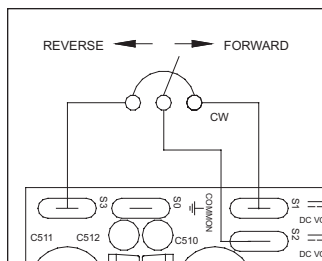
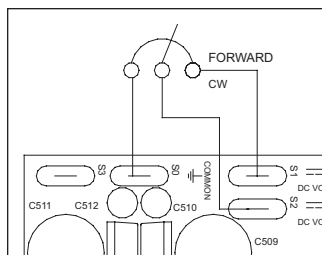
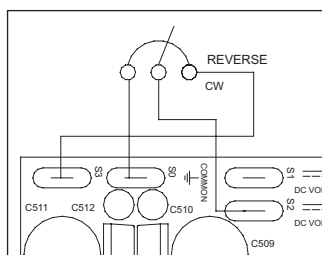

Figure 6. Power and Motor Connections



(a) Bidirectional Operation

(b) Unidirectional Operation,  
Forward Direction(c) Unidirectional Operation,  
Reverse Direction**Figure 7. Speed Adjust Potentiometer Connections**

## Voltage follower

The drive may be wired to follow a floating (isolated) 0 to  $\pm 10$ VDC signal that is isolated from earth ground instead of using a speed adjust potentiometer. Connect the signal input to S2, and the signal common to S0 (see Figure 8).

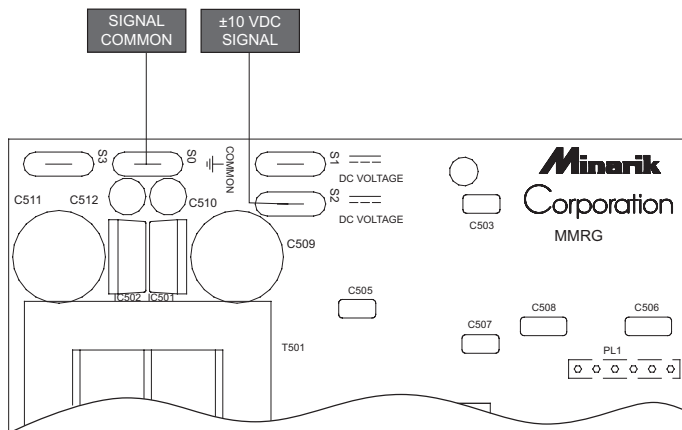

**Figure 8. Voltage Follower Connection**

## **Voltage follower (-PCM models)**

PCM series drives can be configured to follow a grounded (non-isolated) voltage signal. To configure the drive to follow a voltage signal, connect the signal leads to the SIGNAL INPUT POS and SIGNAL INPUT NEG terminals, observing proper polarity. Note: There are two locations where signal input connections can be made, either to terminals TB501 or to the fast-on terminal posts located below TB501. (see figure 9, page 17)

## **Polarity reversal switch (-PCM models)**

To reverse the output voltage polarity without changing the input polarity, connect DIR to COM. A single-pole, single-throw switch can be used as a polarity reversal switch. Close the switch to reverse the output voltage polarity. Open the switch to return the output voltage back to its original polarity. See Figure 9, page 17 for polarity reversal switch connections.

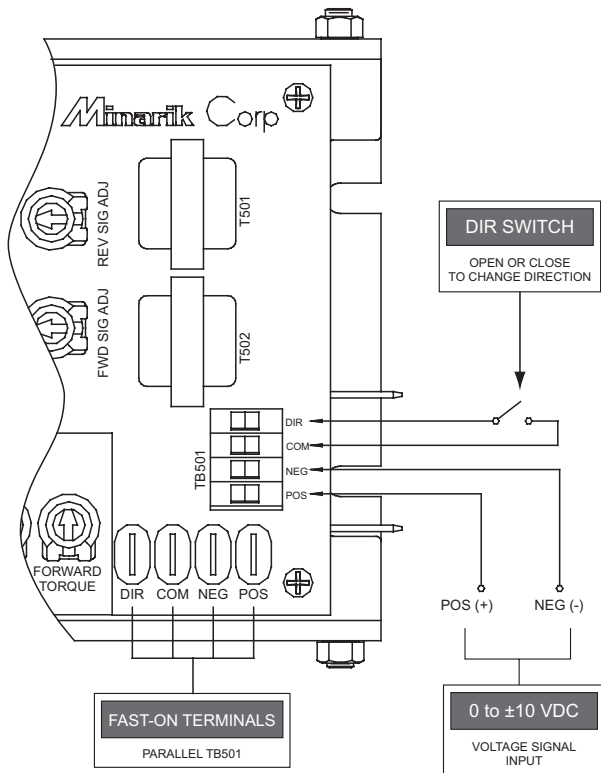

Figure 9. Voltage Follower Connection (-PCM Models)

## +15 and -15 terminals



### Warning

Do not short the +15 and -15 terminals for any reason. Shorting these terminals may damage the drive.

The MMRG Series drives can supply a regulated +15 and -15 VDC signal (each sourcing 15 mA maximum) to isolated, external devices. See Figure 10 for the voltage supply terminal locations.

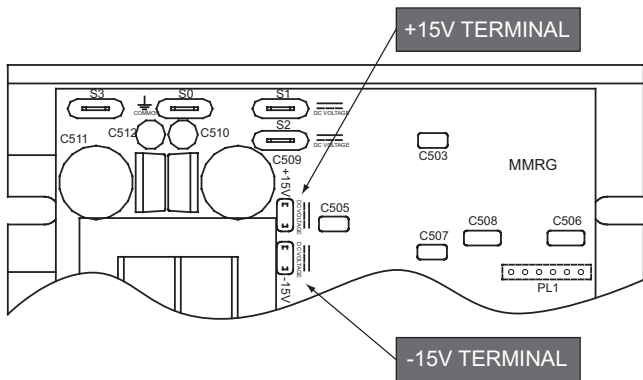
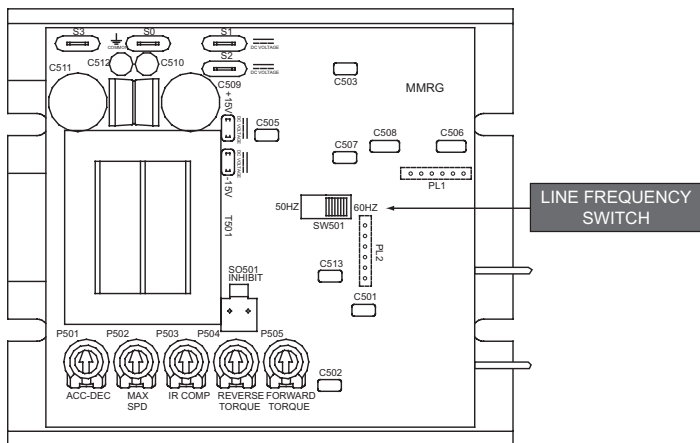

Figure 10. +15 and -15 Terminal Locations

## Line frequency switch

SW501 of the top board is the line frequency switch (see Figure 11). Set the switch to 50HZ if the line frequency is 50 Hz, or to 60HZ if the line frequency is 60 Hz.



**Figure 11. Line Frequency Switch**

# Operation



## Warning

Dangerous voltages exist on the drive when it is powered. BE ALERT. High voltages can cause serious or fatal injury. For your safety, use personal protective equipment (PPE) when operating this drive.

## Before applying power:

- Verify that no conductive material is present on the printed circuit board.
- Ensure that all jumpers are properly set.

## Startup and shutdown

### To start the drive:

1. Set the speed adjust potentiometer for zero speed, or the reference voltage to zero, if in voltage follower mode.
2. Apply AC line voltage.
3. Slowly turn the speed adjust potentiometer clockwise or counterclockwise to rotate the motor in the forward or reverse direction. If in voltage follower mode, increase reference voltage in the positive or negative direction. Continue until the desired speed is reached.
4. To decelerate the motor from set speed to a stop, reset the speed adjust potentiometer for zero speed. If in voltage follower mode, decrease reference voltage to zero. To coast the motor from set speed to a stop, remove AC line voltage from the drive.

If the motor or drive does not perform as described, disconnect the AC line voltage immediately. Refer to the Troubleshooting section for further assistance.

## Starting and Stopping Methods



### Warning

Decelerating to minimum speed, regenerative braking, or coasting to a stop is recommended for frequent starts and stops. Do not use any of these methods for emergency stopping. They may not stop a drive that is malfunctioning. Removing AC line power (both L1 and L2) is the only acceptable method for emergency stopping.

For this reason, **Minarik strongly recommends installing an emergency stop switch on both the L1 and L2 inputs** (see **Connections** section - page 11).

Frequent decelerating to minimum speed or regenerative braking produces high torque. This may cause damage to motors, especially gearmotors that are not properly sized for the application.

## Automatic restart upon power restoration

All drives automatically run to set speed when power is applied.

## Decelerate to a stop

The RUN/STOP switch in Figure 12 may be used to decelerate a motor to a stop. Closing the switch between S2 and S0 decelerates the motor from set speed to a stop. The ACC–DEC trimpot setting determines the rate at which the drive accelerates and decelerates. Set the switch to the RUN position to accelerate the motor to set speed.

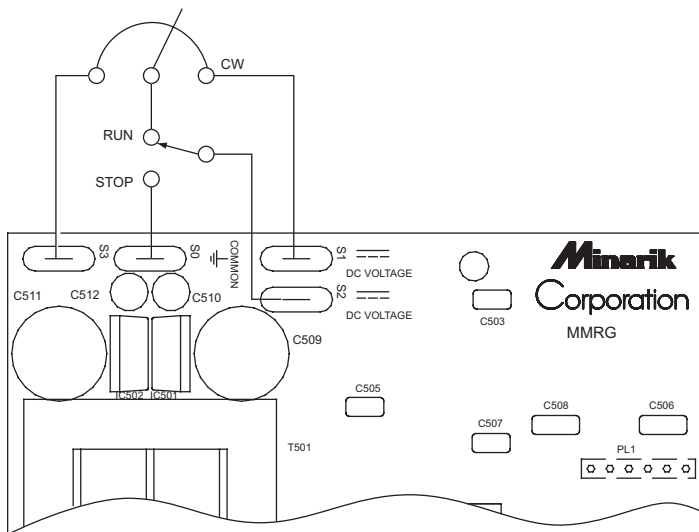

Figure 12. RUN/STOP Switch

## Regenerative brake

Short the INHIBIT terminals to regeneratively brake the motor (see Figure 13 for INHIBIT terminal location). Reopening the INHIBIT terminals causes the motor to accelerate to set speed.

Minarik Corporation offers two accessory plug harnesses for the INHIBIT terminals:

| <b>Minarik</b>     |  |
|--------------------|--|
| <b>Part Number</b> | <b>Description</b>                     |
| 201-0024           | Inhibit plug with 18 in. (46 cm) wires |
| 201-0079           | Inhibit plug with 36 in. (91 cm) wires |

Twist inhibit wires and separate them from other power-carrying wires or other sources of electrical noise. Use shielded cable if the inhibit wires are longer than 18 in. (46 cm). If shielded cable is used, ground only one end of the shield to earth ground. Do not ground both ends of the shield.

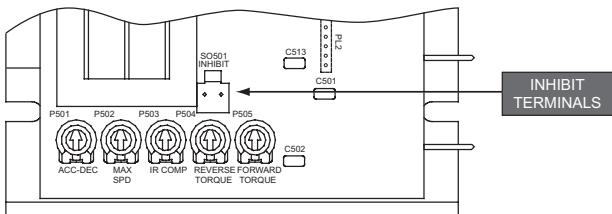

**Figure 13. INHIBIT Terminals**

# Calibration



## Warning

Dangerous voltages exist on the drive when it is powered. When possible, disconnect the voltage input from the drive before adjusting the trimpots. If the trimpots must be adjusted with power applied, use insulated tools and the appropriate personal protection equipment. **BE ALERT.** High voltages can cause serious or fatal injury.

MMRG Series drives have five user adjustable trimpots: MAX SPD, ACC-DEC, FORWARD TORQUE, REVERSE TORQUE, and IR COMP. MMRG-PCM series drives have two additional user adjustable trimpots: FWD SPD ADJ and REF SPD ADJ. Each drive is factory calibrated to its maximum current rating. Readjust the calibration trimpot settings to accommodate lower current rated motors. See Figure 14, page 26 for trimpot locations.

All adjustments increase with CW rotation, and decrease with CCW rotation. Use a non-metallic screwdriver for calibration. Each trimpot is identified on the printed circuit board.

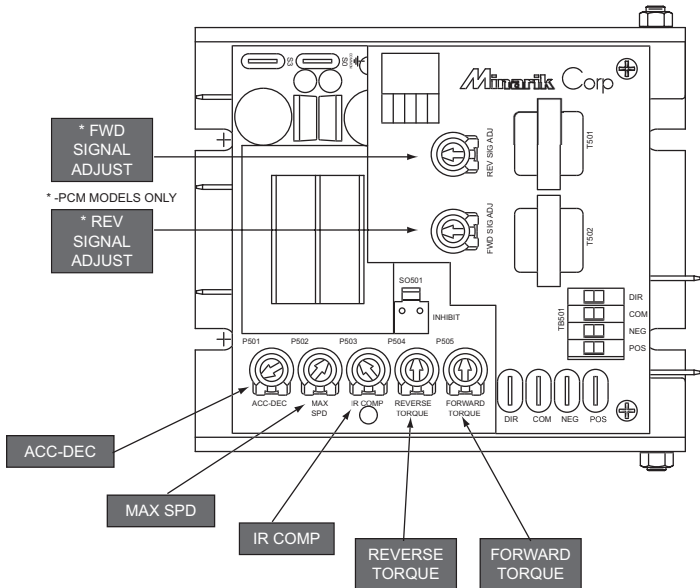

**Figure 14. Calibration Trimpot Layout**

## MAX SPD

The MAX SPD trimpot setting determines the maximum forward and reverse speed. It is factory set for maximum rated motor speed.

To calibrate MAX SPD:

1. Set the MAX SPD trimpot full CCW.
2. Turn the speed adjust potentiometer full CW.
3. Adjust the MAX SPD trimpot until the desired maximum motor speed is reached.

## FORWARD TORQUE



### Warning

Although FORWARD TORQUE can be set to 120% of drive nameplate current rating, continuous operation beyond this rating may damage the motor. If you intend to operate beyond this rating, contact your Minarik representative for assistance.

The FORWARD TORQUE setting determines the maximum current limit for driving the motor in the forward direction. It is factory set at 120% of maximum rated drive current. Refer to Figure 15 on page 33 for recommended settings or use the following procedure to recalibrate FORWARD TORQUE:

1. With the power disconnected from the drive, connect a DC ammeter in series with the armature.
2. Set the FORWARD TORQUE trimpot to minimum (full CCW).
3. Set the speed adjust potentiometer to maximum (full CW).
4. Carefully lock the motor armature. Be sure that the motor is firmly mounted.
5. Apply line power. The motor should be stopped.
6. Slowly adjust the FORWARD TORQUE trimpot CW slowly until the armature current is 120% of motor rated armature current.
7. Set the speed adjust potentiometer to minimum.
8. Remove the power from the drive and uncock the motor shaft.
9. Remove the ammeter in series with the motor armature if it is no longer needed and re-apply power to the drive.

## REVERSE TORQUE



### Warning

Although REVERSE TORQUE can be set to 120% of motor nameplate current rating, continuous operation beyond this rating may damage the motor. If you intend to operate beyond this rating, contact your Minarik representative for assistance.

The REVERSE TORQUE setting determines the maximum current limit for driving the motor in the reverse direction. It is factory set at 120% of maximum rated motor current. Refer to Figure 15 on page 33 for recommended settings or use the following procedure to recalibrate REVERSE TORQUE:

1. With the power disconnected from the drive, connect a DC ammeter in series with the armature.
2. Set the REVERSE TORQUE trimpot to minimum (full CCW).
3. Set the speed adjust potentiometer to maximum (full CW).
4. Carefully lock the motor armature. Be sure the motor is firmly mounted.
5. Apply line power. The motor should be stopped.
6. Slowly adjust the REVERSE TORQUE trimpot CW slowly until the armature current is 120% of motor rated armature current.
7. Set the speed adjust potentiometer to minimum.
8. Remove the power from the drive and unlock the motor shaft.
9. Remove the ammeter in series with the motor armature if it is no longer needed and re-apply power to the drive.

## IR COMP

The IR COMP trimpot setting determines the degree to which motor speed is held constant as the motor load changes. It is factory set for optimum motor regulation.

Refer to Figure 15 on page 33 for recommended settings or use the following procedure to recalibrate the IR COMP setting:

1. Set the IR COMP trimpot to minimum (full CW).
2. Rotate the speed adjust potentiometer until the motor runs at midspeed without load (for example, 900 RPM for an 1800 RPM motor). A hand held tachometer may be used to measure motor speed.
3. Load the motor armature to its full load armature current rating. The motor should slow down.
4. While keeping the load on the motor, rotate the IR COMP trimpot until the motor runs at the speed measured in step 2. If the motor oscillates (overcompensation), the IR COMP trimpot may be set too high (CW). Turn the IR COMP trimpot CCW to stabilize the motor.
5. Unload the motor.

## **ACC–DEC**

The ACC–DEC trimpot setting determines the time the motor takes to accelerate to a higher speed, or decelerate to a lower speed in the forward or reverse direction, within the limits of available torque. The ACC–DEC setting is factory set for its fastest forward acceleration and deceleration time (full CCW).

Turn the ACC–DEC trimpot CW to increase the acceleration and deceleration time, or CCW to decrease the acceleration and deceleration time.

## **FWD SIG ADJ (-PCM models)**

The FWD SIG ADJ setting determines the speed that the motor will achieve when the signal is at its maximum voltage. For MMRG30U-PCM and MMRG31U-PCM, it is factory-set to deliver a 90 VDC armature output with a 10 VDC input signal. For MMRG40U-PCM, it is factory-set to deliver a 180 VDC armature output with a 10 VDC input signal.

Adjust the FWD SIG ADJ trimpot when the motor is set to run in forward direction. To change this setting, apply the maximum voltage signal and rotate the FWD SIG ADJ trimpot until the desired motor speed is reached.

## **REV SIG ADJ (-PCM models)**

The REV SIG ADJ setting determines the speed that the motor will achieve when the signal is at its maximum voltage. For MMRG30U-PCM and MMRG31U-PCM, it is factory-set to deliver a 90 VDC armature output with a -10 VDC input signal. For MMRG40U-PCM, it is factory-set to deliver a 180 VDC armature output with a -10 VDC input signal.

Adjust the REV SIG ADJ trimpot when the motor is set to run in reverse direction. To change this setting, apply the maximum voltage signal and rotate the REV SIG ADJ trimpot until the desired motor speed is reached.

**MMRG31U**

1 HP  
90 VDC  
1750 RPM  
10 ADC

IR COMP  REVERSE TORQUE  FORWARD TORQUE 

3/4 HP  
90 VDC  
1750 RPM  
7.6 ADC

IR COMP  REVERSE TORQUE  FORWARD TORQUE 

1/2 HP  
90 VDC  
1750 RPM  
5 ADC

IR COMP  REVERSE TORQUE  FORWARD TORQUE 

**MMRG30U**

1/8 HP  
90 VDC  
1750 RPM  
1.3 ADC

IR COMP  REVERSE TORQUE  FORWARD TORQUE 

1/15 HP  
90 VDC  
1750 RPM  
0.85 ADC

IR COMP  REVERSE TORQUE  FORWARD TORQUE 

1/20 HP  
90 VDC  
1750 RPM  
0.56 ADC

IR COMP  REVERSE TORQUE  FORWARD TORQUE 

**MMRG40U**

2 HP  
180 VDC  
1750 RPM  
10 ADC

IR COMP  REVERSE TORQUE  FORWARD TORQUE 

1 HP  
180 VDC  
1750 RPM  
5 ADC

IR COMP  REVERSE TORQUE  FORWARD TORQUE 

3/4 HP  
180 VDC  
150 RPM  
3.8 ADC

IR COMP  REVERSE TORQUE  FORWARD TORQUE 

**Figure 15. Recommended IR COMP, REVERSE TORQUE, and FORWARD TORQUE Settings**

# Application Notes

## Connection to Minarik DLC600

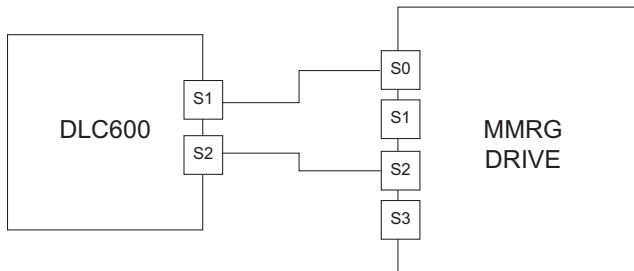

**Figure 16. MMRG Connection to DLC600**

## FWD-REV switch

Use a single-pole, two-position switch with a single speed adjust potentiometer to plug reverse the motor (Figure 17).

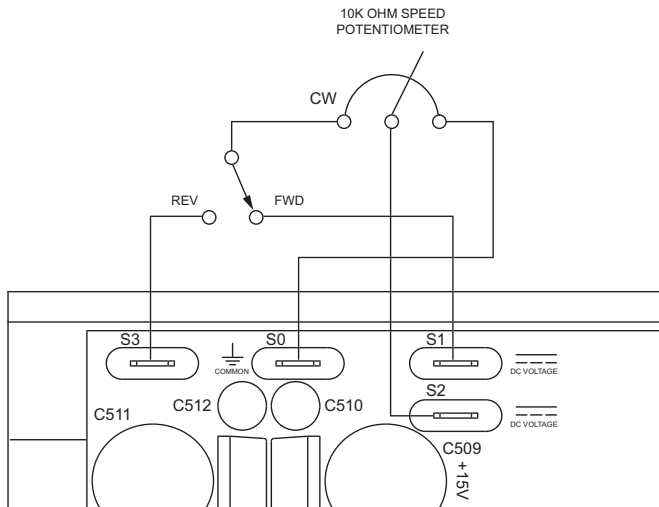
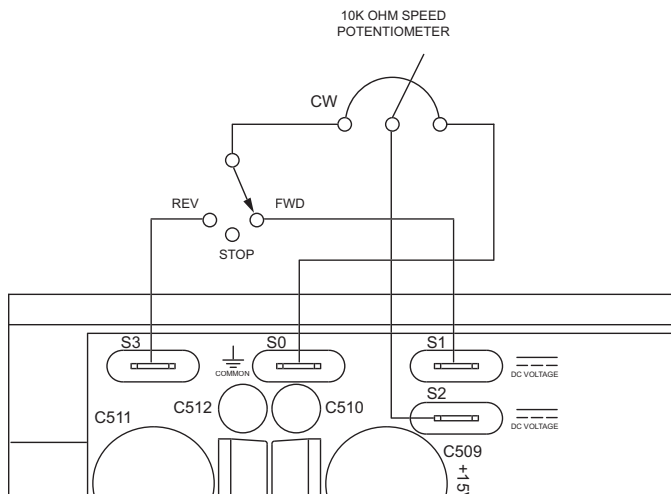

Figure 17. Forward-Reverse Switch

## FWD-STOP-REV switch

Use a single-pole, three-position switch with a single speed adjust potentiometer to stop a motor between reversal (Figure 18). Set the switch to the center position to decelerate the motor to a stop.



**Figure 18. Forward-Stop-Reverse Switch**

## Independent Adjustable Speeds

Connect two speed adjust potentiometers with a single-pole, two position switch to select between two independent speeds shown in the forward direction (Figure 19). The speed adjust potentiometers can be mounted at two separate operating stations.

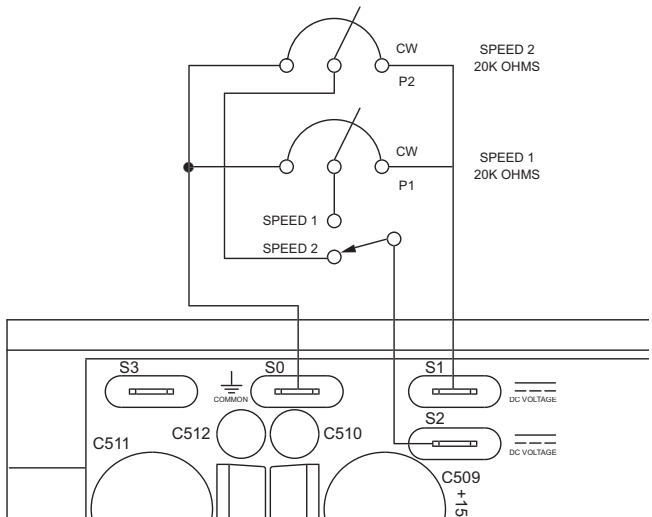
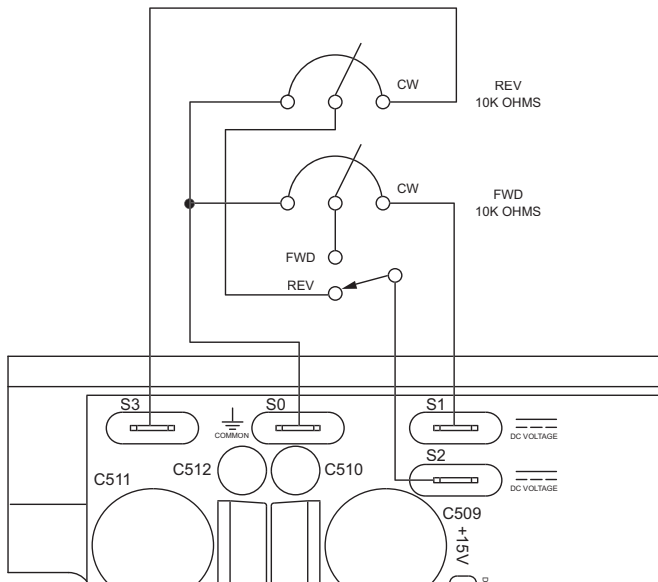

Figure 19. Independent Adjustable Speeds (Forward Direction)

## Independent forward and reverse speeds

Connect two speed adjust potentiometers as shown in Figure 20 to select between independent forward and reverse speeds.



**Figure 20. Independent Forward and Reverse Speeds**

## Independent forward and reverse speeds with FWD-STOP-REV switch

Use a single-pole, three-position switch to stop the motor when the switch is in the center position (Figure 21).

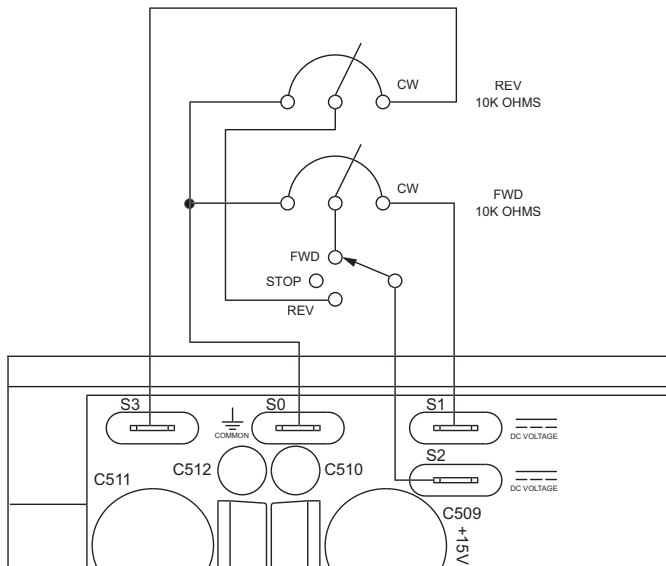

**Figure 21. Independent Forward and Reverse Speeds with a Forward-Stop-Reverse Switch**

# Troubleshooting



## Warning

Dangerous voltages exist on the drive when it is powered. When possible, disconnect the drive while troubleshooting. High voltages can cause serious or fatal injury.

## Before applying power

Check the following steps before proceeding:

1. The AC line voltage must be connected to the proper terminals.
2. Check that the voltage switches and jumpers are set correctly.
3. The motor must be rated for the drive's rated armature voltage and current.
4. Check that all terminal block connections are correct.

For additional assistance, contact your local Minarik distributor, or the factory direct:

1-800-MINARIK (646-2745) or Fax: 1-800-394-6334

| <b>Problem</b>   | <b>Possible Causes</b>  | <b>Suggested Solutions</b>  |
|------------------|---|---|
| Line fuse blows. | <ol style="list-style-type: none"><li data-bbox="387 221 584 271">1. Line fuse is the wrong size.</li><li data-bbox="387 326 627 402">2. Motor cable or armature is shorted to ground.</li><li data-bbox="387 431 621 613">3. Nuisance tripping caused by a combination of ambient conditions and high-current spikes (i.e. reversing).</li></ol> | <ol style="list-style-type: none"><li data-bbox="681 221 933 297">1. Check that the line fuse is correct for the motor size.</li><li data-bbox="681 326 907 402">2. Check motor cable and armature for shorts.</li><li data-bbox="681 431 943 771">3. Add a blower to cool the drive components; decrease FORWARD TORQUE and REVERSE TORQUE settings, <b>or</b> resize motor and drive for actual load demand, <b>or</b> check for incorrectly aligned mechanical components or “jams”.</li></ol> |

| <b>Problem</b>                                       | <b>Possible Causes</b>  | <b>Suggested Solutions</b>  |
|--|---|---|
| Line fuse does not blow, but the motor does not run. | <ol style="list-style-type: none"><li data-bbox="386 218 649 326">1. Speed adjust potentiometer or reference voltage is set to zero speed.</li><li data-bbox="386 359 649 550">2. Speed adjust potentiometer or reference voltage is not connected to drive input properly; connections are open.</li><li data-bbox="386 582 649 632">3. INHIBIT terminals are jumpered.</li><li data-bbox="386 692 649 715">4. S2 is shorted to S0.</li><li data-bbox="386 748 649 798">5. Drive is in current limit.</li><li data-bbox="386 997 649 1047">6. Drive is not receiving AC line voltage.</li><li data-bbox="386 1080 649 1130">7. Motor is not connected.</li></ol> | <ol style="list-style-type: none"><li data-bbox="674 218 947 326">1. Increase the speed adjust potentiometer setting or reference voltage.</li><li data-bbox="674 359 947 467">2. Check connections to input. Verify that connections are not open.</li><li data-bbox="674 582 947 659">3. Remove jumper from the INHIBIT terminals.</li><li data-bbox="674 692 947 715">4. Remove short.</li><li data-bbox="674 748 947 939">5. Verify that motor is not jammed. Increase FORWARD TORQUE or REVERSE TORQUE setting if they are set too low.</li><li data-bbox="674 997 947 1047">6. Apply AC line voltage to L1 and L2.</li><li data-bbox="674 1080 947 1130">7. Connect motor to A1 and A2.</li></ol> |

| <b>Problem</b>                          | <b>Possible Causes</b>  | <b>Suggested Solutions</b>  |
|---|---|---|
| Motor runs too fast.                    | 1. MAX SPD not calibrated.  | 1. Calibrate MAX SPD.   |
| Motor will not reach the desired speed. | 1. MAX SPD setting is too low.<br>2. IR COMP setting is too low.<br>3. Motor is overloaded. | 1. Increase MAX SPD setting.<br>2. Increase IR COMP setting.<br>3. Check motor load. Resize the motor and drive if necessary.   |
| Motor pulsates or surges under load.    | 1. IR COMP is set too high.<br>2. Motor bouncing in and out of current limit.               | 1. Adjust the IR COMP setting slightly CCW until the motor speed stabilizes.<br>2. Make sure motor is not undersized for load; adjust FORWARD TORQUE and REVERSE TORQUE trimpot CW. |
| Motor makes a humming or buzzing noise. | 1. Line frequency switch is set for wrong frequency.  | 1. Set line frequency switch for correct frequency.   |

## Replacement Parts

Replacement parts are available from Minarik Corporation and its distributors for this drive series.

**Table 2. Replacement Parts**

| <b>Model No.</b>     | <b>Symbol</b> | <b>Description</b>                     | <b>Minarik P/N</b>   |
|----------------------|---------------|--|----------------------|
| <b>MMRG30U</b>       | R503          | 0.01 ohm, 5 W Resistor                 | 032-0129             |
| <b>MMRG30U-PCM</b>   | SCR501-508    | 800 V, 25 A SCR                        | 072-0042             |
|                      | T501          | 3FS-436 Transformer                    | 230-0071             |
|                      |               | 10K ohm Potentiometer Kit<br>Chassis   | 202-0003<br>222-0191 |
| <b>MMRG31U</b>       | R503          | 0.1 ohm, 5 W Resistor                  | 032-0100             |
| <b>MMRG31U-PCM</b>   | SCR501-508    | 800 V, 25 A SCR                        | 072-0042             |
|                      | T501          | 3FS-436 Transformer                    | 230-0071             |
|                      |               | 10K ohm Potentiometer Kit<br>Chassis   | 202-0003<br>222-0191 |
| <b>MMRG40U</b>       | R503          | 0.01 ohm, 5 W Resistor                 | 032-0129             |
| <b>MMRG40U-PCM</b>   | SCR501-508    | 800 V, 25 A SCR                        | 072-0042             |
|                      | T501          | 3FD-436 Transformer                    | 230-0072             |
|                      |               | 10K ohm Potentiometer Kit<br>Chassis   | 202-0003<br>222-0191 |
| <b>Fuse Kits</b>     |               | 3-8A Fuse Kit                          | 050-0069             |
|                      |               | 5-20A Fuse Kit                         | 050-0073             |
|                      |               | 1/2A Pico Fuse                         | 050-0064             |
| <b>Inhibit Plugs</b> |               | Inhibit Plug with 18 in. (46 cm) wires | 201-0024             |
|                      |               | Inhibit Plug with 36 in. (91 cm) wires | 201-0079             |

---

# Certificate of Compliance

Minarik Corporation hereby certifies that its MMRG series drives has been approved to bear the “CE” mark provided the conditions of approval have been met by the end user.

The MMRG series has been tested to the following test specifications:

**EN55011:1991 (emissions), and  
EN50082-1:1992 (immunity)**

Compliance allows the MMRG series drives to bear the CE mark.

The end user, as described herein, falls into one of two categories:

1. The Consumer will deploy a stand-alone unit as an integral, yet external, portion of the machine being operated.
2. The Original Equipment Manufacturer (OEM) will implement the product as a component of the machine being manufactured.

## AC Line Filters

In addition to EMI/RFI safeguards inherent in the MMRG design, external filtering is required.

Minarik requires the Corcom<sup>®</sup> AC line filters listed in Table 3, as well as a line-to-line capacitor connected between L1 and L2. The capacitor must be rated at 2.2 microfarads and 250 volts minimum. Use model 5VV1 with drives rated for 3 ADC or below, and model 20VV1 with drives rated for 10 ADC or below.

**Table 3. AC Line Filters**

| <b>Corcom<sup>®</sup> Model Number</b> | <b>5VV1</b> | <b>20VV1</b> |
|--|-------------|--------------|
| Rated Current                          | 5 A         | 20 A         |
| Inductance                             | 1.032 mH    | 0.88 mH      |
| Capacitance                            |             |              |
| Line to Line                           | 0.303 mF    | 0.303 mF     |
| Line to Ground                         | 0.011 mF    | 0.011 mF     |
| Discharge Resistor                     | 680k ohms   | 680k ohms    |

Wire the AC line filter within 0.25 meters of the drive. The ground connection from the filter must be wired to solid earth ground (resistance less than 500 ohms); not machine ground. This is very important!

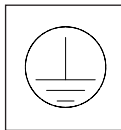

Use of a CE-approved motor, the correct filter from Table 3, in addition to the line-to-line capacitor, is all that is necessary to meet the EMC directives listed herein.

## Armature Filters

If the end-user is not using a CE-approved motor, a filter must also be used on the armature. See Table 4 for recommended armature filters. Use model CE4RG with drives rated for 3 ADC or below, and model CE20RG with drives rated for 10 ADC or below.

**Table 4. Armature Filters**

| <b>Minarik Model Number</b> | <b>CE4RG</b>      | <b>CE20RG</b> |
|-----------------------------|-------------------|---------------|
| Rated Current               | 4 A               | 20 A          |
| Inductance                  | 1200 mH           |               |
| Capacitance (C1 and C2)     | 0.1 mF @ 400W VDC |               |
| Discharge Resistor          | 680KOHMS          |               |

Wire the armature filter to the DC output of the drive, as close to the drive as possible. The ground connection from the filter must be wired to solid earth ground (resistance less than 500 ohms); not machine ground. This is very important!

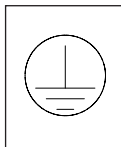

The end user must use the filtration listed in this addendum to comply with CE. The OEM may choose to provide alternative filtering that encompasses the Minarik drive and other electronics within the same panel. The OEM has this liberty because CE is a machinery directive.

Whether or not every component in the OEM's machinery meets CE, the OEM must still submit his machine for CE approval. Thus, no component must necessarily meet CE within the machine, as long as the OEM takes the necessary steps to guarantee the machine does meet CE. By the same token, even if every component in the OEM's machine does meet CE, the machine will not necessarily meet CE as a machine.

Using CE-approved wiring practices (like proper shielding) and the filters should assure the drive will meet EN55014 (1993 emissions standard) and EN50082-1 (1992 immunity standard).

---

## NOTES

## NOTES

# Unconditional Warranty

## A. Warranty

Minarik Corporation (referred to as "the Corporation") warrants that its products will be free from defects in workmanship and material for twelve (12) months or 3,000 hours, whichever comes first, from date of manufacture thereof. Within this warranty period, the Corporation will repair or replace, at its sole discretion, such products that are returned to Minarik Corporation, 901 East Thompson Avenue, Glendale, CA 91201-2011 USA.

This warranty applies only to standard catalog products, and does not apply to specials. Any returns for special controls will be evaluated on a case-by-case basis. The Corporation is not responsible for removal, installation, or any other incidental expenses incurred in shipping the product to and from the repair point.

## B. Disclaimer

The provisions of Paragraph A are the Corporation's sole obligation and exclude all other warranties of merchantability for use, express or implied. The Corporation further disclaims any responsibility whatsoever to the customer or to any other person for injury to the person or damage or loss of property of value caused by any product that has been subject to misuse, negligence, or accident, or misapplied or modified by unauthorized persons or improperly installed.

## C. Limitations of Liability

In the event of any claim for breach of any of the Corporation's obligations, whether express or implied, and particularly of any other claim or breach of warranty contained in Paragraph A, or of any other warranties, express or implied, or claim of liability that might, despite Paragraph B, be decided against the Corporation by lawful authority, the Corporation shall under no circumstances be liable for any consequential damages, losses, or expense arising in connection with the use of, or inability to use, the Corporation's product for any purpose whatsoever.

An adjustment made under warranty does not void the warranty, nor does it imply an extension of the original 12-month warranty period. Products serviced and/or parts replaced on a no-charge basis during the warranty period carry the unexpired portion of the original warranty only.

If for any reason any of the foregoing provisions shall be ineffective, the Corporation's liability for damages arising out of its manufacture or sale of equipment, or use thereof, whether such liability is based on warranty, contract, negligence, strict liability in tort, or otherwise, shall not in any event exceed the full purchase price of such equipment.

Any action against the Corporation based upon any liability or obligation arising hereunder or under any law applicable to the sale of equipment or the use thereof, must be commenced within one year after the cause of such action arises.



901 E Thompson Avenue  
Glendale, CA 91201-2011  
Tel.: 1-800-MINARIK (646-2745)  
Fax: 1-800-394-6334

[www.minarikcorp.com](http://www.minarikcorp.com)

Document number 250-0240, Revision 5  
Printed in the U.S.A – August 2002