

## XLA Series



Models:

XL1100A

XL3025A

XL3050A

XL3200A

Pulse-Width Modulated,  
Variable Speed DC Drives

User's Manual

Copyright © 2001 by Minarik Corporation

All rights reserved. No part of this manual may be reproduced or transmitted in any form without written permission from Minarik Corporation. The information and technical data in this manual are subject to change without notice. Minarik Corporation and its Divisions make no warranty of any kind with respect to this material, including, but not limited to, the implied warranties of its merchantability and fitness for a given purpose. Minarik Corporation and its Divisions assume no responsibility for any errors that may appear in this manual and make no commitment to update or to keep current the information in this manual.

Printed in the United States of America.

# Safety Warnings



- This symbol  denotes an important safety tip or warning. Failure to observe these warnings may result in serious injury. **Please read these instructions carefully** before performing any of the procedures contained in this manual.
- **DO NOT INSTALL, REMOVE, OR REWIRE THIS EQUIPMENT WITH POWER APPLIED.** Have a qualified electrical technician install, adjust and service this equipment. Follow the National Electrical Code and all other applicable electrical and safety codes, including the provisions of the Occupational Safety and Health Act (OSHA), when installing equipment.
- Reduce the chance of an electrical fire, shock, or explosion by proper grounding, over-current protection, thermal protection, and enclosure. Follow sound maintenance procedures.



**It is possible for a drive to run at full speed as a result of a component failure.** Minarik strongly recommends the installation of a master switch in the main power input to stop the drive in an emergency.

**Circuit potentials are at 115 VAC or 230 VAC above earth ground.** Avoid direct contact with the printed circuit board or with circuit elements to prevent the risk of serious injury or fatality. Use a non-metallic screwdriver for adjusting the calibration trimpots. Use approved personal protective equipment and insulated tools if working on this drive with power applied.

---

# Contents

<b>Specifications</b>	<b>1</b>
XL1100A .....	1
XL3025A .....	2
XL3050A .....	4
XL3200A .....	6
<b>Dimensions</b>	<b>8</b>
<b>Installation</b>	<b>10</b>
Drive mounting .....	10
Wiring .....	11
Shielding guidelines .....	12
Heat sinking .....	13
Fusing .....	13
Line Fusing for XL Series Drives .....	14
Speed adjust potentiometer mounting .....	15
Cage-clamp terminals .....	16
Connections .....	17
Motor connections .....	17
Power connections .....	18
External line fuse .....	18
Field output connections .....	20
Voltage follower connections .....	21
Voltage switches .....	22
<b>Operation</b>	<b>23</b>
Before applying power .....	23
Startup .....	24
Starting and Stopping Methods .....	25
Line starting and line stopping .....	25
Inhibit terminals .....	26
Decelerate to minimum speed .....	28

---

Dynamic braking	29
<b>Calibration</b>	<b>31</b>
Calibration procedure	33
MINIMUM SPEED (MIN SPD)	33
MAXIMUM SPEED (MAX SPD)	34
IR COMP	36
CURRENT LIMIT (CURR. LIMIT)	37
ACCELERATION (ACCEL)	38
DECELERATION (DECEL)	39
<b>Application Notes</b>	<b>41</b>
Multiple fixed speeds	41
Adjustable speeds using potentiometers in series	42
Independent adjustable speeds	43
RUN/JOG switch	44
RUN/JOG option #1	44
RUN/JOG option #2	45
Leader-follower application	46
Single speed potentiometer control of multiple drives	47
Reversing	48
Reversing with a DIGI-LOK® controller	49
<b>Troubleshooting</b>	<b>50</b>
Before troubleshooting	50
Diagnostic LEDs	51
POWER ON (IL501)	51
CURR LIM (IL502)	51
Replacement Parts	57
<b>Certificate of Compliance</b>	<b>59</b>
AC line filters	60
End User Responsibility	61
<b>Unconditional Warranty</b>	<b>inside back cover</b>

---

# Illustrations

Figure 1.	XLA Series Dimensions	.8
Figure 2.	Heat Sink Dimensions (p/n 223-0271)	.9
Figure 3.	Speed Adjust Potentiometer Installation	.15
Figure 4.	Cage-Clamp Terminal	.16
Figure 5.	XLA Series Connections	.19
Figure 6.	Voltage Follower Connections	.21
Figure 7.	Voltage Switches	.22
Figure 8.	Inhibit Terminals	.26
Figure 9.	Run/Decelerate to Minimum Speed Switch	.28
Figure 10.	Dynamic Brake Connection	.29
Figure 11.	Calibration Trimpot Layout	.32
Figure 12.	Low-Voltage DC Motor Calibration Settings	.35
Figure 13.	Typical CURRENT LIMIT and IR COMP settings	.40
Figure 14.	Multiple Fixed Speeds	.41
Figure 15.	Adjustable Speeds Using Potentiometers In Series	.42
Figure 16.	Independent Adjustable Speeds	.43
Figure 17.	RUN/JOG Switch (first wiring option)	.44
Figure 18.	RUN/JOG Switch (second wiring option)	.45
Figure 19.	Leader-follower application	.46
Figure 20.	Single Speed Potentiometer Control of Multiple Drives	.47
Figure 21.	Reversing Circuit Connection	.48
Figure 22.	Reversing with a DLC600	.49
Figure 23.	Diagnostic LED Location	.51
Figure 24.	CEXL Filter Connection to XLA Series Drive	.62

---

# Tables

Table 1.	Recommended Line Fuse Sizes .....	14
Table 2.	Field Output Connections .....	20
Table 3.	Inhibit Plug Harness Part Numbers .....	27
Table 4.	Minimum recommended dynamic brake resistor sizes .....	30
Table 5.	Replacement Parts .....	57
Table 6.	Minarik AC Line Filters .....	60

# Notes

# Specifications

## Model Number **XL1100A**

Type	open chassis	
AC Line Voltage	115 VAC, $\pm 10\%$ , 50/60 Hz, single phase	
Line Fuse Rating	15 A	
Horsepower Range	1/4–1 HP	
Form Factor	1.05	
Maximum Armature Current	5 ADC	
Maximum Armature Current with Heat Sink*	10 ADC	
Field Voltage @ 115 VAC Input	50 VDC/100 VDC	
Maximum Field Current	1 ADC	
Maximum Voltage Adjustment Range	50–150 VDC	
Minimum Voltage Adjustment Range	0–70 VDC	
Acceleration Time Range (with no load)	1–12 seconds	
Deceleration Time Range (with no load)	coast to a stop–12 seconds	
Speed Adjustment Potentiometer	10K ohms	
Analog Signal Voltage Range (signal must be isolated; S1 to S2)	0–2.7 VDC	
Approximate Input Impedance (from S1 to S2)	100K ohms	
Speed Regulation (at base speed)	1%	
Safety Certification	UL Recognized Component, file E132235 CSA Certified Component, file LR41380	
Power Device Switching Frequency	18 KHz	
Weight	1.4 lb	
Ambient Operating Temperature Range	10°C–40°C	

\*Use heat sink kit part number 223-0271 when continuous armature current is above 5 ADC.

**Model Number XL3025A**

Type	open chassis
AC Line Voltage	115 VAC/230 VAC, $\pm 10\%$ , 50/60 Hz, single phase
Line Fuse Rating	8 A
Horsepower Range @ 130 VDC Output	1/20–1/4 HP
Horsepower Range @ 240 VDC Output	1/8–1/3 HP
Form Factor	1.05
Maximum Armature Current	3 ADC
Field Voltage @ 115 VAC Input	50 VDC/100 VDC
Field Voltage @ 230 VAC Input	100 VDC/200 VDC
Maximum Field Current	1 ADC
Maximum Voltage Adjustment Range @ 115 VAC Input	60–150 VDC
Minimum Voltage Adjustment Range @ 115 VAC Input	0–70 VDC
Maximum Voltage Adjustment Range @ 230 VAC Input	60–240 VDC
Minimum Voltage Adjustment Range @ 230 VAC Input	0–70 VDC
Acceleration Time Range (with no load)	1–12 seconds
Deceleration Time Range (with no load)	coast to a stop–12 seconds
Speed Adjustment Potentiometer	10K ohms
Analog Signal Voltage Range (signal must be isolated; S1 to S2)	
for 0–130 VDC Armature Voltage	0–2.7 VDC
for 0–240 VDC Armature Voltage	0–5.0 VDC
Approximate Input Impedance (from S1 to S2)	100 Kohms
Speed Regulation (at base speed)	1%
Vibration	0.5G max (20–50 Hz) 0.1G max (>50 Hz)
Safety Certification	UL Recognized Component, file E132235 CSA Certified Component, file LR41380

---

Power Device Switching Frequency	18 KHz
Weight	1.4 lb
Ambient Operating Temperature Range	10°C–40°C

---

## Model Number **XL3050A**

Type	open chassis
AC Line Voltage	115 VAC/230 VAC, $\pm 10\%$ , 50/60 Hz, single phase
Line Fuse Rating	10 A
Horsepower Range @ 130 VDC Output	1/8–1/2 HP
Horsepower Range @ 240 VDC Output	1/4–3/4 HP
Form Factor	1.05
Maximum Armature Current	5 ADC
Field Voltage @ 115 VAC Input	50 VDC/100 VDC
Field Voltage @ 230 VAC Input	100 VDC/200 VDC
Maximum Field Current	1 ADC
Maximum Voltage Adjustment Range @ 115 VAC Input	55–150 VDC
Minimum Voltage Adjustment Range @ 115 VAC Input	0–65 VDC
Maximum Voltage Adjustment Range @ 230 VAC Input	55–240 VDC
Minimum Voltage Adjustment Range @ 230 VAC Input	0–65 VDC
Acceleration Time Range (with no load)	1–12 seconds
Deceleration Time Range (with no load)	coast to a stop–12 seconds
Speed Adjustment Potentiometer	10K ohms
Analog Signal Voltage Range (signal must be isolated; S1 to S2)	
for 0–130 VDC Armature Voltage	0–2.7 VDC
for 0–240 VDC Armature Voltage	0–5.0 VDC
Approximate Input Impedance (from S1 to S2)	100K ohms
Speed Regulation (at base speed)	1%
Vibration	0.5G max (20–50 Hz) 0.1G max (>50 Hz)
Safety Certification	UL Recognized Component, file E132235 CSA Certified Component, file LR41380

---

Power Device Switching Frequency	18 KHz
Weight	1.5 lb
Ambient Operating Temperature Range	10°C–40°C

---

## Model Number **XL3200A**

Type	open chassis
AC Line Voltage	115 VAC/230 VAC, $\pm 10\%$ , 50/60 Hz, single phase
Line Fuse Rating	15 A
Horsepower Range @ 130 VDC Output	1/4–1/2 HP
Horsepower Range @ 130 VDC Output with Heat Sink*	1/4–1 HP
Horsepower Range @ 240 VDC Output	1/2–1 HP
Horsepower Range @ 240 VDC Output with Heat Sink*	1/2–2 HP
Form Factor	1.05
Maximum Armature Current	5 ADC
Maximum Armature Current with Heat Sink*	9 ADC
Field Voltage @ 115 VAC Input	50 VDC/100 VDC
Field Voltage @ 230 VAC Input	100 VDC/200 VDC
Maximum Field Current	1 ADC
Maximum Voltage Adjustment Range @ 115 VAC Input	55–150 VDC
Minimum Speed Adjustment Range @ 115 VAC Input	0–65 VDC
Maximum Voltage Adjustment Range @ 230 VAC Input	55–240 VDC
Minimum Speed Adjustment Range @ 230 VAC Input	0–65 VDC
Acceleration Time Range (with no load)	1–12 seconds
Deceleration Time Range (with no load)	coast to a stop–12 seconds
Speed Adjustment Potentiometer	10K ohms
Analog Signal Voltage Range (signal must be isolated; S1 to S2)	
for 0–130 VDC Armature Voltage	0–2.7 VDC
for 0–240 VDC Armature Voltage	0–5.0 VDC
Approximate Input Impedance (from S1 to S2)	100K ohms
Speed Regulation (at base speed)	1%

---

Vibration	0.5G max (20–50 Hz) 0.1G max (>50 Hz)
-----------	--

---

Safety Certification	UL Recognized Component, file E132235 CSA Certified Component, file LR4138
----------------------	---

---

Power Device Switching Frequency	18 KHz
----------------------------------	--------

---

Weight	1.6 lb
--------	--------

---

Ambient Operating Temperature Range	10°C–40°C
-------------------------------------	-----------

---

\*Use heat sink kit part number 223-0271 or equivalent when continuous armature current is above 5 ADC.

---

# Dimensions

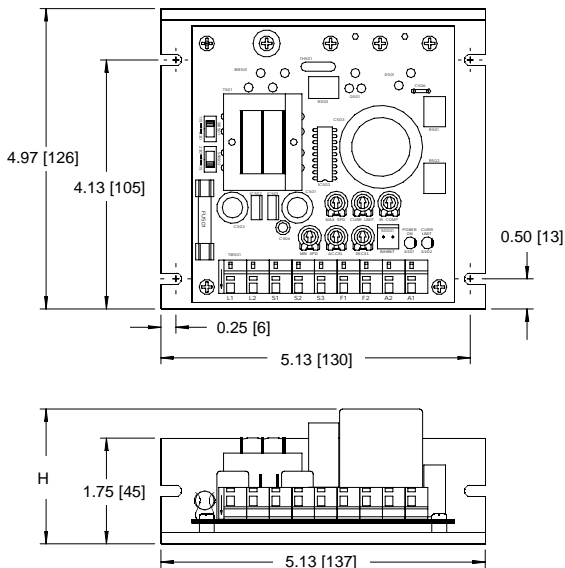

MODEL	DIM "H"
XL1100A	3.00 [76]
XL3025A	2.25 [57]
XL3050A	3.00 [76]
XL3200A	3.75 [95]

ALL DIMENSIONS IN INCHES [MILLIMETERS]

**Figure 1. XLA Series Dimensions**

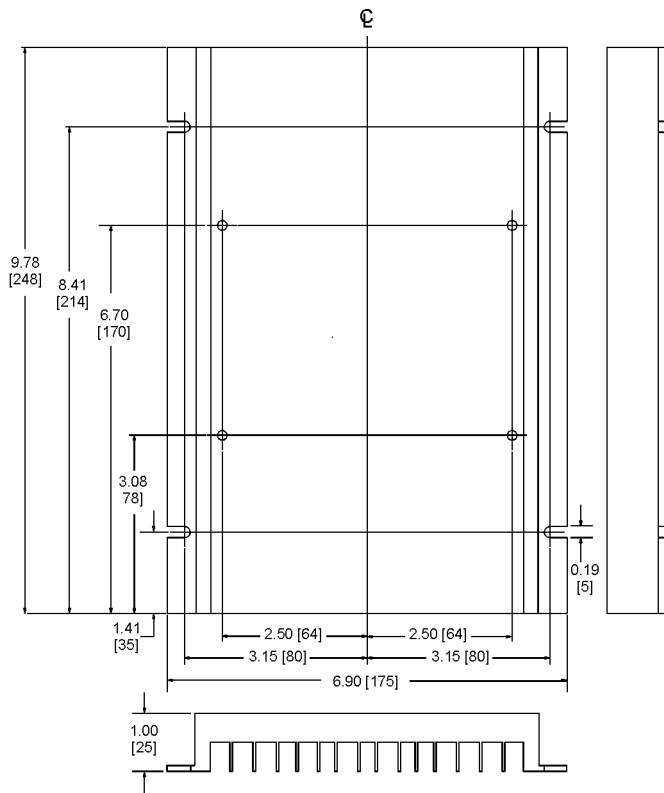

**Figure 2. Heat Sink Dimensions (p/n 223-0271)**

---

# Installation

## Drive mounting



### Warning

**Do not install, rewire, or remove this control with power applied.** Doing so may cause fire or serious injury. Make sure you have read and understood the Safety Warnings before attempting installation.

The chassis must be earth grounded. Use a star washer beneath the head of at least one of the mounting screws to penetrate the anodized chassis surface and to reach bare metal.

- Drive components are sensitive to electrostatic fields. Avoid direct contact with the circuit board. Hold drive by the chassis only.
- Protect the drive from dirt, moisture, and accidental contact. Provide sufficient room for access to the terminal block and calibration trimpots.
- Mount the drive away from heat sources. Operate the drive within the specified ambient operating temperature range.
- Prevent loose connections by avoiding excessive vibration of the drive.
- Mount the drive in either the horizontal or vertical plane. Six 0.19-in. (5 mm) wide slots in the chassis accept #8 panhead screws. Fasten with the large base or the narrow flange of the chassis to the subplate.

## Wiring



### Warning



**Do not install, remove, or rewire this equipment with power applied.** Failure to heed this warning may result in fire, explosion, or serious injury.

Circuit potentials are at 115 or 230 VAC above ground. To prevent the risk of injury or fatality, avoid direct contact with the printed circuit board or with circuit elements.

Do not disconnect any of the motor leads from the drive unless power is removed or the drive is disabled. Opening any one motor lead may destroy the drive.

Use 12 AWG wire for AC line voltage (L1 and L2) and motor armature (A1 and A2) wiring. Use 18 AWG wire for logic ( S1, S2, and S3) and motor field (F1 and F2) wiring.

## Shielding guidelines



### Warning

Under no circumstances should power and logic leads be bundled together. Induced voltage can cause unpredictable behavior in any electronic device, including motor controls.

As a general rule, Minarik recommends shielding of all conductors.

If it is not practical to shield power conductors, Minarik recommends shielding all logic-level leads. If shielding logic leads is not practical, the user should twist all logic leads with themselves to minimize induced noise.

It may be necessary to earth ground the shielded cable. If noise is produced by devices other than the drive, ground the shield at the drive end. If noise is generated by a device on the drive, ground the shield at the end away from the drive. Do not ground both ends of the shield.

If the drive continues to pick up noise after grounding the shield, it may be necessary to add AC line filtering devices, or to mount the drive in a less noisy environment.

## Heat sinking

XLA series models XL1100A and XL3200A require an additional heat sink (Minarik part number 223–0271) when the continuous armature current is above 5 ADC. All other XLA Series drives have sufficient heat sinking in their basic configuration. Use a thermally conductive heat sink compound (such as Dow Corning® 340 Heat Sink Compound) between the drive chassis and heat sink surface for optimum heat transfer.

## Fusing

**NOTE:** Model XL1100A drives do not require a line fuse on L2.

All XLA Series drives are fused for maximum rated current at 115 VAC line input. A factory installed fuse is connected to L1 (hot) of the AC line input. See *Replacement Parts* (page 57) for exact fuse size. For 230 VAC operation, add an additional line fuse for L2 (neutral). Use a 250 volt, fast-acting fuse rated at 150% of the maximum armature current. See Table 1 on page 14 for recommended sizes.

## Line Fusing for XL Series Drives

Minarik Corporation offers three fuse kits: part number 050-0068 (1-8A Fuse Kit), 050-0070 (3-10A Fuse Kit), and 050-0072 (5-15A Fuse Kit). All fuse kits include a 1/2A pico fuse (part number 050-0074) which protects the transformer and logic. Refer to Replacement Parts (page 57) for fuse kit contents.

**Table 1. Recommended Line Fuse Sizes**

<b>90 VDC Motor Horsepower</b>	<b>180 VDC Horsepower</b>	<b>Max. DC Armature Current (amps)</b>	<b>AC Line Fuse Size (amps)</b>
1/20	1/10	0.5	1
1/15	1/8	0.8	1.5
1/8	1/4	1.5	3
1/6	1/3	1.7	3
1/4	1/2	2.6	5
1/3	3/4	3.5	8
1/2	1	5.0	10
3/4	1 1/2	7.6	15
1	2	10	15

## Speed adjust potentiometer mounting



### Warning

Be sure that the potentiometer tabs do not make contact with the potentiometer enclosure. Grounding the input will cause damage to the drive.

Install the circular insulating disk between the mounting panel and the 10K ohm speed adjust potentiometer (see Figure 3). Mount the speed adjust potentiometer through a 0.38-inch (10 mm) hole with the hardware provided. Twist the speed adjust potentiometer wires to avoid picking up unwanted electrical noise.

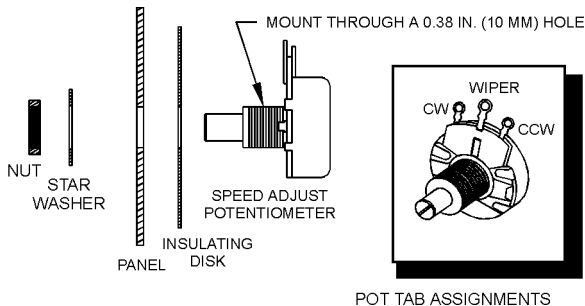

**Figure 3. Speed Adjust Potentiometer Installation**

## Cage-clamp terminals

XLA Series drive connections are of the cage-clamp terminal type (see Figure 4). To insert a wire into a terminal:

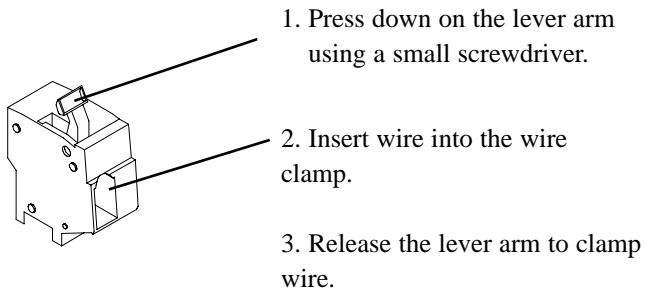

**Figure 4. Cage-Clamp Terminal**

## Connections



### Warning

**Do not connect this equipment with power applied.**

Failure to observe this precaution may result in fire or serious injury.

Minarik strongly recommends the installation of a master power switch in the voltage input line. The switch contacts should be rated at a minimum of 200% of motor nameplate current and 250 volts.

Connect the power input leads, an external line fuse (if required) and a DC motor to TB501 on the drive's printed circuit board (PCB) as shown in Figure 5 (page 19).

## Motor connections

Minarik drives supply motor voltage from A1 and A2 terminals. It is assumed throughout this manual that, when A1 is positive with respect to A2, the motor will rotate clockwise (CW) while looking at the output shaft protruding from the front of the motor. If this is opposite of the desired rotation, simply reverse the wiring of A1 and A2 with each other.

Connect a DC motor to TB501 terminals A1 and A2 as shown in Figure 5. **Ensure that the motor voltage rating is consistent with the drive's output voltage.**

## Power connections

Connect the AC line power leads to TB501 terminals L1 and L2, or to a double-throw, single-pole master power switch (recommended).

## External line fuse

**NOTE:** Model XL1100A drives do not require additional line fusing.

An additional line fuse should be installed on L2 if the input voltage is 230 VAC. The line fuse should be rated at 250 volts and 150 - 200% of maximum motor nameplate current. Refer to the line fuse chart on page 14 for fuse ratings.

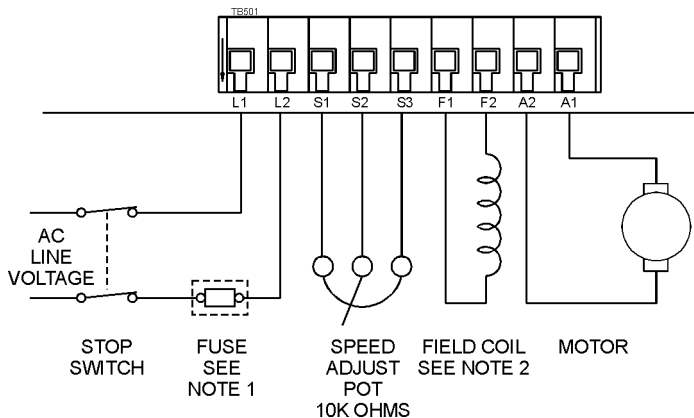
**NOTES:**

- DO NOT ADD LINE FUSE TO L2 IF USING MODEL XL1100A DRIVES. ADD LINE FUSE TO L2 FOR ALL OTHER DRIVES IF LINE VOLTAGE IS 230 VAC.
- DO NOT CONNECT FIELD CIRCUIT IF USING A PERMANENT-MAGNET MOTOR. REFER TO TABLE 2 (PAGE 20) FOR ALTERNATE FIELD CONNECTIONS.

**Figure 5. XLA Series Connections**

---

## Field output connections



### Warning

The field output is for shunt wound motors only. Do not make any connections to the field output when using a permanent magnet motor.

Use 18 AWG wire for field connections. See Table 2 for field output connections.

**Table 2. Field Output Connections**

<b>Line Voltage (VAC)</b>	<b>Approximate Field Voltage (VDC)</b>	<b>Field Connections</b>
115	50	F1 and L1
115	100	F1 and F2
230	100	F1 and L1
230	200	F1 and F2

## Voltage follower connections

Instead of using a speed adjust potentiometer, the drive may be wired to follow a voltage signal that is isolated from earth ground (Figure 6). Use an analog voltage range of 0 - 2.7 VDC with 115 VAC line voltage. Use an analog voltage range of 0 - 5 VDC with 230 VAC line voltage.

Connect the signal input (+) to S2. Connect the signal common (-) to S1. Make no connection to S3. A potentiometer can be used to scale the analog input voltage. To achieve greater linearity and control, use an interface device such as Minarik model PCM4 to scale the analog input voltage. Follow the same wiring guidelines used for speed adjust potentiometer wiring.

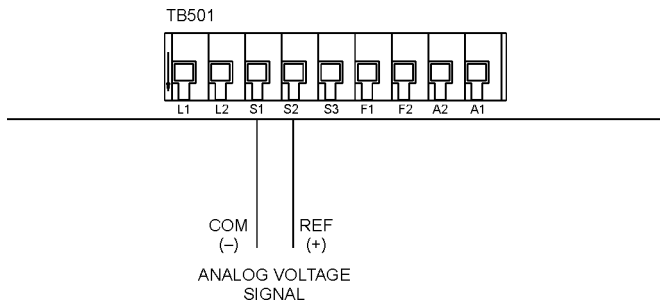

**Figure 6. Voltage Follower Connections**

## Voltage switches



### Warning

Change switch settings only when the drive is disconnected from AC line voltage. Make sure both switches are set to their correct positions. If the switches are improperly set to a lower voltage position, the motor will not run at full voltage. If the switches are improperly set to a higher voltage position, the motor will overspeed, which may cause motor damage.

**NOTE:** Model XL1100A does not include these switches.

Two voltage switches (SW501 and SW502) must be set to either 115 or 230 to match the AC line voltage being used. See Figure 7 for the location of the voltage switches.

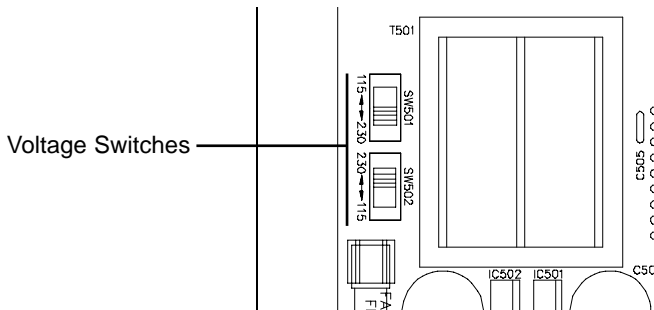

Figure 7. Voltage Switches

---

# Operation



## Warning

Dangerous voltages exist on the drive when it is powered, and up to 30 seconds after power is removed and the motor stops. **BE ALERT.** High voltages can cause serious or fatal injury.

Change switch settings only when the drive is disconnected from AC line voltage. Make sure both switches are set to their correct positions. If the switches are improperly set to a lower voltage position, the motor will not run at full voltage. If the switches are improperly set to a higher voltage position, the motor will overspeed, which may cause motor damage.

## Before applying power

1. Verify that no conductive material is present on the printed circuit board.
2. Set all switches to their proper settings, if required.
3. Verify that the AC supply is properly balanced.

## Startup

1. Turn the speed adjust potentiometer full counterclockwise (CCW). If the drive is following a voltage signal, set the voltage signal to 0 VDC.
2. Apply AC line voltage.
3. Slowly advance the speed adjust potentiometer clockwise (CW). If a voltage signal is used, slowly increase the voltage signal. The motor slowly accelerates as the potentiometer is turned CW, or the voltage signal is increased. Continue until the desired speed is reached.
4. To stop the drive, set the speed adjust potentiometer or voltage signal to zero.

## Starting and Stopping Methods



### Warning

For frequent starts and stops, use dynamic braking, inhibit mode, or decelerating to minimum speed (shorting S2 to S1). Do not use any of these methods for emergency stopping. They may not stop a drive that is malfunctioning. Removing AC line power (both L1 and L2) is the only acceptable method for emergency stopping.

For this reason, Minarik strongly recommends the installation of an emergency stop switch. The switch contacts should be rated at a minimum of 250 volts and 200% of maximum motor current.

### Line starting and line stopping

When AC line voltage is applied to the drive, the motor accelerates to the set speed. When AC line voltage is removed, the motor coasts to a stop. Line stopping (removing AC line voltage) is not necessary, and therefore not recommended for stopping except for emergency situations.

## Inhibit terminals

Jumper the INHIBIT terminals to coast the motor to a stop (see Figure 8). Remove the jumper to accelerate the motor to set speed.

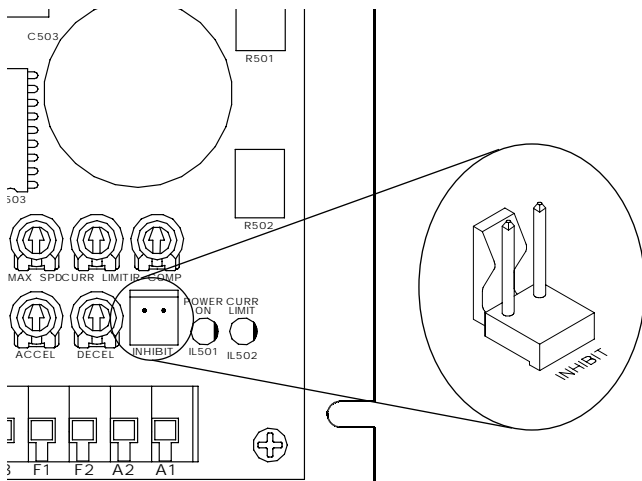

**Figure 8. Inhibit Terminals**

## Inhibit plug

Minarik Corporation offers two accessory plug harnesses for use with the INHIBIT terminals:

**Table 3. Inhibit Plug Harness Part Numbers**

<b>Minarik Part Number</b>	<b>Description</b>
201-0024	Inhibit plug with 18 in. (46 cm) wires
201-0079	Inhibit plug with 36 in. (91 cm) wires

Twist inhibit plug wires and separate them from other power-carrying wires or sources of electrical noise. Use shielded cable if the inhibit plug wires are longer than 12 inches (30 cm). If shielded cable is used, ground only one end of the shield to earth ground. Do not ground both ends of the shield. See *Wiring*, page 11, for more wiring information.

## Decelerate to minimum speed

The circuit shown in Figure 9 may be used to decelerate a motor to a minimum speed. Closing the switch between S2 and S1 decelerates the motor from set speed to a minimum speed determined by the MIN SPD trimpot setting. If the MIN SPD trimpot is set full CCW, the motor decelerates to zero speed when the switch between S2 and S1 is closed. Calibrate the ACCEL and DECEL trimpots to control the acceleration and deceleration ramp. Set the switch to the RUN position to accelerate the motor to set speed.

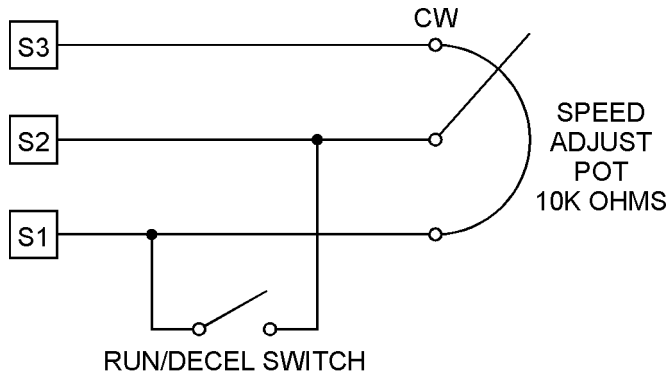

Figure 9. Run/Decelerate to Minimum Speed Switch

## Dynamic braking

Dynamic braking may be used to rapidly stop a motor (see Figure 10). For the RUN/BRAKE switch, use a two pole, two position switch rated to handle the motor voltage and current. For the dynamic brake resistor, use a high power, wirewound resistor (minimum 40 watts). Table 4 (page 30) lists the minimum recommended dynamic brake resistor values.

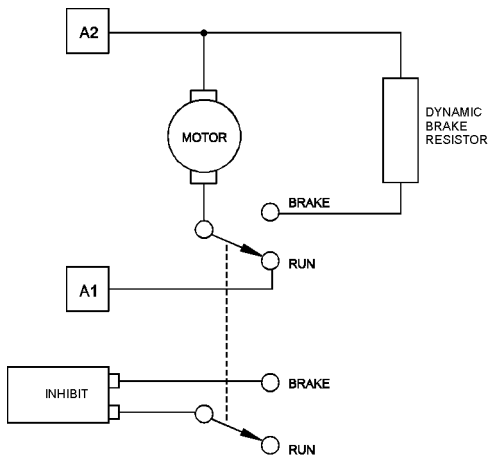

Figure 10. Dynamic Brake Connection

### **Sizing the dynamic brake resistor**

Sizing the dynamic brake resistor depends on load inertia, motor voltage, and braking time. Use a lower ohm value, higher wattage, dynamic brake resistor to stop a motor more rapidly. Refer to Table 4 below for minimum recommended dynamic brake resistor sizes.

**Table 4. Minimum recommended dynamic brake resistor sizes**

<b>Motor Voltage (VDC)</b>	<b>Minimum Recommended Dynamic Brake Resistor Size (ohms)</b>
90	15
130	22
180	30
240	40

---

# Calibration



## Warning

Dangerous voltages exist on the drive when it is powered, and up to 30 seconds after power is removed and the motor stops. When possible, disconnect the voltage input from the drive before adjusting the trimpots. If the trimpots must be adjusted with power applied, use insulated tools and the appropriate personal protection equipment. **BE ALERT.** High voltages can cause serious or fatal injury.

XLA Series drives have six user-adjustable trimpots: MAX SPD, MIN SPD, ACCEL, DECEL, IR COMP, and CURR. LIMIT. All trimpots are factory calibrated (see Figure 13, page 40, for factory CURR. LIMIT and IR COMP settings).

All adjustments increase with CW rotation and decrease with CCW rotation. Use a non-metallic screwdriver for calibration. Each trimpot is identified on the printed circuit board. Refer to Figure 11, page 32, for trimpot location.

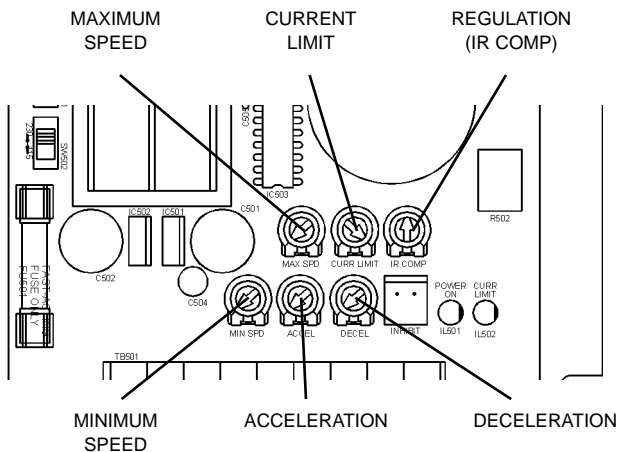

**Figure 11. Calibration Trimpot Layout**

## Calibration procedure

Calibrate the drive using the following procedure:

1. Set the MIN SPD, MAX SPD, ACCEL and DECEL trim pots to zero (full CCW).
2. Set the CURRENT LIMIT trim pot to maximum (full CW).
3. Set the IR COMP trim pot to midrange (approximate 12 o'clock position).
4. Set the signal input (analog voltage signal or speed adjust potentiometer) to zero.
5. Apply power to the drive.
6. Calibrate the trim pots as follows:

### **MINIMUM SPEED (MIN SPD)**

The MIN SPD setting determines the motor speed when the speed adjust potentiometer is turned full CCW. It is factory set for minimum rated speed.

To calibrate, set the MIN SPD trim pot full CCW. Set the speed adjust potentiometer or reference signal to zero speed. Adjust the MIN SPD trim pot until the desired minimum motor speed is reached.

## MAXIMUM SPEED (MAX SPD)

The MAX SPD setting determines the motor speed when the speed adjust potentiometer is turned full CW. It is factory set for maximum rated speed.







To calibrate, set the MAX SPD trimpot full CCW. Set the speed adjust potentiometer or reference signal to maximum. Adjust the MAX SPD trimpot until the desired maximum motor speed is reached.

### **MAX SPD calibration with low voltage DC motors**

Using an XLA series drive with a low voltage DC motor requires that a lower resistance speed adjust potentiometer be used.

Recalibrate the MAX SPD trimpot setting to the positions shown in Figure 12.

**Note:** MAX SPD settings are approximate. Verify maximum armature voltage with a voltmeter.

MOTOR ARMATURE VOLTAGE (VDC)	MAX SPEED TRIMPOT SETTING	
	USING 2.5K OHM SPEED ADJUST POTENTIOMETER	USING 1.5K OHM SPEED ADJUST POTENTIOMETER
12	NOT APPLICABLE	
24		
36		
48		

**Figure 12. Low-Voltage DC Motor Calibration Settings**

## IR COMP

The IR COMP trimpot setting determines the degree to which motor speed is held constant as the motor load changes. It is factory set for optimum motor regulation. Refer to Figure 13 (page 40) for typical CURR. LIMIT and IR COMP settings.

To calibrate IR COMP (exact calibration):

1. Turn the IR COMP trimpot full CCW.
2. Set the speed adjust potentiometer or reference signal until the motor runs at midspeed without load (for example, 900 RPM for an 1800 RPM motor) A hand held tachometer may be used to measure motor speed.
3. Load the motor armature to its full load armature current rating. The motor should slow down.
4. While keeping the load on the motor, rotate the IR COMP trimpot until the motor runs at the speed measured in step 2.

## CURRENT LIMIT (CURR. LIMIT)



### Warning

Although CURRENT LIMIT is set to 120% of maximum drive current rating, continuous operation beyond that rating may damage the motor. If you intend to operate beyond the rating, contact your Minarik representative for assistance.

The CURRENT LIMIT setting determines the maximum torque for accelerating and driving the motor. CURRENT LIMIT is factory set at 120% of maximum drive current. You must recalibrate the CURR. LIMIT setting if using a lower current motor. Refer to Figure 13 (page 40) for typical CURR. LIMIT and IR COMP settings.

1. With no power applied to the drive, connect a DC ammeter in series with the motor armature.
2. Set the CURR. LIMIT trimpot to full CCW.
3. Carefully lock the motor armature. Ensure that the motor is firmly mounted.
4. Apply line power. The motor should be stopped.
5. Set the speed potentiometer or reference signal to maximum speed. The motor should remain stopped.
6. Slowly rotate the CURR. LIMIT trimpot clockwise (CW) until the ammeter reads 120% of maximum motor armature current.
7. Set the speed adjust potentiometer or reference signal to zero speed.

8. Remove power from the drive.
9. Remove the lock from the motor shaft.
10. Remove the ammeter in series with the motor armature.

## **ACCELERATION (ACCEL)**

The ACCEL setting determines the time the motor takes to ramp to a higher speed. See *Specifications* on page 1 for approximate acceleration times. ACCEL is factory set for the fastest acceleration time (full CCW).

To set the acceleration time:

1. Set the speed adjust potentiometer full CCW. The motor should run at minimum speed.
2. Turn the speed adjust potentiometer full CW and measure the time it takes the motor to go from minimum to maximum speed.
3. If the time measured in step 2 is not the desired acceleration time, turn the ACCEL trimpot CW for a slower acceleration time, or CCW for a faster acceleration time. Repeat steps 1 through 3 until the acceleration time is correct

## DECELERATION (DECEL)

The DECEL setting determines the time the motor takes to ramp to a lower speed. See *Specifications* on page 1 for approximate deceleration times. DECEL is factory set for the fastest deceleration time (full CCW).













To set the deceleration time:

1. Set the speed adjust potentiometer full CW. The motor should run at maximum speed.
2. Turn the speed adjust potentiometer full CCW and measure the time it takes the motor to go from maximum to minimum speed.
3. If the time measured in step 2 is not the desired deceleration time, turn the DECEL trimpot CW for a slower deceleration time, or CCW for a faster deceleration time. Repeat steps 1 through 3 until the deceleration time is correct.













## XL1100

		1/4 HP 90 VDC 1750 RPM 2.5 AMPS			1 HP 90 VDC 1750 RPM 10 AMPS
CURR LIMIT	IR COMP		CURR LIMIT	IR COMP	













## XL3025A

		1/20 HP 90 VDC 1750 RPM 0.5 AMPS			1/8 HP 180 VDC 1750 RPM 0.67 AMPS
CURR LIMIT	IR COMP		CURR LIMIT	IR COMP	
		1/8 HP 90 VDC 1750 RPM 1.3 AMPS			1/4 HP 180 VDC 1750 RPM 1.4 AMPS
CURR LIMIT	IR COMP		CURR LIMIT	IR COMP	
		1/4 HP 90 VDC 1750 RPM 2.5 AMPS			1/3 HP 180 VDC 1750 RPM 1.75 AMPS
CURR LIMIT	IR COMP		CURR LIMIT	IR COMP	

## XL3050A

		1/8 HP 90 VDC 1750 RPM 1.3 AMPS			1/4 HP 180 VDC 1750 RPM 1.4 AMPS
CURR LIMIT	IR COMP		CURR LIMIT	IR COMP	
		1/4 HP 90 VDC 1750 RPM 2.5 AMPS			1/2 HP 180 VDC 1750 RPM 2.5 AMPS
CURR LIMIT	IR COMP		CURR LIMIT	IR COMP	
		1/2 HP 90 VDC 1750 RPM 5 AMPS			3/4 HP 180 VDC 1750 RPM 3.8 AMPS
CURR LIMIT	IR COMP		CURR LIMIT	IR COMP	

## XL3200A

		1/4 HP 90 VDC 1750 RPM 2.5 AMPS			1/2 HP 180 VDC 1750 RPM 2.5 AMPS
CURR LIMIT	IR COMP		CURR LIMIT	IR COMP	
		1/2 HP 90 VDC 1750 RPM 5 AMPS			1 HP 180 VDC 1750 RPM 5 AMPS
CURR LIMIT	IR COMP		CURR LIMIT	IR COMP	
		1 HP 90 VDC 1750 RPM 10 AMPS			2 HP 180 VDC 1750 RPM 10 AMPS
CURR LIMIT	IR COMP		CURR LIMIT	IR COMP	

**Figure 13. Typical CURR. LIMIT and IR COMP settings (actual settings may vary)**

# Application Notes

## Multiple fixed speeds

Replace the speed adjust potentiometer with series resistors with a total series resistance of 10K ohms (see Figure 14). Add a single pole, multi-position switch with the correct number of positions for the desired number of fixed speeds.

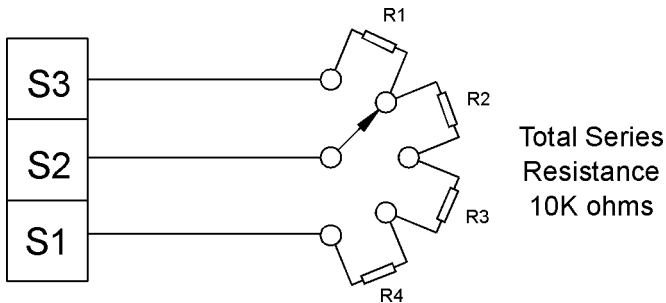

Figure 14. Multiple Fixed Speeds

## Adjustable speeds using potentiometers in series

Replace the speed adjust potentiometer with a single pole, multi-position switch, and two or more potentiometers in series, with a total series resistance of 10K ohms. Figure 15 shows the connection for two speed control with high and low speed adjust potentiometers.

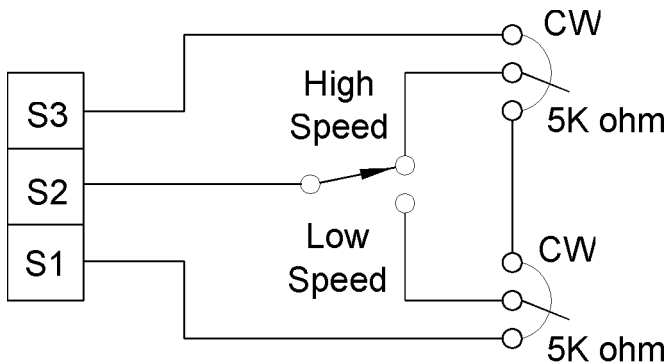

Figure 15. Adjustable Speeds Using Potentiometers In Series

## Independent adjustable speeds

Replace the speed adjust potentiometer with a single pole, multi-position switch, and two or more potentiometers in parallel, with a total parallel resistance of 10K ohms. Figure 16 shows the connection of two independent speed adjust potentiometers that can be mounted at two separate operating stations.

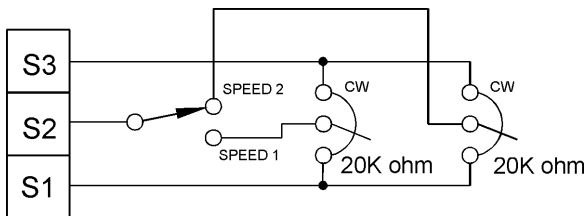

Figure 16. Independent Adjustable Speeds

## RUN/JOG switch

Using a RUN/JOG switch is recommended in applications where quick stopping is not needed and frequent jogging is required.

Use a single pole, two position switch for the RUN/JOG switch, and a single pole, normally closed, momentary operated pushbutton for the JOG pushbutton.

### RUN/JOG option #1

In the first wiring option (see Figure 17), connect the RUN/JOG switch and JOG pushbutton to the inhibit plug as shown below. The motor coasts to a stop when the RUN/JOG switch is set to JOG. Press the JOG pushbutton to jog the motor. Return the RUN/JOG switch to RUN for normal operation.

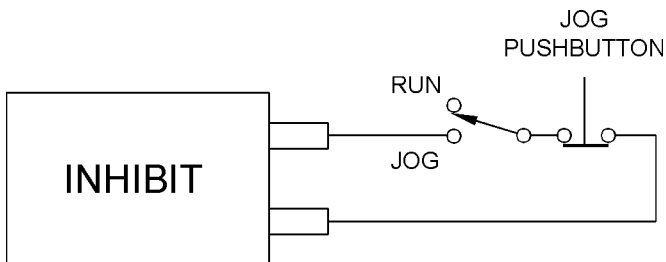
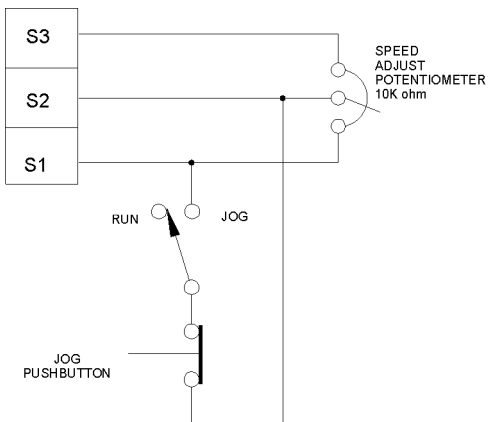

Figure 17. RUN/JOG Switch (first wiring option)

## RUN/JOG option #2

In the second wiring option, connect the RUN/JOG switch and the JOG pushbutton as shown in Figure 18. When the RUN/JOG switch is set to JOG, the motor decelerates to minimum speed (minimum speed is determined by the MIN SPD trimpot setting). Press the JOG pushbutton to jog the motor. Return the RUN/JOG switch to RUN for normal operation.



**Figure 18. RUN/JOG Switch (second wiring option)**

## Leader-follower application

In this application, use a PCM4 to monitor the speed of the leader motor (see Figure 19). The PCM4 isolates the leader motor from the follower drive, and outputs a voltage proportional to the leader motor's armature voltage. The follower drive uses this voltage reference to set the speed of the follower motor. An optional ratio potentiometer can be used to scale the PCM4 output voltage.

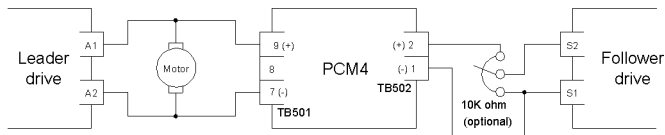
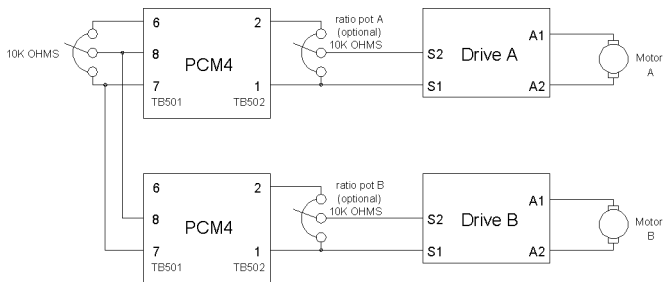

Figure 19. Leader-follower application

## Single speed potentiometer control of multiple drives

You can control multiple drives with a single speed potentiometer using a PCM4 at the input of each drive (see Figure 20). A PCM4 is used at the input of each drive for isolation. Optional ratio potentiometers can be used to scale the PCM4 output voltage, allowing independent control of each drive.



**Figure 20. Single Speed Potentiometer Control of Multiple Drives**

## Reversing

Always use a dynamic brake when reversing the motor direction (see Figure 21). Use a three pole, three position switch rated for the DC armature voltage and high braking current. Wait for the motor to stop completely before switching it to either the forward or reverse direction. See the *Dynamic Braking* section on page 29 for information on sizing the dynamic brake resistor.

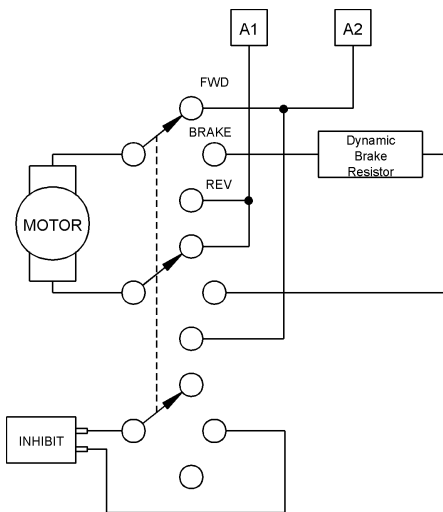
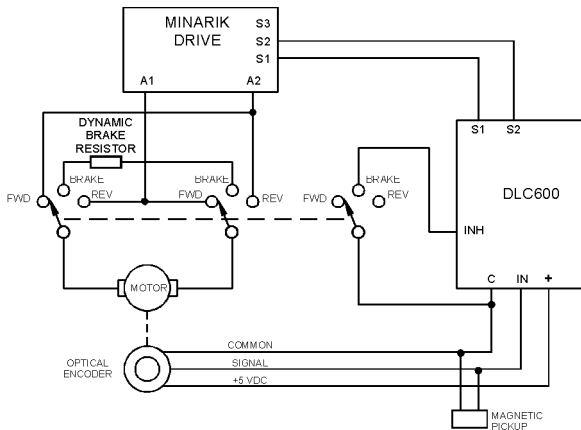

**Figure 21. Reversing Circuit Connection**

## Reversing with a DIGI-LOK® controller

A DIGI-LOK® controller, model DLC600, can be used in a reversing application. The DIGI-LOK® must be inhibited while braking. Without the inhibit feature, the DIGI-LOK® will continue to regulate. This will cause overshoot when the DIGI-LOK® is reengaged with the drive.

Figure 22 shows the reversing circuit connections with an XL Series drive and DIGI-LOK® controller. Note: Only one DLC option (Optical Encoder or Magnetic Pickup) may be used at a time.



**Figure 22. Reversing with a DLC600**

# Troubleshooting



## Warning

Dangerous voltages exist on the drive when it is powered. When possible, disconnect the drive while troubleshooting. High voltages can cause serious or fatal injury.

## Before troubleshooting

Perform the following steps before starting any procedure in this section:

- Disconnect AC line voltage from the drive.
- Check the drive closely for damaged components.
- Check that no conductive or other foreign material has become lodged on the printed circuit board.
- Verify that every connection is correct and in good condition.
- Verify that there are no short circuits or grounded connections.
- Check that the drive's rated armature outputs are consistent with the motor ratings.

For additional assistance, contact your local Minarik distributor, or the factory direct:

(800) MINARIK (phone) or (800) 394-6334 (fax).

## Diagnostic LEDs

XLA Series drives are equipped with the following diagnostic LEDs:

### POWER ON (IL501)

The red POWER LED lights whenever AC line voltage is applied to the drive.

### CURR LIM (IL502)

The green CURR LIM LED lights whenever the drive reaches current limit.

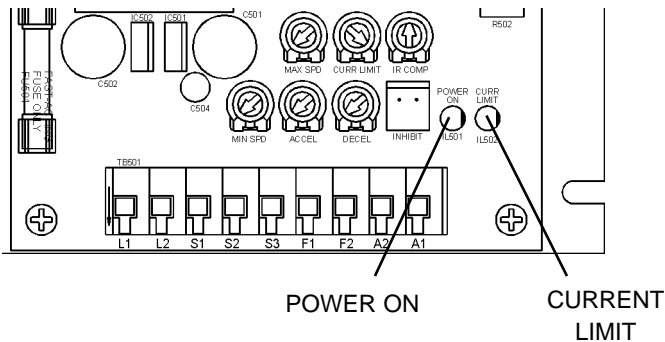

Figure 23. Diagnostic LED Location

<b>Symptom</b>	<b>Possible Causes</b>	<b>Suggested Solutions</b>
Line fuse blows	<ol style="list-style-type: none"><li data-bbox="384 240 622 300">1. Line fuses are not the correct size.</li><li data-bbox="384 521 622 619">2. Motor cable or armature shorted to ground.</li><li data-bbox="384 694 598 754">3. Field circuit is open.</li></ol>	<ol style="list-style-type: none"><li data-bbox="686 240 925 477">1. Check that line fuses are the correct size. See Replacement Parts section for the correct fuse size.</li><li data-bbox="686 521 883 652">2. Check motor cable and armature for shorts.</li><li data-bbox="686 694 904 793">3. Send drive to Minarik repair department.</li></ol>
Line fuse does not blow, but the motor does not run	<ol style="list-style-type: none"><li data-bbox="384 869 629 1001">1. Speed adjust potentiometer or input signal is set to zero speed.</li></ol>	<ol style="list-style-type: none"><li data-bbox="686 869 928 1001">1. Increase the speed adjust potentiometer or voltage setting.</li></ol>

<b>Symptom</b>	<b>Possible Causes</b>	<b>Suggested Solutions</b>
Line fuse does not blow, but motor does not run (cont.)	<ol style="list-style-type: none"><li>2. Speed adjust potentiometer or voltage input signal not connected to drive input properly; connections are open.</li><li>3. INHIBIT terminals are jumpered.</li><li>4. S2 is shorted to S0.</li><li>5. Drive is in current limit.</li><li>6. Drive is not receiving AC line voltage.</li></ol>	<ol style="list-style-type: none"><li>2. Check connections to input. Verify that connections are not open.</li><li>3. Remove jumper from INHIBIT terminals.</li><li>4. Remove short.</li><li>5. Check that the motor is not jammed. Increase the CURR. LIMIT setting if it is set too low.</li><li>6. Apply AC line voltage to L1 and L2.</li></ol>

<b>Symptom</b>	<b>Possible Causes</b>	<b>Suggested Solutions</b>
Line fuse does not blow, but motor does not run (cont.)	7. Motor is not connected.	7. Connect motor to A1 and A2.
Motor runs too fast at maximum speed setting	1. MIN SPD and MAX SPD settings are too high.  2. Motor field connections are loose (shunt wound motors only).	1. Recalibrate MIN SPD and MAX SPD.  2. Check motor field connections.

<b>Symptom</b>	<b>Possible Causes</b>	<b>Suggested Solutions</b>
Motor runs too slow or too fast	<ol style="list-style-type: none"> <li>1. Voltage switches set incorrectly. (NOTE: This does not apply to XL1100A drives.)</li> <li>2. MIN SPD and MAX SPD not calibrated.</li> <li>3. Motor field not properly connected (shunt wound motors only).</li> </ol>	<ol style="list-style-type: none"> <li>1. Verify all switch settings.</li> <li>2. Calibrate MIN SPD and MAX SPD.</li> <li>3. Verify motor field connections.</li> </ol>
Motor will not reach the desired speed	<ol style="list-style-type: none"> <li>1. MAX SPD setting is too low.</li> <li>2. IR COMP setting is too low.</li> <li>3. Motor is overloaded.</li> </ol>	<ol style="list-style-type: none"> <li>1. Increase MAX SPD setting.</li> <li>2. Increase the IR COMP setting.</li> <li>3. Check motor load. Resize the motor or drive if necessary.</li> </ol>

<b>Symptom</b>	<b>Possible Causes</b>	<b>Suggested Solutions</b>
Motor pulsates or surges under load	<ol style="list-style-type: none"><li data-bbox="384 240 622 303">1. IR COMP is set too high.</li><li data-bbox="384 451 622 547">2. Motor “bouncing” in and out of current limit.</li></ol>	<ol style="list-style-type: none"><li data-bbox="674 240 905 405">1. Adjust the IR COMP setting slightly CCW until the motor speed stabilizes.</li><li data-bbox="674 451 943 582">2. Make sure motor is not undersized for load; calibrate CURR.LIMIT trimpot.</li></ol>

## Replacement Parts

Replacement parts are available form Minarik Corporation and its distributors for this drive series.

**Table 5. Replacement Parts**

Model No.	Symbol	Description	Minarik P/N
XL1100A	BR601	KBPC3506 Bridge	073-0008
	C503	1500 mF, 250 VDC Capacitor	011-0089
	D501	16 A, 600 V Diode	071-0055
	Q501, Q502	IRF640 POWER MOSFET	070-0043
	R501, R502	0.01 ohm, 5 W Resistor	032-0129
	T501	ST-436 Transformer	230-0071
	TH501	WS1090 20A Limiter	033-0007
	FU501	15A, 3 AB Normal-Blo Fuse	050-0018
	pot kit	10K ohm, 5 W Potentiometer	202-0003
	XL3025A	BR501	GBU8J Bridge
C503		470 mF, 400 VDC Capacitor	011-0120
D501		8 A, 600 V Diode	071-0055
Q501		8 A, 500 V MOSFET	070-0075
R501, R502		0.05 ohm, 5 W Resistor	032-0113
T501		3FD-436 Transformer	230-0072
TH501		10 ohm NTC Thermistor	033-0005
FU501		8 A, 3 AB Normal-Blo Fuse	050-0023
pot kit		10K ohm, 5 W Potentiometer	202-0003
XL3050A		BR601	KBPC3506 Bridge
	C503	680mF, 400 VDC Capacitor	011-0080
	D501	16 A, 600 V Diode	071-0044
	Q501, Q502	8 A, 500 V MOSFET	070-0075
	R501, R502	0.05 ohm, 5 W Resistor	032-0113
	T501	3FD-436 Transformer	230-0072
	TH501	WS380 15 A Imax Limiter	033-0006
	FU501	10 A, 3 AB Normal-Blo Fuse	050-0024
	pot kit	10K ohm, 5 W Potentiometer	202-0003

XL3200A	BR601	KBPC3506 Bridge	073-0008
	C503	1000 mF, 400 VDC Capacitor	011-0099
	D501	MUR1560 Diode	071-0044
	Q501, Q502	20 A, 500 V MOSFET	070-0066
	R501, R502	0.01 ohm, 5 W Resistor	032-0129
	T501	3FD-436 Transformer	230-0072
	TH501	WS1090 20 A Limiter	033-0007
	FU501	15 A, 3 AB Normal-Blo Fuse	050-0018
	pot kit	10K ohm, 5 W Potentiometer	202-0003

**POTENTIOMETER KIT CONTENTS (KIT P/N 202-0003)**

1 ea 10K OHM, 5W, 5% TOL. Potentiometer	120-0009
1 ea 3/8-32 X 1/2 NUT	151-0007
1 ea 3/8IN INT TOOTH LOCK WSHR	152-0007
1 ea POT INSULATING WASHER	156-0022

**FUSE KIT CONTENTS****1 - 8A FUSE KIT (050-0068)**

2 EA 1 AMP 3AG FAST-ACTING FUSE	050-0042
2 EA 1.5 AMP 3AG FAST-ACTING	050-0026
2 EA 3 AMP 3AG FAST-ACTING FUSE	050-0021
2 EA 5 AMP 3AG FAST-ACTING FUSE	050-0022
2 EA 8 AMP 3AG FAST-ACTING FUSE	050-0059
1 EA 0.5 AMP PICO FUSE	050-0074

**3 - 10A FUSE KIT (050-0070)**

2 EA 3 AMP 3AG FAST-ACTING FUSE	050-0021
2 EA 5 AMP 3AG FAST-ACTING FUSE	050-0022
2 EA 8 AMP 3AG FAST-ACTING FUSE	050-0059
2 EA 10 AMP 3AB NORMAL-BLO FUSE	050-0024
1 EA 0.5 AMP PICO FUSE	050-0074

**5 - 15A FUSE KIT (050-0072)**

2 EA 5 AMP 3AG FAST-ACTING FUSE	050-0022
2 EA 8 AMP 3AG FAST-ACTING FUSE	050-0059
2 EA 10 AMP 3AB NORMAL-BLO FUSE	050-0024
2 EA 15 AMP 3AB NORMAL-BLO FUSE	050-0018
1 EA 0.5 AMP PICO FUSE	050-0074

---

# Certificate of Compliance

Minarik Corporation hereby certifies that its XLA series drives (models XL3025A, XL3050A, and XL3200A) have been approved to bear the “CE” mark provided the conditions of approval have been met by the end user. The XL series has been tested to the following test specifications:

EN55014:1993 (emissions), and

EN50082-1:1992 (immunity)

Compliance allows Minarik’s XL series to bear the CE mark.

The end user, as described herein, falls into one of two categories:

1. The Consumer will deploy a stand-alone unit as an integral, yet external, portion of the machine being operated.
2. The Original Equipment Manufacturer (OEM) will implement the product as a component of the machine being manufactured.

## AC line filters

In addition to EMI/RFI safeguards inherent in the XLA series' design, external filtering is required. Minarik requires the AC line filters listed in Table 6. Use model CE04XL with drives rated for 3 ADC or below, model CE10XL with drives rated for 10 ADC or below, and model CE15XL for drives rated for 15 ADC or below. If the end-user is using a CE-approved motor, the correct filter from Table 6 is all that is necessary to meet the EMC directives listed herein.

**Table 6. Minarik AC Line Filters**

<b>Minarik Model Number</b>	<b>CE04XL</b>	<b>CE10XL</b>	<b>CE15XL</b>
Rated Current	4 A	10 A	15A
Inductance	17.46 mH	14.26 mH	10.0 mH
Capacitance			
Line to Line	0.811 mF	0.811 mF	0.082 mF
Line to Ground	0.0056 mF	0.0056 mF	0.0056 mF
Discharge Resistor	330 K ohms	330 K ohms	330 K ohms

Wire the AC line filter within 10 inches (25 cm) of the drive as shown in Figure 24 (page 62). The ground connection from the filter must be wired to solid earth ground (resistance less than 500 ohms), not machine ground. This is very important! If the end-user is using a CE-approved motor, the correct filter from Table 6 is all that is necessary to meet the CE directives listed herein.

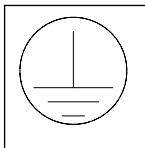

---

## End User Responsibility

The end user must use the filtration listed in this addendum to comply with CE. The OEM may choose to provide alternative filtering that encompasses the Minarik drive and other electronics within the same panel. The OEM has this liberty because CE is a machinery directive.

Whether or not every component in the OEM's machinery meets CE, the OEM must still submit his machine for CE approval. Thus, no component must necessarily meet CE within the machine, as long as the OEM takes the necessary steps to guarantee the machine does meet CE. By the same token, even if every component in the OEM's machine does meet CE, the machine will not necessarily meet CE as a machine.

Using CE-approved wiring practices, such as proper shielding, and the filters should assure the drive will meet EN50081 (1993 emissions standard) and EN50082-2 (1995 immunity standard).

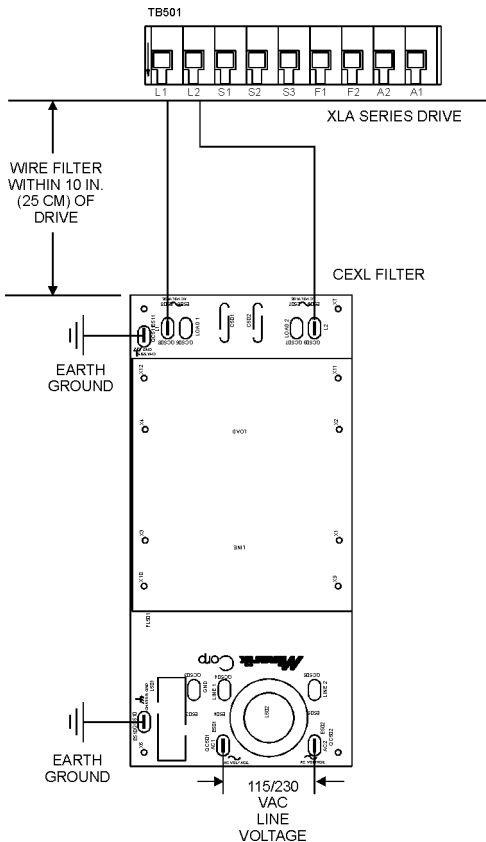

Figure 24. CEXL Filter Connection to XLA Series Drive

# Unconditional Warranty

## A. Warranty

Minarik Corporation (referred to as "the Corporation") warrants that its products will be free from defects in workmanship and material for twelve (12) months or 3,000 hours, whichever comes first, from date of manufacture thereof. Within this warranty period, the Corporation will repair or replace, at its sole discretion, such products that are returned to Minarik Corporation, 901 East Thompson Avenue, Glendale, CA 91201-2011 USA.

This warranty applies only to standard catalog products, and does not apply to specials. Any returns for special controls will be evaluated on a case-by-case basis. The Corporation is not responsible for removal, installation, or any other incidental expenses incurred in shipping the product to and from the repair point.

## B. Disclaimer

The provisions of Paragraph A are the Corporation's sole obligation and exclude all other warranties of merchantability for use, express or implied. The Corporation further disclaims any responsibility whatsoever to the customer or to any other person for injury to the person or damage or loss of property of value caused by any product that has been subject to misuse, negligence, or accident, or misapplied or modified by unauthorized persons or improperly installed.

## C. Limitations of Liability

In the event of any claim for breach of any of the Corporation's obligations, whether express or implied, and particularly of any other claim or breach of warranty contained in Paragraph A, or of any other warranties, express or implied, or claim of liability that might, despite Paragraph B, be decided against the Corporation by lawful authority, the Corporation shall under no circumstances be liable for any consequential damages, losses, or expense arising in connection with the use of, or inability to use, the Corporation's product for any purpose whatsoever.

An adjustment made under warranty does not void the warranty, nor does it imply an extension of the original 12-month warranty period. Products serviced and/or parts replaced on a no-charge basis during the warranty period carry the unexpired portion of the original warranty only.

If for any reason any of the foregoing provisions shall be ineffective, the Corporation's liability for damages arising out of its manufacture or sale of equipment, or use thereof, whether such liability is based on warranty, contract, negligence, strict liability in tort, or otherwise, shall not in any event exceed the full purchase price of such equipment.

Any action against the Corporation based upon any liability or obligation arising hereunder or under any law applicable to the sale of equipment or the use thereof, must be commenced within one year after the cause of such action arises.

## Other drives from Minarik Corporation:



NRGD Series



DLC600

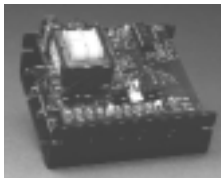

MMRGD Series



BOSS Series

**Minarik** Automation  
& Control

901 East Thompson Avenue  
Glendale, California 91201-2011

Tel: (800) MINARIK

Fax: (800) 394-6334

[www.minarikcorp.com](http://www.minarikcorp.com)

Document Number 250-0233, Revision 5

Printed in the U.S.A – 5/01

\$12.00 North America, \$13.00 Outside North America