

Model 200-0386A

Switching Logic Board

User's Manual

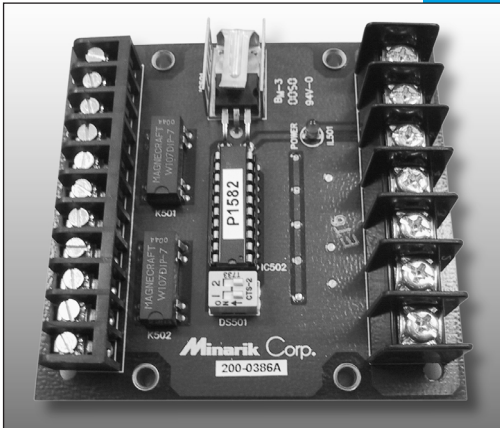

For Use With Minarik
Full-Wave Regenerative Drives

Copyright © 2002 by
Minarik Corporation

All rights reserved. No part of this manual may be reproduced or transmitted in any form without written permission from Minarik Corporation. The information and technical data in this manual are subject to change without notice. Minarik Corporation and its Divisions make no warranty of any kind with respect to this material, including, but not limited to, the implied warranties of its merchantability and fitness for a given purpose. Minarik Corporation and its Divisions assume no responsibility for any errors that may appear in this manual and make no commitment to update or keep current the information in this manual. MVD062802

Printed in the United States of America.

Safety Warnings



- Have a qualified electrical maintenance technician install, adjust, and service this equipment. Follow the National Electrical Code and all other applicable electrical and safety codes, including the provisions of the Occupational Safety and Health Act (OSHA) when installing equipment.
- Reduce the chance of an electrical fire, shock, or explosion by proper grounding, over current protection, thermal protection, and enclosure. Follow sound maintenance procedures.
- It is possible for a drive to run at full speed as a result of a component failure. Install a master switch in the AC line for stopping the drive in an emergency.
- When the switching logic board is connected to a variable speed regenerative drive it is isolated from earth ground. Circuit potentials are at 115 VAC or 230 VAC above earth ground. Avoid direct contact with the printed circuit board or with circuit elements to prevent the risk of serious injury or fatality. Use a non-metallic screwdriver for any necessary adjustments.

Contents

Safety Warnings	i
Specifications	1
Dimensions	2
General Information	3
Installation	4
Mounting the Logic Board	4
Wiring	5
Screw terminal block	5
Speed adjust potentiometer	6
Shielding Guidelines	9
Modes of Operation	10
Pushbutton switches	11
Limit switches	11
Foot pedals	11
DIP switches	11
Pushbutton operation: FORWARD/STOP/REVERSE	12
Pushbutton operation: RUN/STOP	13
Pushbutton operation: jog FORWARD/jog REVERSE	14
Pushbutton operation: jog RUN	15
Limit switch operation: no automatic reversing	16
Limit switch operation: FORWARD/STOP/REVERSE, 1 Cycle	17
Limit switch operation: automatic cycling	18
Foot pedal operation: FORWARD/STOP/REVERSE	20
Foot pedal operation: RUN/STOP	21

Connection to Minarik Regenerative Drives**22****Unconditional Warranty****inside back cover**

Illustrations

Figure 1. Model 200-0386A Switching Logic Board Layout and Dimensions	2
Figure 2. Screw Terminal Block	5
Figure 3. Speed Adjust Potentiometer	6
Figure 4. Single Speed Potentiometer Connections	7
Figure 5. Two Speed Potentiometer Connection	8
Figure 6. Pushbutton Operation: FWD/STOP/REV	12
Figure 7. Pushbutton Operation: RUN/STOP	13
Figure 8. Pushbutton Operation: jog Forward/jog Reverse	14
Figure 9. Pushbutton Operation: jog RUN	15
Figure 10. Limit switch operation: no automatic reversing	16
Figure 11. Limit Switch Operation: FWD/STOP/REV, 1 cycle	17
Figure 12. Limit Switch Operation: automatic cycling	19
Figure 13. Foot pedal operation: FORWARD/STOP/REVERSE	20
Figure 14. Foot pedal operation: RUN/STOP	21
Figure 15. Connection diagram: Switching Logic Board (200-0386A) to RG100UC/RG200UC	22
Figure 16. Connection diagram: Switching Logic Board (200-0386A) to RG300UA/RG310UA/RG400UA	23
Figure 17. Connection diagram: Switching Logic Board (200-0386A) to RG500UA/RG510UA	24

Illustrations (cont.)

Figure 18. Connection diagram: Switching Logic Board (200-0386A) to RG5500U	25
Figure 19. Connection diagram: Switching Logic Board (200-0386A) to MRG30U/MMRG31U/MMRG40U	26
Figure 20. Connection diagram: Switching Logic Board (200-0386A) to MMRGD03/MMRGD10	27
Figure 21. Connection diagram: Switching Logic Board (200-0386A) to RG60U	28
Figure 22. TTL Logic Input	29
Figure 23. NPN Open Collector Input	30
Figure 24. Contact Input	31

Specifications

Input Power	+15 VDC @ 20 mA -15 VDC @ 1.5 mA
Acceptable Input Devices	Dry Contacts Current-Sinking Open Collectors TTL Logic Devices
Number of Switching Modes	Four (4)
Speed adjust potentiometer	10 K Ohms
Maximum Reference Voltage to Drive	±15 VDC
Ambient Operating Temperature Range	10°C - 40°C
Weight	0.2 lbs

Note: This switching logic board is specifically designed to operate with Minarik control models RG100UC, RG200UC, RG300U, RG400U, RG500U, RG5500U, and RG60U. Consult factory before attempting to use with other models.

Dimensions

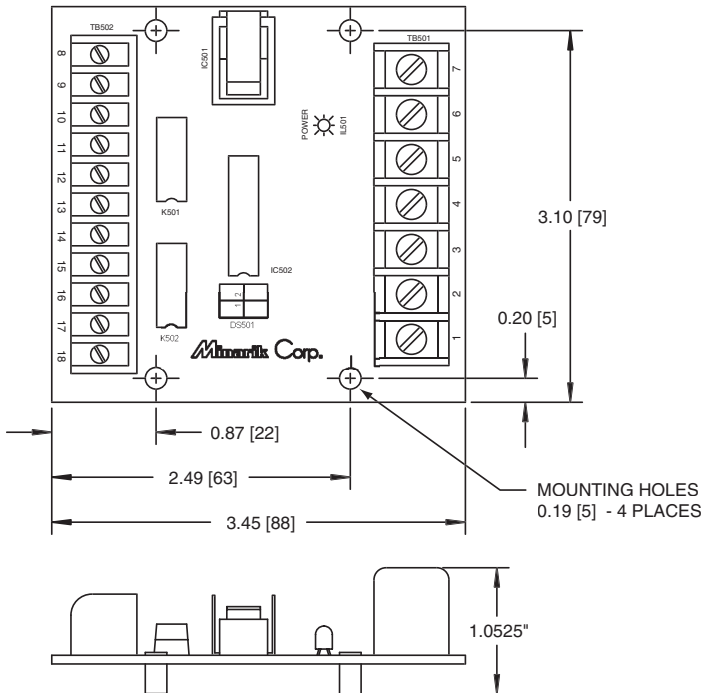

Figure 1. Model 200-0386A Switching Logic Board Layout and Dimensions

General Information



Caution

Regenerative braking imposes very high stress on the rotating components of the drive train. It is very important that these deceleration forces be considered before selecting a drive system that applies regenerative braking to a gearmotor or other gearbox.

Minarik Corporation's model 200-0386A provides the logic interface between the regenerative drive and pushbutton stations, foot switches, or programmable controls. It accepts dry contact mechanical closures, current-sinking open collectors, and TTL logic devices.

The limit switch logic board has four operating modes, which can be configured nine different ways. Select the one that fits your application and follow the wiring and DIP switch instructions for that configuration.

The speed adjust potentiometer (10K ohms, 2 watts) is wired through the logic board (200-0386A) module, rather than directly to the regenerative drive. Use either one potentiometer for both forward and reverse speeds (Figure 4, page 7) or if different speeds are required in each direction – one potentiometer for forward and one potentiometer for reverse speed settings (Figure 5, page 8).

Installation

Mounting the Logic Board

Logic board components are sensitive to electrostatic fields. Avoid contact with the circuit board directly.

Protect the logic board from dirt, moisture, and accidental contact. Provide sufficient room for access to the terminal block.

Mount the logic board away from other heat sources. Operate within the specified ambient operating temperature range. The operating temperature range for the 200-0386A is 10°C through 40° C.

Prevent loose connections by avoiding excessive vibration of the logic board.

Mount the logic board in either a horizontal or vertical plane using the four 0.19 inch [5 mm] mounting holes located on the board.

Wiring

Screw terminal block

Connections to Minarik's 200-0386A logic board are made to a screw terminal block. There are two screw terminal blocks on the board. The large one is shown in Figure 2. The smaller screw terminal block has a similar connection style to the one shown.

Using a screwdriver, turn the terminal block screw counter-clockwise to open the wire clamp. Insert stripped wire into the wire clamp. Turn the terminal block screw clockwise to clamp the wire.

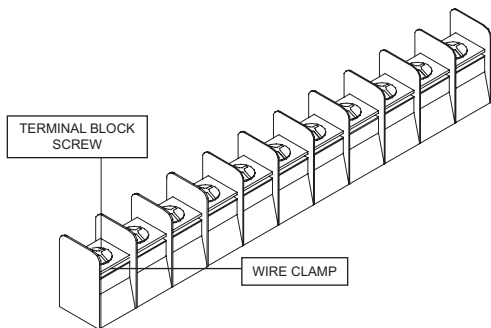

Figure 2. Screw Terminal Block

Speed adjust potentiometer



Warning

Be sure that the potentiometer tabs do not make contact with the potentiometer enclosure. Grounding the input will cause damage to the regenerative drive.

Install the circular insulating disk between the panel and the 10K ohm speed adjust pot. Mount the speed adjust pot through a 0.38 inch (10mm) hole with the hardware provided (Figure 3). Twist the speed adjust pot wire to avoid picking up unwanted electrical noise. If potentiometer leads are longer than 18 inch (457mm), use shielded cable. Logic lines of this length act as an antenna and can pick up noise from the drive components, noise from other devices or other ground wires, or voltage from power lines that can cause erratic operation. **The 200-0386A does not include this pot.**

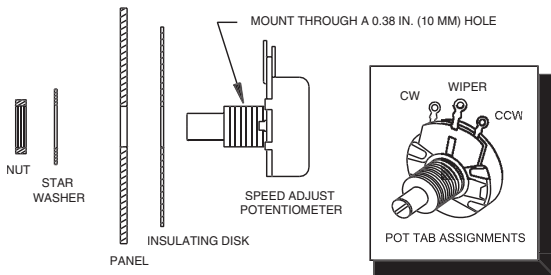

Figure 3. Speed Adjust Potentiometer

It may be necessary to earth ground the shielded cable. If noise is produced by devices other than the drive, ground the shield at the drive end. If noise is generated by a device on the drive, ground the shield at the end away from the drive. Do not ground both ends of the shield.

The following diagrams show the potentiometer connections to terminal block 2 (TB2).

Use Figure 4 when a single speed is desired in both the forward and reverse directions.

Use Figure 5 when one speed is desired in the forward direction, and a different speed is desired in the reverse direction.

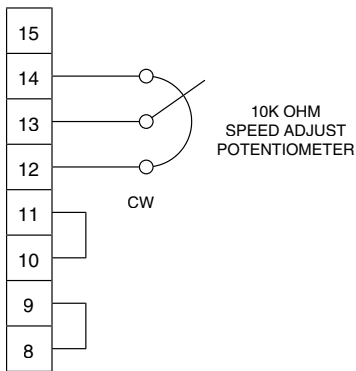

Figure 4. Single Speed Potentiometer Connections

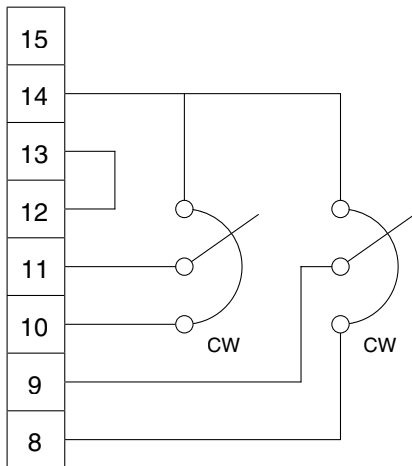

Figure 5. Two Speed Potentiometer Connection

Shielding Guidelines



Warning

Under no circumstances should power and logic leads be bundled together. Induced voltage can cause unpredictable behavior in any electronic device, including motor controls.

As a general rule, Minarik recommends shielding of all conductors.

If it is not practical to shield power conductors, Minarik recommends shielding all logic-level leads. If shielding logic leads is not practical, the user should twist all logic leads with themselves to minimize induced noise.

It may be necessary to earth ground the shielded cable. If noise is produced by devices other than the drive, ground the shield at the drive end. If noise is generated by a device on the drive, ground the shield at the end away from the drive. Do not ground both ends of the shield.

If the drive continues to pick up noise after grounding the shield, it may be necessary to add AC line filtering devices, or to mount the drive in a less noisy environment.

Modes of Operation

The limit switch logic board has four (4) different modes of operation which can be configured into nine (9) difference connections. They are as follows:

1) FORWARD/STOP/REVERSE

- Pushbutton Operation
- Limit Switch Operation
- Foot Pedal Operation

2) RUN/STOP

- Pushbutton Operation
- Foot Pedal Operation
- Limit Switch Operation (no automatic reversing)

3) jog FORWARD/jog REVERSE

- Pushbutton Operation

4) jog RUN

- Pushbutton Operation
- Limit Switch Operation

Pushbutton switches

Pushbutton switches are momentary operated type. RUN, FWD, and REV switches are normally open. STOP switches are normally closed.

Limit switches

Limit switches are single pole, single throw, normally closed.

Foot pedals

Foot pedals are single pole, single throw, normally open.

DIP switches

Use a small screwdriver to change DIP switch settings. The arrow on the dip switch box indicates the ON position.

Pushbutton operation: FORWARD/STOP/REVERSE

In this mode the appropriate pushbutton initiates travel. The motor is reversed by pressing the opposite direction pushbutton. The stop pushbutton will regeneratively brake the motor.

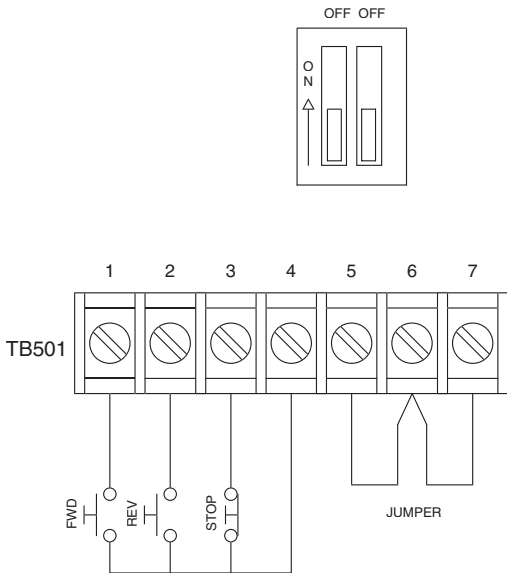

Figure 6. Pushbutton Operation: FWD/STOP/REV

Pushbutton operation: RUN/STOP

In this mode the RUN pushbutton is actuated to start the motor. The motor will continue to run until the STOP pushbutton is depressed. This mode does not allow reversing. If the motor runs in the wrong direction, shut down the system and reverse the armature connections to the regenerative drive.

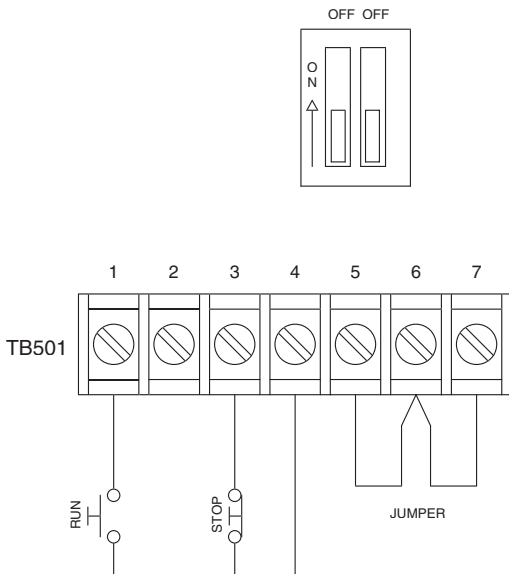

Figure 7. Pushbutton Operation: RUN/STOP

Pushbutton operation: jog FORWARD/jog REVERSE

In this mode the motor turns only when the forward or reverse pushbutton is being depressed. To reverse the motor, first release the activated pushbutton to regeneratively brake the motor. Then push the opposite direction pushbutton.

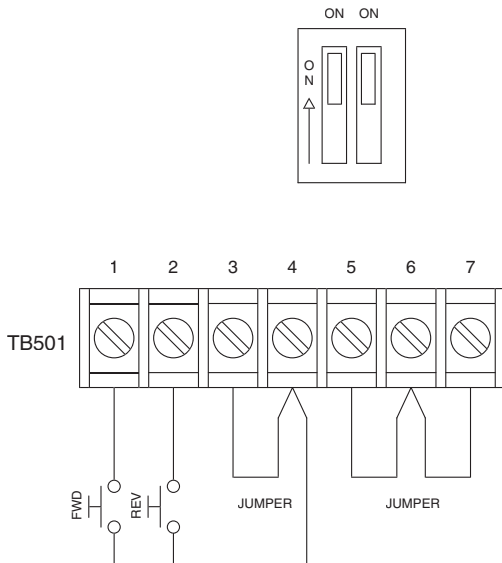

Figure 8. Pushbutton Operation: jog Forward/jog Reverse

Pushbutton operation: jog RUN

In this mode the motor turns only as long as the RUN pushbutton is depressed. When the pushbutton is released the drive will regeneratively brake the motor. If the motor runs in the wrong direction, shut down the system and reverse the armature connections to the regenerative drive.

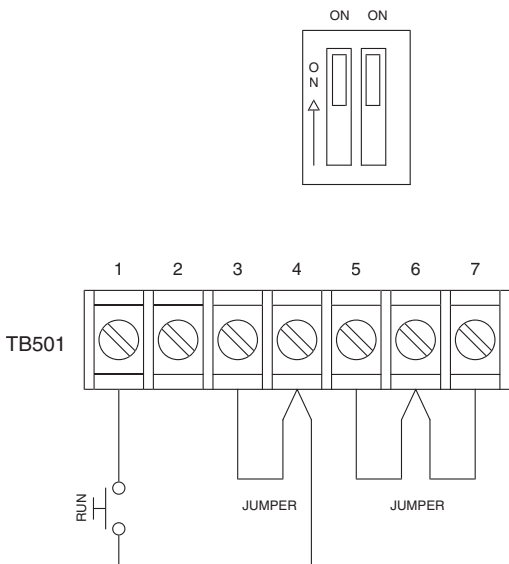

Figure 9. Pushbutton Operation: jog RUN

Limit switch operation: no automatic reversing

In this mode activating the appropriate pushbutton will initiate travel. The motor will regeneratively brake when the corresponding limit switch is actuated (opened) or when the STOP pushbutton is depressed. If travel is interrupted by STOP before the limit switch is reached, it can be resumed by pressing the appropriate direction pushbutton.

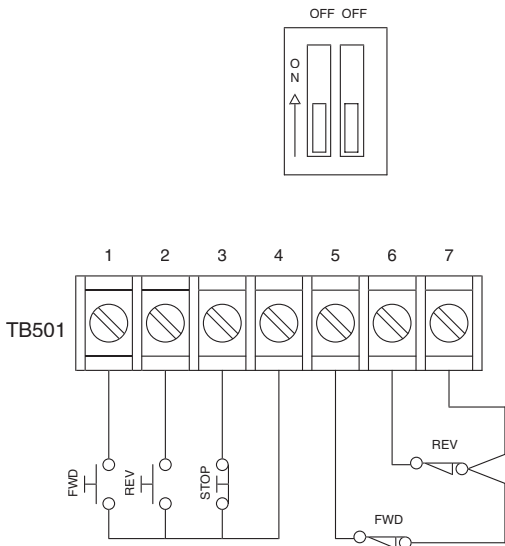

Figure 10. Limit switch operation: no automatic reversing

Limit switch operation: FORWARD/STOP/REVERSE, 1 Cycle

In this single-cycle mode the motor automatically returns to the REV limit switch location. It normally begins at that site with the actuation of the FWD pushbutton. If the starting position is not at the FWD limit switch, press FWD to complete the balance of the automatic FWD/STOP/REV cycle or press REV to complete the REV portion of the cycle.

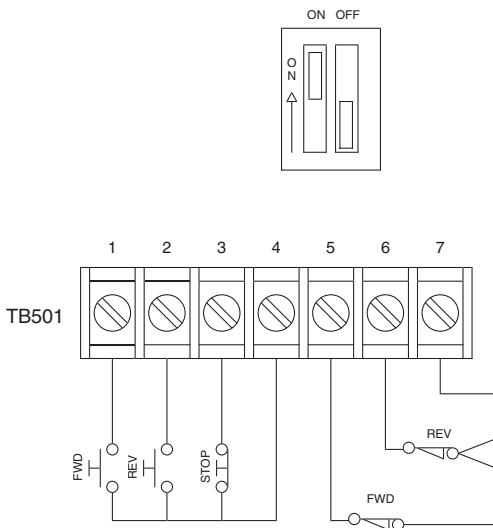

Figure 11. Limit Switch Operation: FWD/STOP/REV, 1 cycle

Limit switch operation: automatic cycling

In this mode the motor will continuously cycle the load between the FWD and REV limit switches. To stop the cycling process, press the STOP pushbutton. Re-starting the cycle is dependent upon the position of the machine when stopped:

- If stopping occurs with the FWD limit switch activated, the REV pushbutton must be pressed to re-start.
- If stopping occurs with the REV limit switch activated, the FWD pushbutton must be pressed to re-start the cycle.
- If stopping occurs between the FWD and REV limit switches, either pushbutton may be pressed to re-start the cycle.

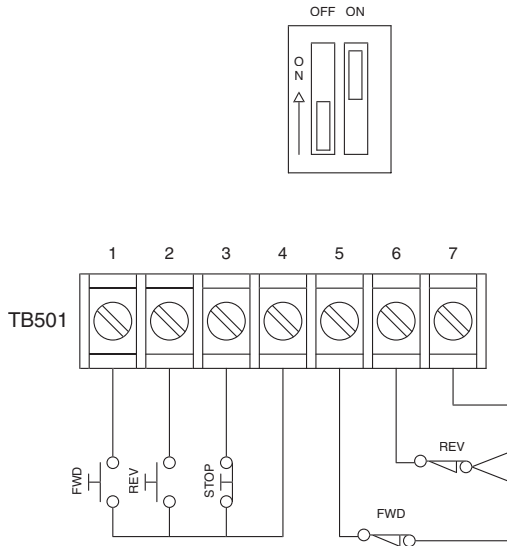

Figure 12. Limit Switch Operation: automatic cycling

Foot pedal operation: FORWARD/STOP/REVERSE

In this mode the motor runs as long as a pedal is depressed. When the pedal is released the drive will regeneratively brake the motor. When reversing the direction of travel it is necessary to release one pedal before depressing the other.

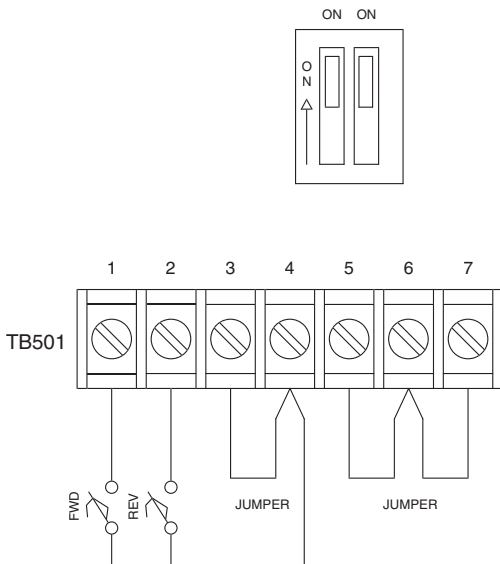

Figure 13. Foot pedal operation:
FORWARD/STOP/REVERSE

Foot pedal operation: RUN/STOP

In this mode the motor runs as long as the pedal is depressed. Release the pedal and the drive will regeneratively brake the motor. If the motor runs in the wrong direction, shut down the system and reverse the armature connections to the regenerative drive.

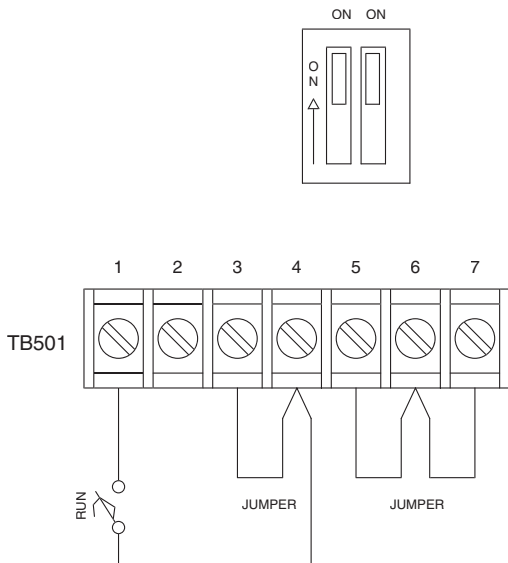
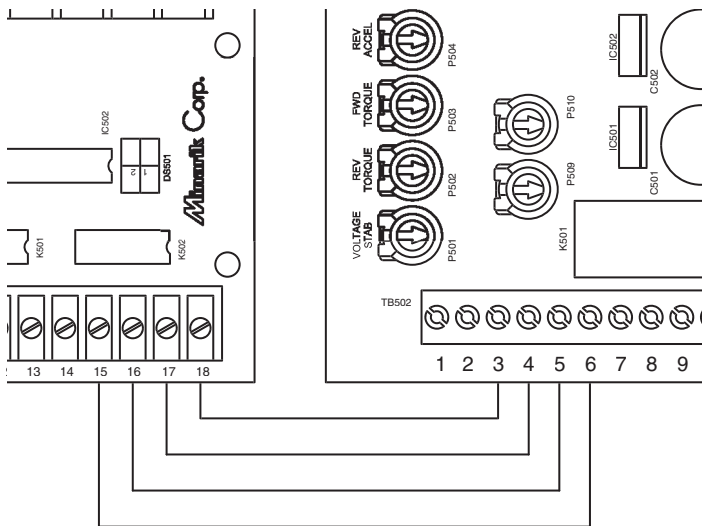

Figure 14 Foot pedal operation: RUN/STOP

Connection to Minarik Regenerative Drives



200-0386A

RG100UC/REG200UC

Figure 15. Connection diagram: Switching Logic Board (200-0386A) to RG100UC/REG200UC

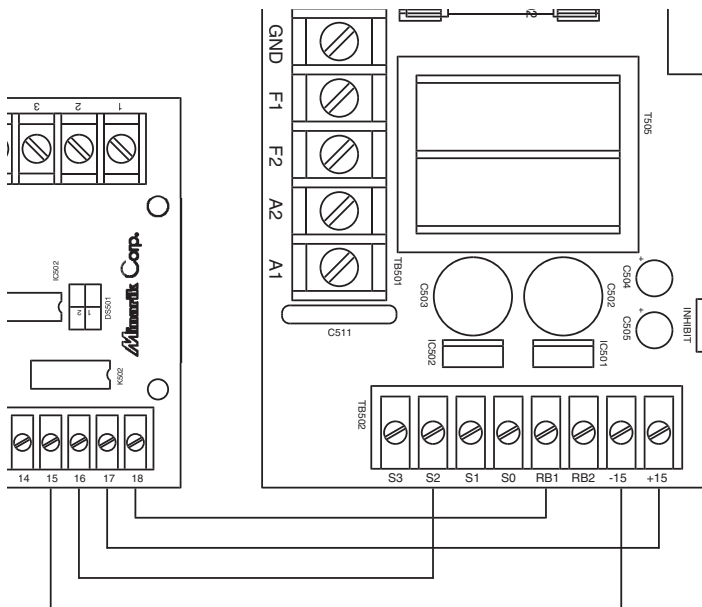

200-0386A

RG300UA/RG310UA/
RG400UA

Figure 16. Connection diagram: Switching Logic Board (200-0386A) to RG300UA/RG310UA/RG400UA

200-0386A

RG500UA/RG510UA

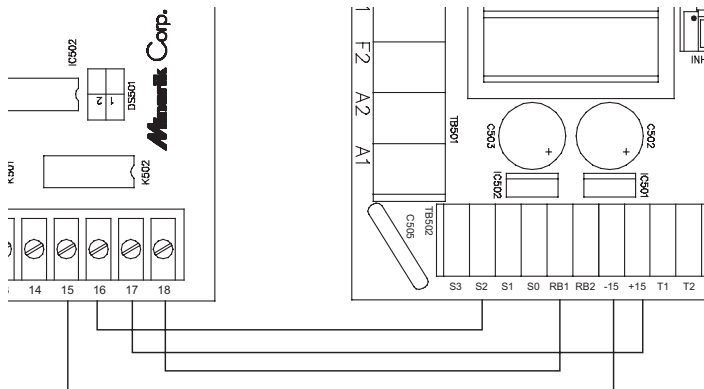

Figure 17. Connection diagram: Switching Logic Board (200-0386A) to RG500UA/RG510UA

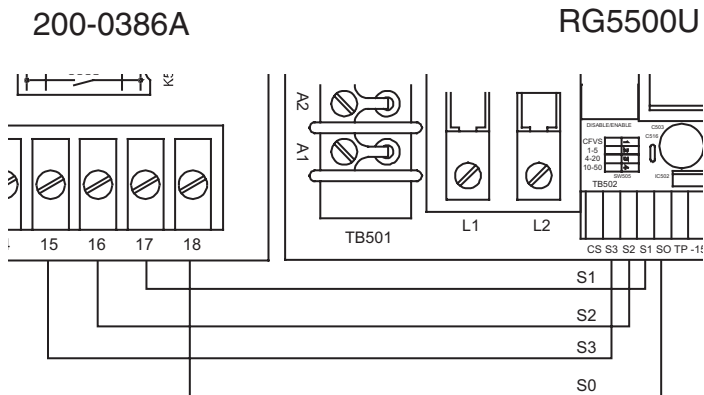

Figure 18. Connection diagram: Switching Logic Board (200-0386A) to RG5500U

MMRG30U/MMRG31U/
MMRG40U

200-0386A

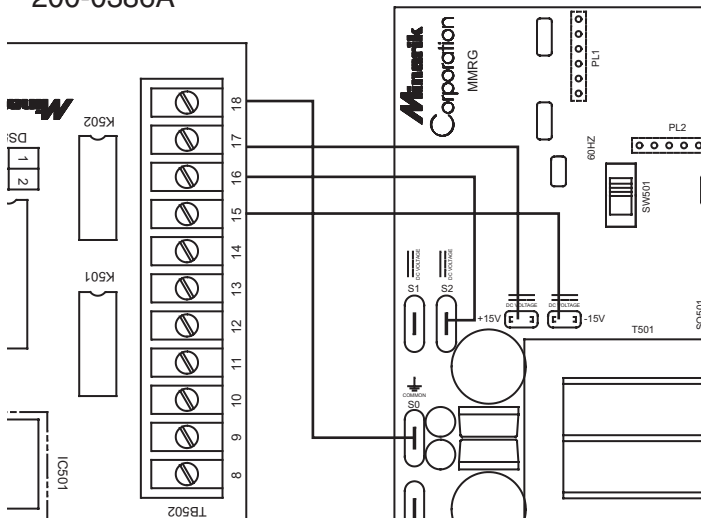

Figure 19. Connection diagram: Switching Logic Board (200-0386A) to MMRG30U/MMRG31U/MMRG40U

200-0386A

MMRGD03/MMRGD10

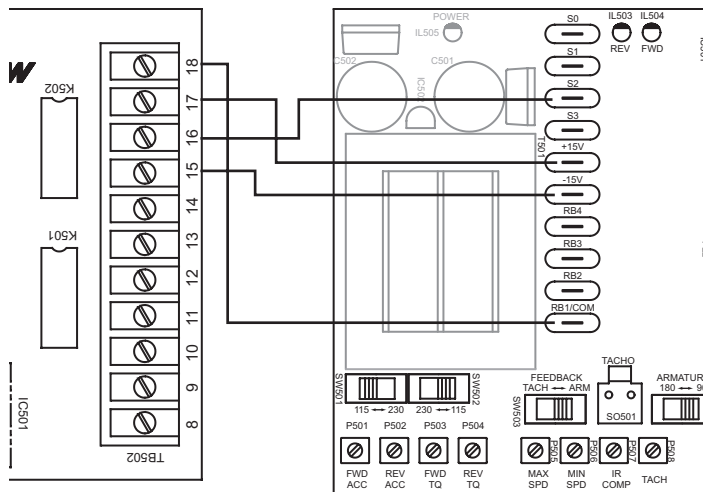
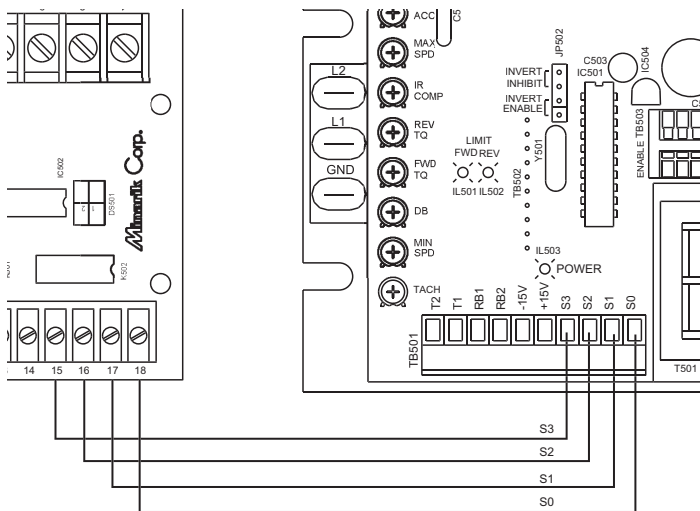

Figure 20. Connection diagram: Switching Logic Board (200-0386A) to MMRGD03/MMRGD10



200-0386A

RG60U

Figure 21. Connection diagram: Switching Logic Board (200-0386A) to RG60U

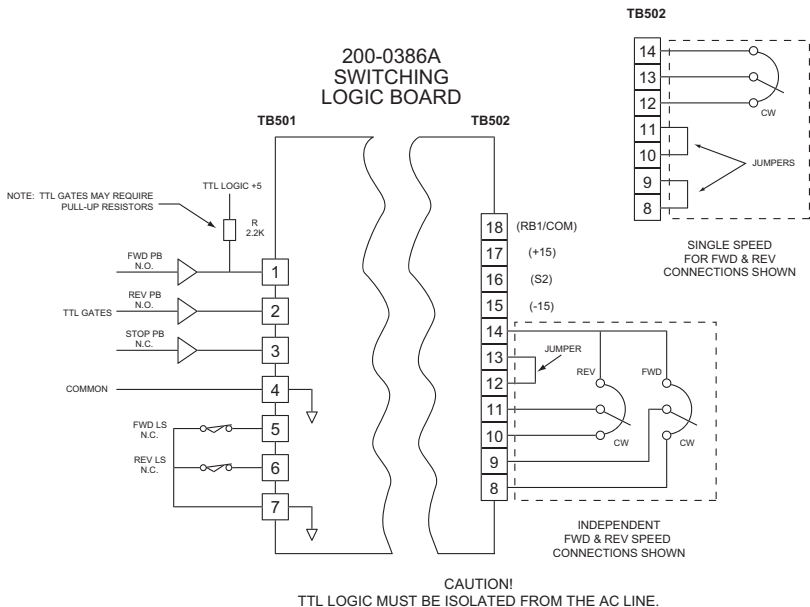

Figure 22. TTL Logic Input

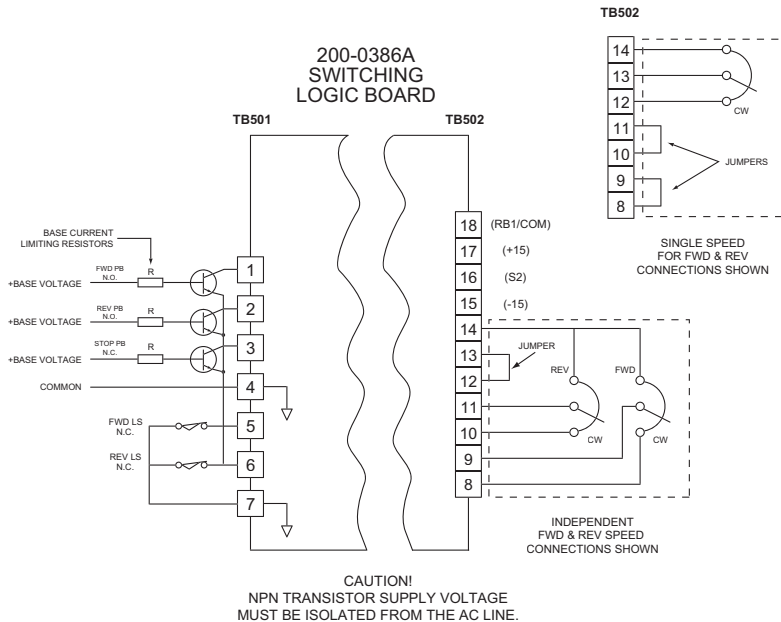

Figure 23. NPN Open Collector Input

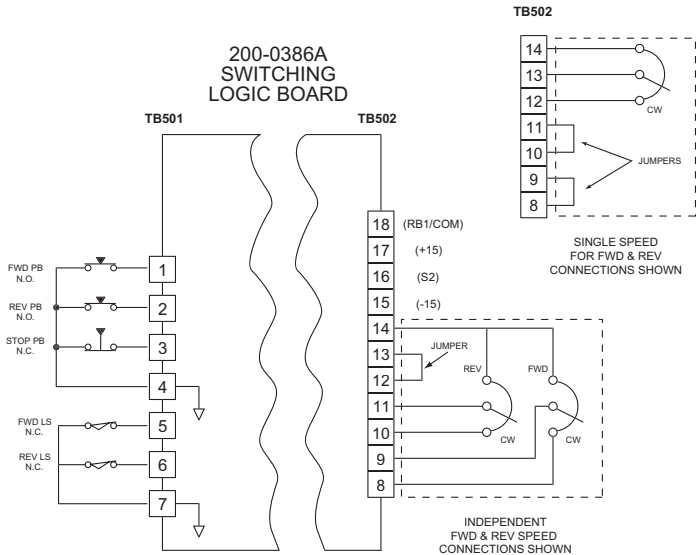

Figure 24. Contact Input

NOTES

Unconditional Warranty

A. Warranty

Minarik Corporation (referred to as "the Corporation") warrants that its products will be free from defects in workmanship and material for twelve (12) months or 3,000 hours, whichever comes first, from date of manufacture thereof. Within this warranty period, the Corporation will repair or replace, at its sole discretion, such products that are returned to Minarik Corporation, 901 East Thompson Avenue, Glendale, CA 91201-2011 USA.

This warranty applies only to standard catalog products, and does not apply to specials. Any returns for special controls will be evaluated on a case-by-case basis. The Corporation is not responsible for removal, installation, or any other incidental expenses incurred in shipping the product to and from the repair point.

B. Disclaimer

The provisions of Paragraph A are the Corporation's sole obligation and exclude all other warranties of merchantability for use, express or implied. The Corporation further disclaims any responsibility whatsoever to the customer or to any other person for injury to the person or damage or loss of property of value caused by any product that has been subject to misuse, negligence, or accident, or misapplied or modified by unauthorized persons or improperly installed.

C. Limitations of Liability

In the event of any claim for breach of any of the Corporation's obligations, whether express or implied, and particularly of any other claim or breach of warranty contained in Paragraph A, or of any other warranties, express or implied, or claim of liability that might, despite Paragraph B, be decided against the Corporation by lawful authority, the Corporation shall under no circumstances be liable for any consequential damages, losses, or expense arising in connection with the use of, or inability to use, the Corporation's product for any purpose whatsoever.

An adjustment made under warranty does not void the warranty, nor does it imply an extension of the original 12-month warranty period. Products serviced and/or parts replaced on a no-charge basis during the warranty period carry the unexpired portion of the original warranty only.

If for any reason any of the foregoing provisions shall be ineffective, the Corporation's liability for damages arising out of its manufacture or sale of equipment, or use thereof, whether such liability is based on warranty, contract, negligence, strict liability in tort, or otherwise, shall not in any event exceed the full purchase price of such equipment.

Any action against the Corporation based upon any liability or obligation arising hereunder or under any law applicable to the sale of equipment or the use thereof, must be commenced within one year after the cause of such action arises.



901 East Thompson Avenue
Glendale, California 91201-2011
Phone: (818) 502-1528
Fax: (818) 502-0716

www.minarikcorp.com
Document number 250-0222, Revision 2
Printed in the U.S.A – June 2002