

XL3300A



User's Manual

Pulse-Width Modulated,
Adjustable Speed, Chassis Drive for
DC Brush Motors

Copyright © 2002 by
Minarik Corporation

All rights reserved. No part of this manual may be reproduced or transmitted in any form without written permission from Minarik Corporation. The information and technical data in this manual are subject to change without notice. Minarik Corporation and its Divisions make no warranty of any kind with respect to this material, including, but not limited to, the implied warranties of its merchantability and fitness for a given purpose. Minarik Corporation and its Divisions assume no responsibility for any errors that may appear in this manual and make no commitment to update or to keep current the information in this manual. MVD102302

Printed in the United States of America.

Safety Warnings



- This symbol  denotes an important safety tip or warning. **Please read these instructions carefully** before performing any of the procedures contained in this manual.
- **DO NOT INSTALL, REMOVE, OR REWIRE THIS EQUIPMENT WITH POWER APPLIED.** Have a qualified electrical technician install, adjust and service this equipment. Follow the National Electrical Code and all other applicable electrical and safety codes, including the provisions of the Occupational Safety and Health Act (OSHA), when installing equipment.
- Reduce the chance of an electrical fire, shock, or explosion by proper grounding, over-current protection, thermal protection, and enclosure. Follow sound maintenance procedures.



It is possible for a drive to run at full speed as a result of a component failure. Minarik strongly recommends the installation of a master switch in the main power input to stop the drive in an emergency.

Circuit potentials are at 115 VAC or 230 VAC above earth ground. Avoid direct contact with the printed circuit board or with circuit elements to prevent the risk of serious injury or fatality. Use a non-metallic screwdriver for adjusting the calibration trimpots. Use approved personal protective equipment and insulated tools if working on this drive with power applied.

Contents

Safety Warnings	i
Specifications	1
Dimensions	2
PC Board Layout	3
Installation	4
Mounting	4
Wiring	6
Shielding guidelines	7
Connections	8
Cage-clamp terminal block	8
Field output	10
Speed adjust potentiometer	11
Fusing	12
Voltage Follower	13
Operation	14
Before applying power	14
Startup	16
Diagnostic LEDs	16
Starting and Stopping Methods	17
Calibration	22
Minimum Speed (MIN SPD)	24
Maximum Speed (MAX SPD)	24
Torque Limit (TORQ LIMIT)	25
Acceleration (ACCEL)	26
Deceleration (DECEL)	27
IR Compensation (IR COMP)	28
JOG	29
Calibration with low voltage DC motors	30

Application Notes	31
Multiple Fixed Speeds	31
Adjustable Speeds using Potentiometers in Series	32
Independent Adjustable Speeds	33
Leader-Follower Application	34
Single Speed Potentiometer Control of Multiple Drives	35
Reversing	36
Reversing with a DLC600 Controller	37
Troubleshooting	38
Before applying power	38
Block Diagrams	42
Replacement Parts	43
Certificate of Compliance	44
AC Line Filters	45
Unconditional Warranty	inside back cover

Tables

Table 1. Field Output Connections	10
Table 2. Recommended Dynamic Brake Resistor Sizes	21
Table 3. Replacement Parts	43
Table 4. AC Line Filters	45

Illustrations

Figure 1. XL3300A Dimensions	2
Figure 2. XL3300A PC Board Layout	3
Figure 3. Earth Ground Screw	5
Figure 4. Cage-Clamp Terminal Block	8
Figure 5. XL3300A Connections	9
Figure 6. Speed Adjust Potentiometer	11
Figure 7. Voltage Follower Connections	13
Figure 8. Voltage Selector Switches	15
Figure 9. Inhibit Pins	18
Figure 10. Run/Decelerate to Minimum Speed Switch	19
Figure 11. Run/Decelerate to Zero Speed Switch	20
Figure 12. Calibration Trimpot Layout	23
Figure 13. XL3300A TORQ. LIMIT and IR COMP Settings	29
Figure 14. XL3300A MAX SPD Settings for Low Voltage DC Motors	30
Figure 15. Multiple Fixed Speeds	31
Figure 16. Adjustable Fixed Speeds Using Potentiometers in Series	32
Figure 17. Independent Adjustable Speeds	33
Figure 18. Independent Forward and Reverse Speeds	34
Figure 19. Single Speed Potentiometer Control of Multiple Drives	35
Figure 20. Independent Forward and Reverse Speeds	36
Figure 21. Independent Forward and Reverse Speeds	37
Figure 22. XL3300A Block Diagram	42

Specifications

Type	open chassis
AC Line Voltage	115 VAC / 230 vac, $\pm 10\%$, 50/60 Hz, single phase
Line Fuse Rating	25A, fast acting
Horsepower Range @ 130 VDC Output	1/4 - 1 1/2 HP
Horsepower Range @ 240 VDC Output	1/4 - 3 HP
Maximum Armature Voltage Range @ 115 VAC Input	45 - 130 VDC
Maximum Armature Voltage Range @ 230 VAC Input	45 - 260 VDC
Minimum Speed Adjustment Range @ 115 VAC Input	0 - 120 VDC
Minimum Speed Adjustment Range @ 230 VAC Input	0 - 120 VDC
Maximum Armature Current	13 ADC
Field Voltage @ 115 VAC Input	50 VDC / 100 VDC
Field Voltage @ 230 VAC Input	100 VDC / 200 VDC
Maximum Field Current	1 ADC
Form Factor	1.05
Acceleration Time Range (no load)	
for 0 - 130 VDC Armature Voltage Range	1 - 9 seconds
for 0 - 240 VDC Armature Voltage Range	1 - 15 seconds
Deceleration Time Range (no load)	
for 0 - 130 VDC Armature Voltage Range	1 - 10 seconds
for 0 - 240 VDC Armature Voltage Range	1 - 18 seconds
Analog Input Voltage Range (isolated signal; S1 to S2)	
for 0 - 130 VDC Armature Voltage Range	0 - 2.5 VDC
for 0 - 240 VDC Armature Voltage Range	0 - 5.0 VDC
Speed Adjust Potentiometer	10K ohms
Approximate Input Impedance (from S1 to S2)	50K ohms
Speed Regulation (at base speed)	0.5%
Ambient Operating Temperature Range	10 ^o - 40 ^o C
Vibration	0.5G max. (0 - 50 Hz) 0.1G max. (above 50 Hz)

Dimensions

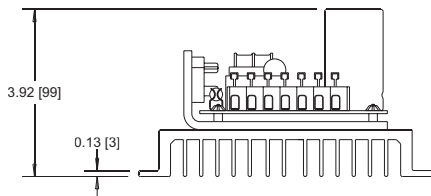
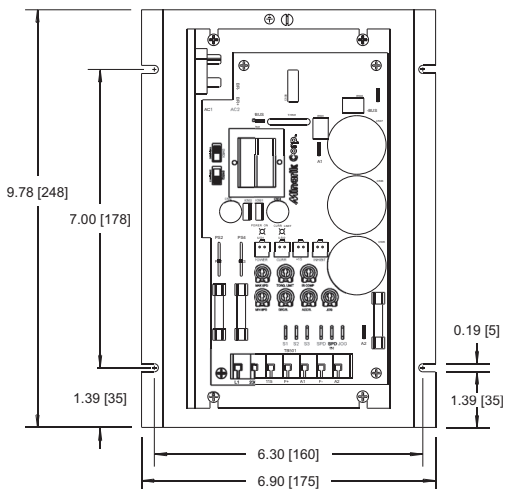

ALL DIMENSIONS IN INCHES [MILLIMETERS]
MOUNTING SLOTS 0.19 X 3.4 [5 X 9]

Figure 1. XL3300A Dimensions

PC Board Layout

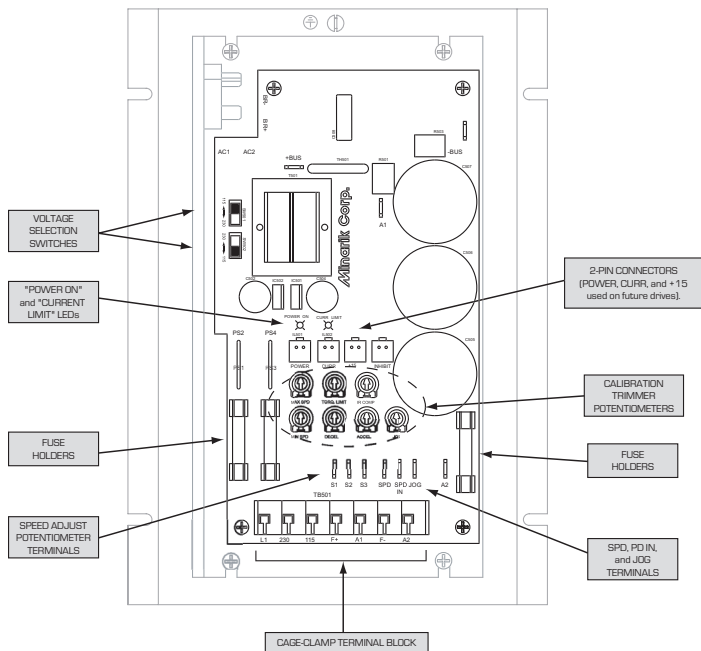

Figure 2. XL3300A PC Board Layout

Installation

Mounting



Warning

Do not install, rewire, or remove this control with input power applied. Doing so may cause fire or serious injury. Make sure you have read and understood the Safety Warnings on page i before attempting installation.

- Drive components are sensitive to electrostatic fields. Avoid direct contact with the circuit board. Hold drive by the chassis only.
- Protect the drive from dirt, moisture, and accidental contact.
- Provide sufficient room for access to the terminal block and calibration trim pots. The minimum enclosure size for the XL3300A is six cubic feet.
- Mount the drive away from heat sources. Operate the drive within the specified ambient operating temperature range.
- Prevent loose connections by avoiding excessive vibration of the drive.
- Mount drive with its board in either a horizontal or vertical plane. Four 0.19 inch (5 mm) wide slots in the chassis accept #8 pan head screws.
- Connect earth ground to the green earth ground screw attached to the heat sink. See Figure 3 (page 5) for the earth ground screw location.

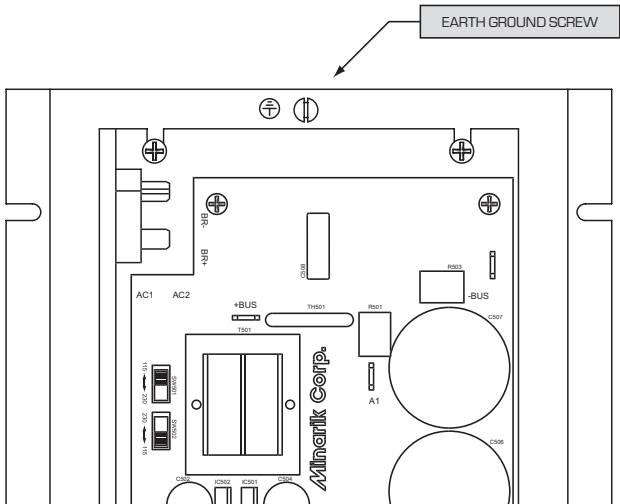

Figure 3. Earth Ground Screw

Wiring



Warning



Do not install, remove, or rewire this equipment with power applied. Failure to heed this warning may result in fire, explosion, or serious injury.

Circuit potentials are at 115 or 230 VAC above ground. To prevent the risk of injury or fatality, avoid direct contact with the printed circuit board or with circuit elements.

Do not disconnect any of the motor leads from the drive unless power is removed and the drive is disabled. Opening any one motor lead may destroy the drive.

- Use 18 AWG wire for speed adjust potentiometer wiring. Use 16 AWG wire for field (F1, F2) wiring. Use 14 AWG wire for AC line (L1, L2) and motor (A1, A2) wiring.

Shielding guidelines



Warning

Under no circumstances should power and logic leads be bundled together. Induced voltage can cause unpredictable behavior in any electronic device, including motor controls.

As a general rule, Minarik recommends shielding of all conductors.

If it is not practical to shield power conductors, Minarik recommends shielding all logic-level leads. If shielding logic leads is not practical, the user should twist all logic leads with themselves to minimize induced noise.

It may be necessary to earth ground the shielded cable. If noise is produced by devices other than the drive, ground the shield at the drive end. If noise is generated by a device on the drive, ground the shield at the end away from the drive. Do not ground both ends of the shield.

If the drive continues to pick up noise after grounding the shield, it may be necessary to add AC line filtering devices, or to mount the drive in a less noisy environment.

Connections

Cage-clamp terminal block

XL3300A connections are made to a cage-clamp terminal block (Figure 4). To insert a wire into the terminal block, press down on the lever arm using a small screwdriver. Insert stripped wire into the large opening in front of the terminal block. Release the lever arm to clamp the wire.

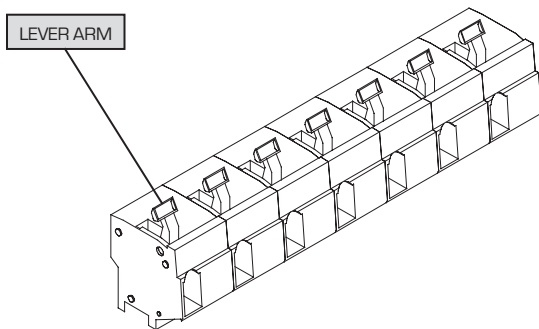

Figure 4. Cage-Clamp Terminal Block

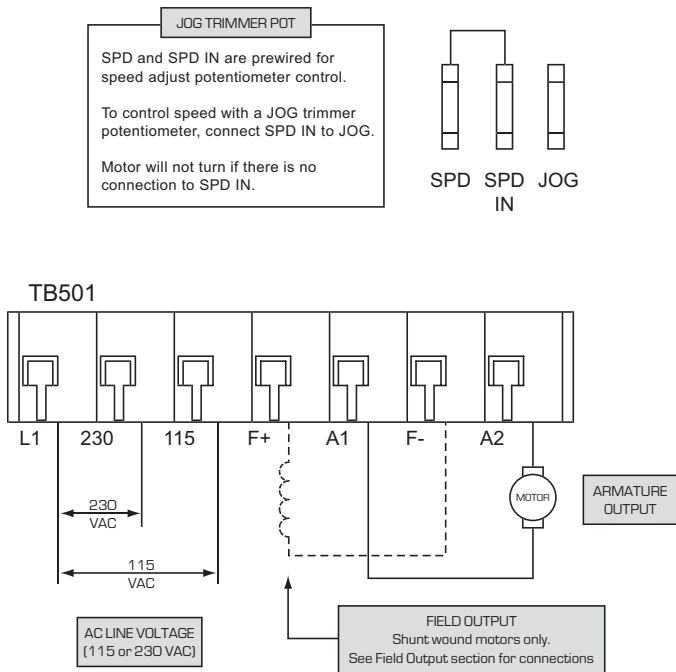

Figure 5. XL3300A Connections

Field output

The field output is for shunt wound motors only. Do not make any connections to the field output when using a permanent magnet motor. Table 1 shows where to connect the field leads of a shunt wound motor.

Table 1. Field Output Connections

Line Voltage (VAC)	Approximate Field Voltage (VDC)	XL3300A Field Connections
115	50	F+ and L1
115	100	F+ and F-
230	100	F+ and L1
230	200	F+ and F-

Use 18 AWG wire to connect the field output to a shunt wound motor.

Speed adjust potentiometer

Install the circular insulating disk between the panel and the 10K ohm speed adjust potentiometer. Mount the speed adjust potentiometer through a 0.38 inches (10 mm) hole with the hardware provided (Figure 6). Twist the speed adjust potentiometer wire to avoid picking up unwanted electrical noise. If potentiometer leads are longer than 18 inches (457 mm), use shielded cable. Ground only one end of the shield.

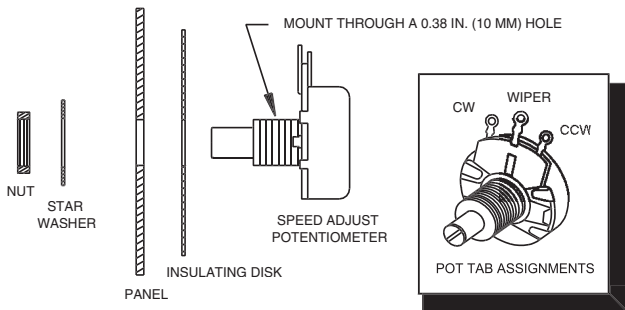

Figure 6. Speed Adjust Potentiometer

Fusing

The XL3300A has three 25A, fast-acting fuses installed (FU501 - FU503). FU501 connects with the L1 terminal (the hot leg of the AC line voltage). FU502 connects with the 230 terminal. FU503 connects with the A2 terminal to protect the motor from related conditions not protected by the AC line fuses. If the horsepower rating of the motor is less than the maximum horsepower rating of the drive, replace the fuse with a lower rated one. Rate fuses at 150% times the maximum armature current.

Operation

Before applying power



Warning

Change voltage selection switch settings only when the drive is disconnected from the AC line voltage. Make sure both switches are set to their correct position. If the switches are improperly set to a lower voltage position, the motor will not run at full voltage. If the switches are improperly set to a higher voltage position, the motor will overspeed, which may cause motor damage.

- Verify that no conductive material is present on the printed circuit board.
- Set both voltage selection switches (SW501 and SW502) to either 115 or 230 to match the AC line voltage being used. See Figure 8 (page 16).

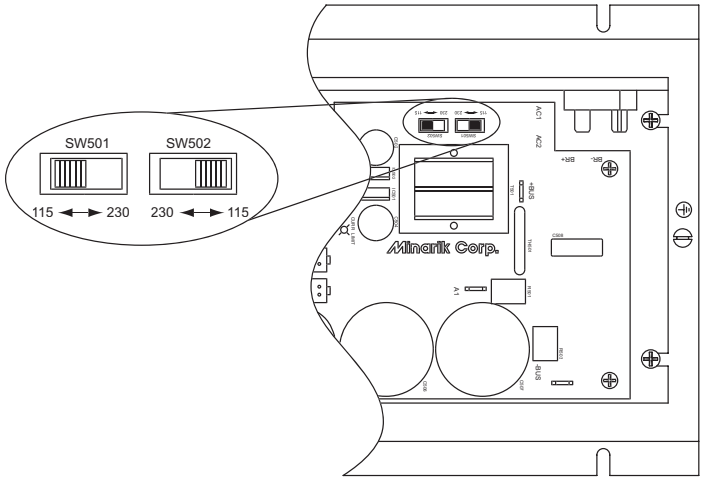

Figure 8. Voltage Selector Switches

Startup

1. Turn the speed adjust potentiometer full counterclockwise (CCW).
2. Apply AC line voltage.
3. Slowly advance the speed adjust potentiometer clockwise (CW). The motor slowly accelerates as the potentiometer is turned CW. Continue until the desired speed is reached.
4. Remove AC line voltage from the drive to coast the motor to a stop.

If the motor or drive does not perform as described, disconnect the AC line voltage immediately. Refer to the *Troubleshooting section* on page 40 for further assistance.

Diagnostic LEDs

XL3300A drives are equipped with the following diagnostic LEDs:

- The green **POWER ON LED** turns on when power is applied to the drive and turns off when power is removed.
- The red **CURR LIMIT LED** turns on when the drive reaches current limit and turns off when the drive is not in current limit (normal operation).

Starting and Stopping Methods

Line starting and line stopping

Line starting and line stopping (applying and removing AC line voltage) is recommended for infrequent starting and stopping of a drive only. When AC line voltage is applied to the drive, the motor accelerates to the speed set by the speed adjust potentiometer. When AC line voltage is removed, the motor coasts to a stop.

Inhibit circuit



Warning

The inhibit circuit is used for frequent starts and stops. It must never be used as an emergency stop. It may not stop a drive that is malfunctioning. Removing AC line power (both L1 and L2) is the only acceptable method for emergency stopping.

The XL3300A has an inhibit circuit that causes the motor to coast to zero speed when the inhibit pins are shorted together. Removing the connection between the inhibit pins allows the motor to accelerate to the speed set by the speed adjust potentiometer (see Figure 9, page 19).

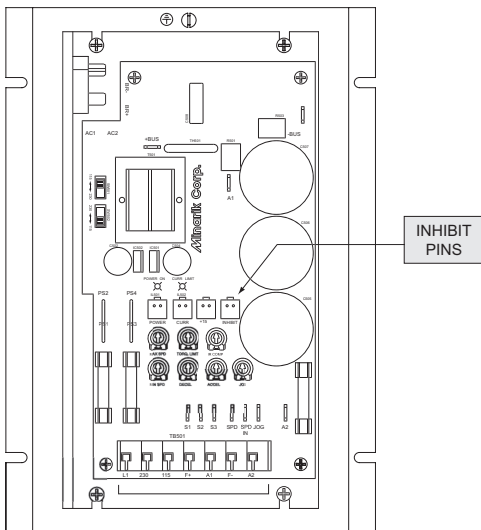

Figure 9. Inhibit Pins

Minarik Corporation offers two accessory plug harnesses for connecting to the inhibit pins: part number 201-0024 [inhibit plug with 18 in. (46 cm) leads]; and part number 201-0079 [inhibit plug with 36 in. (91 cm) leads]. Twist these leads and separate them from other power-carrying wires or sources of electrical noise. Use shielded cable if the inhibit leads are longer than 18 in. (46 cm). If shielded cable is used, ground only one end of the shield to earth ground. Do not ground both ends of the shield.

Decelerating to minimum speed

The circuit shown in Figure 10 may be used to decelerate a motor to a minimum speed. Closing the switch between S1 and S2 decelerates the motor from set speed to a minimum speed determined by the MIN SPD trimpot setting. If the MIN SPD trimpot is set full CCW, the motor decelerates to zero speed when the switch between S1 and S2 is closed. The DECEL trimpot setting determines the rate at which the drive decelerates. By opening the switch, the motor accelerates to set speed at a rate determined by the ACCEL trimpot setting.

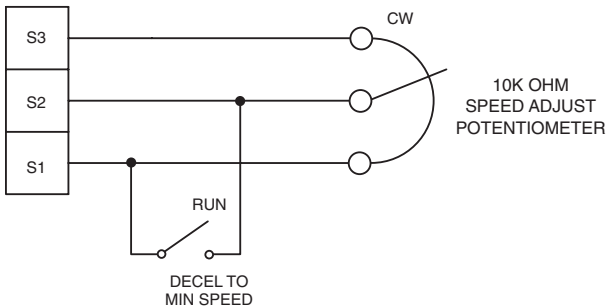

Figure 10. Run/Decelerate to Minimum Speed Switch

Dynamic braking

Dynamic braking may be used to rapidly stop a motor (Figure 11). For the RUN/BRAKE switch, use a double-pole, double-throw switch rated for at least the maximum DC armature voltage and maximum braking current.

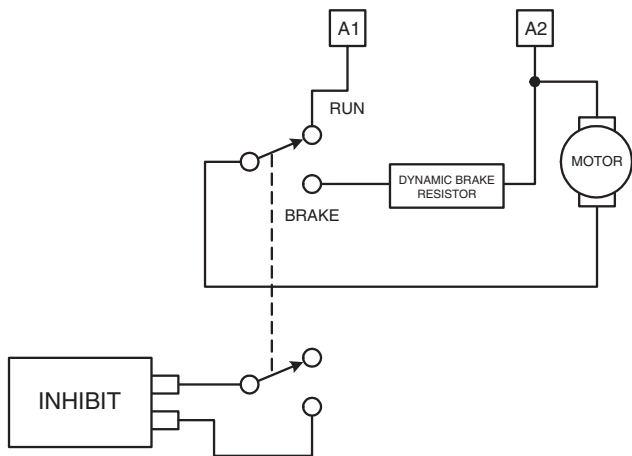

Figure 11. Run/Decelerate to Zero Speed Switch

Size the dynamic brake resistor according to the motor current rating (see Table 2). The dynamic brake resistance listed in the table is the smallest recommended resistance allowed to prevent possible demagnetization of the motor. The motor stops less rapidly with higher brake resistor values.

Table 2. Recommended Dynamic Brake Resistor Sizes

Motor Armature Current Rating (ADC)	Minimum Dynamic Brake Resistor Value (Ohms)	Minimum Dynamic Brake Resistor Power (Watts)
5 - 10	20	20
10 - 17	40	50

Calibration



Warning

Dangerous voltages exist on the drive when it is powered. When possible, disconnect the voltage input from the drive before adjusting the trimpots. If the trimpots must be adjusted with power applied, use insulated tools and the appropriate personal protection equipment. BE ALERT. High voltages can cause serious or fatal injury.

Each drive is factory calibrated to its maximum horsepower rating. Readjust the calibration trimpot settings to accommodate lower current rated motors.

All adjustments increase with CW rotation, and decrease with CCW rotation. Use a non-metallic screwdriver for calibration. Each trimpot is identified on the printed circuit board. See Figure 12 (page 24) for trimmpot locations.

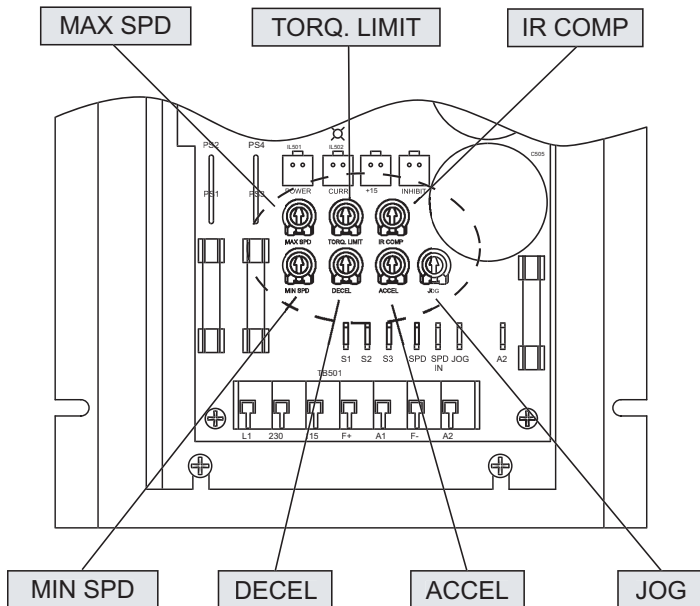

Figure 12. Calibration Trimpot Layout

Minimum Speed (MIN SPD)

The MIN SPD setting determines the motor speed when the speed adjust potentiometer is turned full CCW. It is factory set for minimum rated speed.

To calibrate, set the MIN SPD trimpot full CCW. Turn the speed adjust potentiometer full CCW. Adjust the MIN SPD trimpot until the desired minimum motor speed is reached.

Maximum Speed (MAX SPD)

The MAX SPD setting determines the motor speed when the speed adjust potentiometer is turned full CW. It is factory set for maximum rated speed.

To calibrate, set the MAX SPD trimpot full CCW. Turn the speed adjust potentiometer full CW. Adjust the MAX SPD trimpot until the desired maximum motor speed is reached.

Torque Limit (TORQ LIMIT)



Warning

TORQ. LIMIT should be set to 120% of motor nameplate current rating. Continuous operation beyond this rating may damage the motor. If you intend to operate beyond the rating, contact your Minarik representative for assistance.

The TORQ. LIMIT setting determines the maximum armature current output of the drive. It is factory set at 120% of rated motor current. Recalibrate the TORQ. LIMIT setting when using a lower horsepower motor. Refer to Figure 13 (page 30) for approximate TORQ. LIMIT settings, or recalibrate using the following procedure:

1. With the power disconnected from the control, connect a DC ammeter (0 - 15 minimum scale) in series with the armature.
2. Set the TORQ. LIMIT trimpot to minimum (full CCW).
3. Set the speed adjust potentiometer to maximum speed (full CW).
4. Carefully lock the motor armature. Be sure that the motor is firmly mounted.
5. Apply line power. The motor should be stopped.
6. Slowly adjust the TORQ. LIMIT trimpot CW until the armature current is 120% of motor rated armature current.
7. Turn the speed adjust potentiometer CCW until the motor stops.
8. Remove the line power.
9. Remove the stall from the motor.
10. Remove the ammeter in series with the motor armature if it is no longer needed.

Acceleration (ACCEL)

The ACCEL setting determines the time the motor takes to ramp to a higher speed. See Specifications on page 1 for approximate acceleration times. ACCEL is factory set to its minimum value (full CCW).

Use the following procedure to set the acceleration time:

1. Set the speed adjust potentiometer full CCW. The motor should run at minimum speed (as set by the MIN SPD trimpot, page 25).
2. Turn the speed adjust potentiometer full CW and measure the time it takes the motor to go from minimum to maximum speed.
3. If the time measured in step 2 is not the desired acceleration time, turn the ACCEL trimpot CW for a slower acceleration time, or CCW for a faster acceleration time. Repeat steps 1 through 3 until the acceleration time is correct.

Deceleration (DECEL)

The DECEL setting determines the time the motor takes to ramp to a lower speed. See Specifications on page 1 for approximate deceleration times. DECEL is factory set for the fastest deceleration time (full CCW).

Use the following procedure to set the deceleration time:

1. Set the speed adjust potentiometer full CW. The motor should run at maximum speed (as set by MAX SPD trimpot, page 25).
2. Turn the speed adjust potentiometer full CCW and measure the time it takes the motor to go from maximum to minimum speed.
3. If the time measured in step 2 is not the desired deceleration time, turn the DECEL trimpot CW for a slower deceleration time, or CCW for a faster deceleration time. Repeat steps 1 through 3 until the deceleration time is correct.

IR Compensation (IR COMP)

The IR COMP trimpot setting determines the degree to which motor speed is held constant as the motor load changes. It is factory set for optimum motor regulation.

Recalibrate the IR COMP setting when using a lower current rated motor. Refer to Figure 13 (page 30) for approximate IR COMP settings, or use the following procedure to recalibrate the IR COMP:

1. Set the IR COMP trimpot to minimum (full CCW).
2. Rotate the speed adjust potentiometer until the motor runs at midspeed without load (for example, 900 RPM for an 1800 RPM motor). A hand held tachometer may be used to measure motor speed.
3. Load the motor armature to its full load armature current rating. The motor should slow down.
4. While keeping the load on the motor, rotate the IR COMP trimpot until the motor runs at the speed measured in step 2. If the motor oscillates (overcompensation), the IR COMP trimpot may be set too high (CW). Turn the IR COMP trimpot CCW to stabilize the motor.
5. Unload the motor.

JOG

The JOG setting determines the motor speed when the drive is set to the JOG mode. To control the speed with the JOG trimpot:

1. Connect the SPD IN and JOG terminals.
2. Calibrate the JOG trimpot until the motor runs at the desired JOG speed.

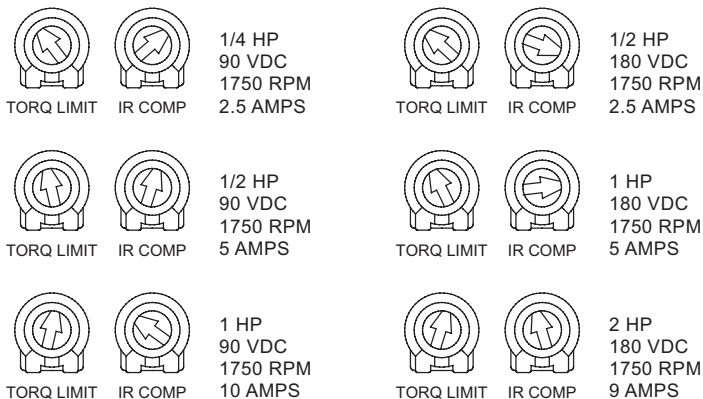

Figure 13. XL3300A TORQ. LIMIT and IR COMP Settings

Calibration with low voltage DC motors

Using XL3300A with a low voltage DC motor requires using a lower resistance speed adjust potentiometer, and recalibrating the MAX SPD trimpot settings. See Figure 14 for MAX SPD trimpot settings.

NOTE: MAX SPD trimmer pot settings are approximate. Verify maximum armature voltage with a voltmeter. Care should be taken when using low voltage motors to ensure motor insulation rating is above bus voltage of the drive.





MOTOR ARMATURE VOLTAGE (VDC)	MAX SPEED TRIMPOT SETTING	
	USING 2.5K OHM SPEED ADJUST POTENTIOMETER (202-0056)	USING 1.5K OHM SPEED ADJUST POTENTIOMETER (202-0001)
12	NOT APPLICABLE	NOT APPLICABLE
24	NOT APPLICABLE	NOT APPLICABLE
36		
48		

Figure 14. XL3300A MAX SPD Settings for Low Voltage DC Motors

Application Notes

Multiple Fixed Speeds

Replace the speed adjust potentiometer with series resistors with a total series resistance of 10K ohms (Figure 15). Add a single-pole, multi-position switch with the correct number of positions for the desired number of fixed speeds.

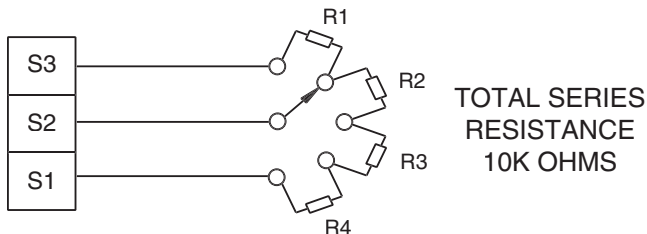

Figure 15. Multiple Fixed Speeds

Adjustable Speeds using Potentiometers in Series

Replace the speed adjust potentiometer with a single-pole, multi-position switch, and two or more potentiometers in series, with a total series resistance of 10K ohms. Figure 16 shows a connection for fixed high and low speed adjust potentiometers.

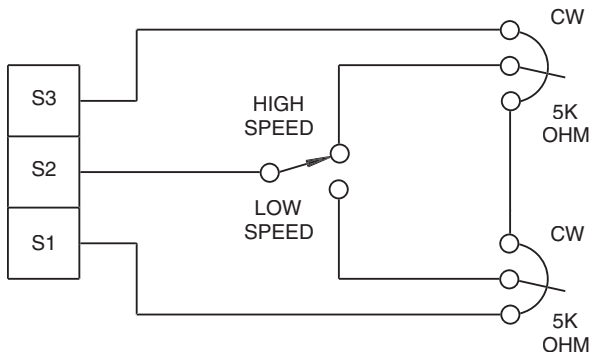

Figure 16. Adjustable Fixed Speeds Using Potentiometers in Series

Independent Adjustable Speeds

Replace the speed adjust potentiometer with a single-pole, multi-position switch, and two or more potentiometers in parallel, with a total parallel resistance of 10K ohms. Figure 17 shows the connection of two independent speed adjust potentiometers that can be mounted at two separate operating stations.

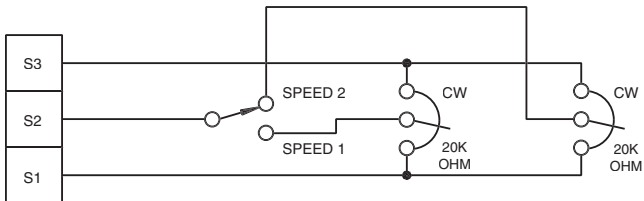

Figure 17. Independent Adjustable Speeds

Leader-Follower Application

In this application, use a PCM4 to monitor the speed of the leader motor (Figure 18). The PCM4 isolates the leader motor from the follower drive, and outputs a voltage proportional to the leader motor armature voltage. The follower drive uses this voltage reference to set the speed of the follower motor. An optional ratio potentiometer may be used to scale the PCM4 output voltage.

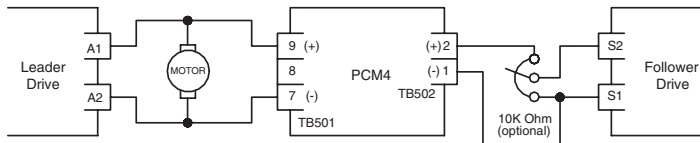

Figure 18. Independent Forward and Reverse Speeds

Single Speed Potentiometer Control of Multiple Drives

Multiple drives can be controlled with a single speed adjust potentiometer using a PCM4 at the input of each drive to provide isolation (Figure 19). Optional ratio potentiometers can be used to scale the PCM4 output voltage, allowing independent control of each drive.

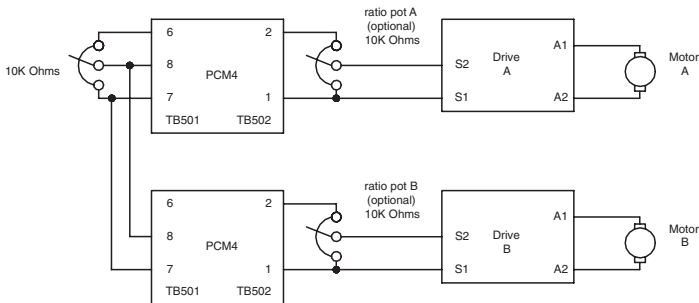

Figure 19. Single Speed Potentiometer Control of Multiple Drives

Reversing

A dynamic brake may be used when reversing the motor direction (Figure 20). Use a three-pole, three-position switch rated for at least the maximum DC armature voltage and maximum braking current. Wait for the motor to stop completely before switching it to either the forward or reverse direction. See page 22 for recommended dynamic brake resistor sizes.

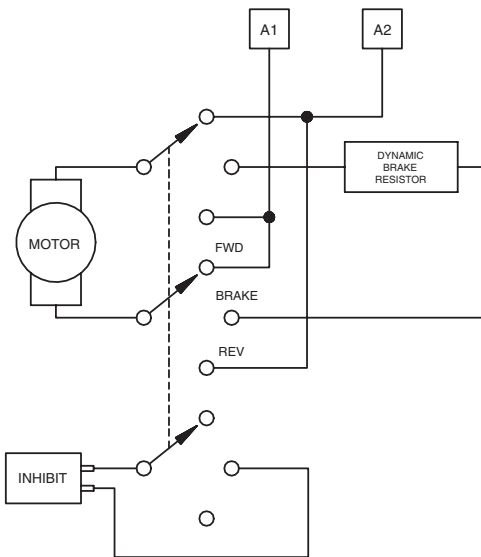

Figure 20. Independent Forward and Reverse Speeds

Troubleshooting



Warning

Dangerous voltages exist on the drive when it is powered. When possible, disconnect the drive while troubleshooting. High voltages can cause serious or fatal injury.

Before applying power

Check the following steps before proceeding:

1. Disconnect AC line voltage from the drive.
2. Check the drive closely for damaged components.
3. Check that no conductive or other foreign material has become lodged on the printed circuit board.
4. Verify that every connection is correct and in good condition.
5. Verify that there are no short circuits or grounded connections.
6. Check that the voltage selection switch settings match the AC line and output voltages.
7. Check that the drive's rated armature and field outputs are consistent with the motor ratings.

For additional assistance, contact your local Minarik distributor, or the factory direct:

1-800-MINARIK (646-2745) or Fax: 1-800-394-6334

Problem	Possible Causes	Suggested Solutions
Line fuse blows.	<ol style="list-style-type: none"> 1. Line fuse is the wrong size. 2. Motor cable or armature is shorted to ground. 	<ol style="list-style-type: none"> 1. Check that the line fuse is correct for the motor size. 2. Check motor cable and armature for shorts.
Line fuse does not blow, but the motor does not run.	<ol style="list-style-type: none"> 1. Speed adjust potentiometer or reference voltage is set to zero speed. 2. Speed adjust potentiometer or reference voltage is not connected to drive input properly; connections are open. 3. INHIBIT terminals are jumpered. 4. S2 is shorted to S0. 	<ol style="list-style-type: none"> 1. Increase the speed adjust potentiometer setting or reference voltage. 2. Check connections to input. Verify that connections are not open. 3. Remove jumper from the INHIBIT terminals. 4. Remove short.

Problem	Possible Causes	Suggested Solutions
Line fuse does not blow, but the motor does not run (cont.)	<ol style="list-style-type: none">5. Drive is in current limit.6. Drive is not receiving AC line voltage.7. Motor is not connected.	<ol style="list-style-type: none">5. The red current limit LED must be off. If the red current limit LED is on, verify that the motor is not jammed. It may be necessary to increase the TORQ. LIMIT setting if it is set to a value lower than the current rating of the motor.6. Apply AC line voltage to L1 and L2.7. Connect motor to A1 and A2.
Motor runs too fast at maximum speed setting	<ol style="list-style-type: none">1. MIN SPD and MAX SPD not calibrated.2. Field output connections are not secure.	<ol style="list-style-type: none">1. Calibrate MIN SPD and MAX SPD . Make sure settings are not set too high.2. Check that the field output connections are secure if you are using a shunt wound motor

Problem	Possible Causes	Suggested Solutions
Motor runs in opposite direction.	1. Connections to motor armature are reversed.	1. Remove AC line voltage and reverse connections to the motor armature.
Motor will not stop when the speed adjust potentiometer is full counterclockwise	1. MIN SPD is not calibrated to zero.	1. Calibrate MIN SPD trimpot to zero speed.
Motor pulsates or surges under load.	1. IR COMP is set too high. 2. Motor bouncing in and out of current limit.	1. Adjust the IR COMP setting slightly CCW until the motor speed stabilizes. 2. Make sure motor is not undersized for load; adjust TORQ LIMIT trimpot CW.

Block Diagrams

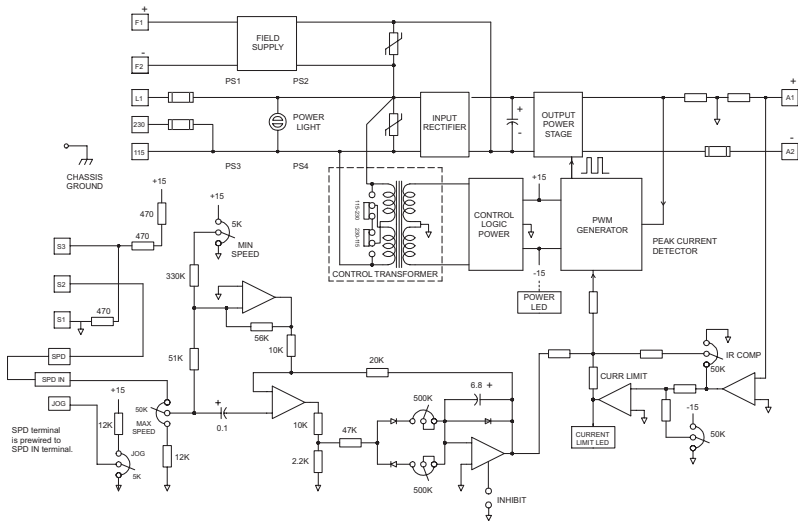

Figure 22. XL3300A Block Diagram

Replacement Parts

Replacement parts are available from Minarik Corporation and its distributors for this drive series.

Table 3. Replacement Parts

Model No.	Symbol	Description	Minarik P/N
XL3300A	BR601	35A, 600V Bridge	073-0008
	C505-507	680 MF, 400 VDC Capacitor	011-0080
	D501	16A, 600V Diode	071-0044
	Q501,502	Power Mosfet	070-0066
	R501	0.01 ohm, 5W Resistor	032-0129
	T501	3FD-436 Transformer	230-0072
	TH501	30A, 1 ohm Thermistor	033-0009
	FU501-503	20A Slow Acting Fuse	050-0063
		10K ohm Potentiometer Kit	202-0003
		Line Fuse Kit (1 - 8A)	050-0068
		Line Fuse Kit (3 - 10A)	050-0070
		Line Fuse Kit (5 - 15A)	050-0072
		1/2A Pico Fuse	050-0064

Certificate of Compliance

Minarik Corporation hereby certifies that its MMRG series drives has been approved to bear the “CE” mark provided the conditions of approval have been met by the end user.

The MMRG series has been tested to the following test specifications:

**EN55011:1993 (emissions), and
EN50082-1:1992 (immunity)**

Compliance allows Minarik’s XL series drives to bear the CE mark.

The end user, as described herein, falls into one of two categories:

1. The Consumer will deploy a stand-alone unit as an integral, yet external, portion of the machine being operated.
2. The Original Equipment Manufacturer (OEM) will implement the product as a component of the machine being manufactured.

AC Line Filters

In addition to EMI/RFI safeguards inherent in the XL series design, external filtering is required.

Minarik requires the AC line filters listed in Table 4. Use model CE15XL with drives rated for 15A AC or below.

Table 4. AC Line Filters

Minarik			
Model Number	CE04XL	CE10XL	CE15XL
Rated Current	4A	10A	15A
Inductance	17.5 mH	14.3 mH	10.0 mH
Capacitance			
Line to Line	0.82 mF	0.82 mF	0.82 mF
Line to Ground	0.0056 mF	0.0056 mF	0.0056 mF
Discharge Resistor	330 Kohms	330 Kohms	330 Kohms

Wire the AC line filter within 0.25 meters of the drive. The ground connection from the filter must be wired to solid earth ground (resistance less than 500 ohms); not machine ground. **This is very important!**

If the end-user is using a CE-approved motor, the correct filter from Table 4 is all that is necessary to meet the EMC directives listed herein.

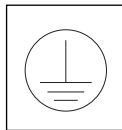

NOTES

NOTES

NOTES

Unconditional Warranty

A. Warranty

Minarik Corporation (referred to as "the Corporation") warrants that its products will be free from defects in workmanship and material for twelve (12) months or 3,000 hours, whichever comes first, from date of manufacture thereof. Within this warranty period, the Corporation will repair or replace, at its sole discretion, such products that are returned to Minarik Corporation, 901 East Thompson Avenue, Glendale, CA 91201-2011 USA.

This warranty applies only to standard catalog products, and does not apply to specials. Any returns for special controls will be evaluated on a case-by-case basis. The Corporation is not responsible for removal, installation, or any other incidental expenses incurred in shipping the product to and from the repair point.

B. Disclaimer

The provisions of Paragraph A are the Corporation's sole obligation and exclude all other warranties of merchantability for use, express or implied. The Corporation further disclaims any responsibility whatsoever to the customer or to any other person for injury to the person or damage or loss of property of value caused by any product that has been subject to misuse, negligence, or accident, or misapplied or modified by unauthorized persons or improperly installed.

C. Limitations of Liability

In the event of any claim for breach of any of the Corporation's obligations, whether express or implied, and particularly of any other claim or breach of warranty contained in Paragraph A, or of any other warranties, express or implied, or claim of liability that might, despite Paragraph B, be decided against the Corporation by lawful authority, the Corporation shall under no circumstances be liable for any consequential damages, losses, or expense arising in connection with the use of, or inability to use, the Corporation's product for any purpose whatsoever.

An adjustment made under warranty does not void the warranty, nor does it imply an extension of the original 12-month warranty period. Products serviced and/or parts replaced on a no-charge basis during the warranty period carry the unexpired portion of the original warranty only.

If for any reason any of the foregoing provisions shall be ineffective, the Corporation's liability for damages arising out of its manufacture or sale of equipment, or use thereof, whether such liability is based on warranty, contract, negligence, strict liability in tort, or otherwise, shall not in any event exceed the full purchase price of such equipment.

Any action against the Corporation based upon any liability or obligation arising hereunder or under any law applicable to the sale of equipment or the use thereof, must be commenced within one year after the cause of such action arises.



901 E Thompson Avenue
Glendale, CA 91201-2011
Tel.: 1-800-MINARIK (646-2745)
Fax: 1-800-394-6334

www.minarikcorp.com
Document Number 250-0217, Rev. 2
Printed in the U.S.A – October 2002