

Excel [XL] Series

Models:

C4XL3025

C4XL3200A



User's Manual

Pulse-Width Modulated, Adjustable Speed,
Cased Drives for DC Brush Motors

Copyright © 2002 by
Minarik Corporation

All rights reserved. No part of this manual may be reproduced or transmitted in any form without written permission from Minarik Corporation. The information and technical data in this manual are subject to change without notice. Minarik Corporation and its Divisions make no warranty of any kind with respect to this material, including, but not limited to, the implied warranties of its merchantability and fitness for a given purpose. Minarik Corporation and its Divisions assume no responsibility for any errors that may appear in this manual and make no commitment to update or to keep current the information in this manual. MVD062402

Printed in the United States of America.

Safety Warnings



- This symbol  denotes an important safety tip or warning. Please read these sections carefully prior to performing any of the instructions contained in that section.
- Have a qualified electrical maintenance technician install, adjust and service this equipment. Follow the National Electrical Code and all other applicable electrical and safety codes, including the provisions of the Occupational Safety and Health Act (OSHA), when installing equipment.
- Reduce the chance of an electrical fire, shock, or explosion by proper grounding, over-current protection, thermal protection, and enclosure. Follow sound maintenance procedures.



It is possible for a drive to run at full speed as a result of a component failure. Minarik strongly recommends the installation of a master switch in the main power input to stop the drive in an emergency.

Circuit potentials are at 115 VAC above earth ground. Avoid direct contact with the printed circuit board or with circuit elements to prevent the risk of serious injury or fatality. Use a non-metallic screwdriver for adjusting the calibration trim pots. Use approved personal protective equipment and insulated tools if working on this drive with power applied.

Contents

Safety Warnings	i
Specifications	1
Dimensions	5
Installation	7
Mounting	7
Connections	9
Shielding guidelines	12
Field Output	13
Fusing	14
Line Fusing for XL Series Drives	15
Voltage Follower	16
Terminal Block	17
Operation	18
Before applying power:	18
Startup	19
Diagnostic LEDs	19
Line starting and line stopping	21
Inhibit circuit	21
Decelerating to minimum speed	23
Dynamic braking	24
Calibration	26
MINIMUM SPEED (MIN SPD)	27
MAXIMUM SPEED (MAX SPD)	27
ACCELERATION (ACCEL)	28
DECELERATION (DECEL)	28
IR COMPENSATION (IR COMP)	29

CURRENT LIMIT (CURR LIMIT) C4XL3025 or	
TORQUE LIMIT (TORQ LIMIT) C4XL3200A	.30
Calibration with low voltage DC motors	.32
Application Notes	.34
Leader-follower application	.34
Single speed potentiometer control of multiple drives	.35
Troubleshooting	.36
Before troubleshooting	.36
Block Diagram	.40
Replacement Parts	.42
Certificate of Compliance	.44
AC Line Filters	.44
Unconditional Warranty	.inside back cover

Tables

Table 1. Field Output Connections	.13
Table 2. Fuse Chart	.15
Table 3. Recommended Dynamic Brake Resistor Sizes	.25
Table 4. AC Line Filters	.45

Illustrations

Figure 1. C4XL3025 Dimensions	5
Figure 2. C4XL3200A Dimensions	6
Figure 3. C4XL3025 Connections	9
Figure 4. C4XL3200A Connections	10
Figure 5. Prewired Connections for Models C4XL3025 and C4XL3200A	11
Figure 6. Voltage Follower Connections	16
Figure 7. Cage-Clamp Terminal	17
Figure 8. Voltage Switch Location	18
Figure 9. Diagnostic LED Location	20
Figure 10. Inhibit Plug with Run/Coast to Zero Speed Switch	22
Figure 11. Run/Decelerate to Minimum Speed Switch	23
Figure 12. Dynamic Brake Connection	24
Figure 13. C4XL3025 CURR LIMIT and IR COMP Settings	31
Figure 14. C4XL3200A TORQ. LIMIT and IR COMP Settings	31
Figure 15. C4XL3025 MAX SPEED Settings for Low Voltage DC Motors	32
Figure 16. C4XL3200A MAX SPD Settings for Low Voltage DC Motors	33
Figure 17. Leader-Follower Application	34
Figure 18. Single Speed Potentiometer Control of Multiple Drives	35
Figure 19. C4XL3025 Series Block Diagram	40
Figure 20. C4XL3200A Block Diagram	41

Specifications

Model Number	C4XL3025
Type:	Cased
NEMA Rating	NEMA 4X
AC Line Voltage	115 VAC/230 VAC, $\pm 10\%$, 50/60 Hz, single phase
Line Fuse Rating	8 A
Horsepower Range @ 130 VDC Output	1/20–1/3 HP
Horsepower Range @ 240 VDC Output	1/8–1/2 HP
Maximum Armature Voltage Range @ 115 VAC Input	50–130 VDC
Maximum Armature Voltage Range @ 230 VAC Input	50–240 VDC
Minimum Speed Adjustment Range @ 115 VAC Input	0–65 VDC
Minimum Speed Adjustment Range @ 230 VAC Input	0–65 VDC
Maximum Armature Current	3 ADC
Field Voltage @ 115 VAC Input	50 VDC/100 VDC
Field Voltage @ 230 VAC Input	100 VDC/200 VDC
Maximum Field Current	1 ADC
Form Factor	1.05
Acceleration Time Range (no load)	
for 0–130 VDC Armature Voltage Range	1–10 seconds
for 0–240 VDC Armature Voltage Range	1–19 seconds
Deceleration Time Range (no load)	
for 0–130 VDC Armature Voltage Range	3–9 seconds
for 0–240 VDC Armature Voltage Range	4–19 seconds
Analog Input Voltage Range (signal must be isolated; S1 to S2)	
for 0–130 VDC Armature Voltage	0–2.7 VDC
for 0–240 VDC Armature Voltage	0–5.0 VDC

Speed Adjustment Potentiometer	10K ohms
Approximate Input Impedance (from S1 to S2)	100K ohms
Speed Regulation (at base speed)	1%
Weight	4.4 lb
Ambient Operating Temperature Range	10°C–40°C
Vibration	0.5g max (0 – 50 Hz) 0.1g max (above 50 Hz)

Model Number	C4XL3200A
Type	Cased
NEMA Rating	NEMA 4X
AC Line Voltage	115 VAC/230 VAC, $\pm 10\%$, 50/60 Hz, single phase
Line Fuse Rating	15 A
Horsepower Range @ 130 VDC Output	1/4–1 HP
Horsepower Range @ 240 VDC Output	1/4–2 HP
Maximum Armature Voltage Range @ 115 VAC Input	50–130 VDC
Maximum Armature Voltage Range @ 230 VAC Input	50–240 VDC
Minimum Speed Adjustment Range @ 115 VAC Input	0–120 VDC
Minimum Speed Adjustment Range @ 230 VAC Input	0–120 VDC
Maximum Armature Current	10 ADC
Field Voltage @ 115 VAC Input	50 VDC/100 VDC
Field Voltage @ 230 VAC Input	100 VDC/200 VDC
Maximum Field Current	1 ADC
Form Factor	1.05
Acceleration Time Range (no load)	
for 0–130 VDC Armature Voltage Range	1–10 seconds
for 0–240 VDC Armature Voltage Range	1–15 seconds
Deceleration Time Range (no load)	
for 0–130 VDC Armature Voltage Range	1–10 seconds
for 0–240 VDC Armature Voltage Range	1–19 seconds
Analog Input Voltage Range (signal must be isolated; S1 to S2)	
for 0–130 VDC Armature Voltage	0–2.7 VDC
for 0–240 VDC Armature Voltage	0–5.0 VDC
Speed Adjustment Potentiometer	10K ohms

Approximate Input Impedance (from S1 to S2)	50K ohms
Speed Regulation (at base speed)	1%
Weight	7.4 lb
Ambient Operating Temperature Range	10°C–40°C
Vibration	0.5g max (0 – 50 Hz) 0.1g max (above 50 Hz)

Dimensions

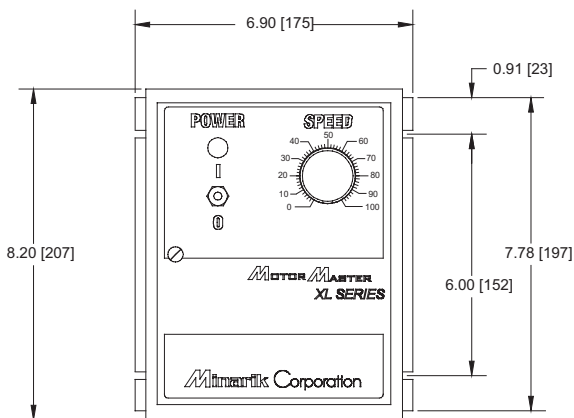

FOUR MOUNTING SLOTS 0.19 [5] WIDE

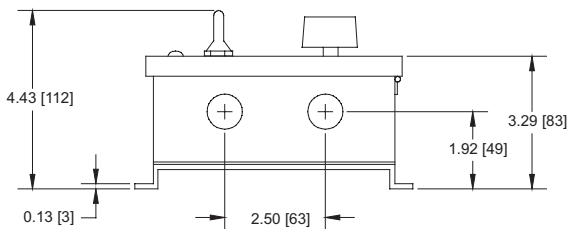

TWO 0.88 [22] KNOCKOUTS

ALL DIMENSIONS IN INCHES [MILLIMETERS]

Figure 1. C4XL3025 Dimensions

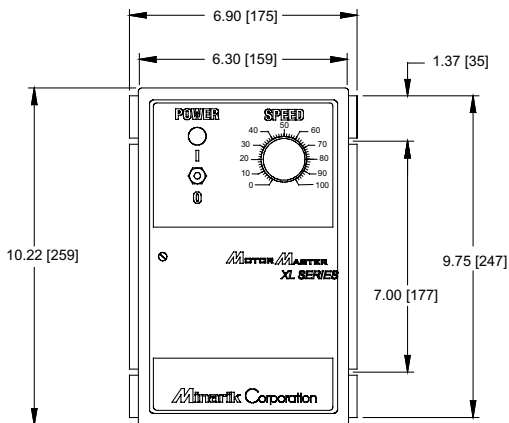

FOUR MOUNTING SLOTS 0.19 [5] WIDE

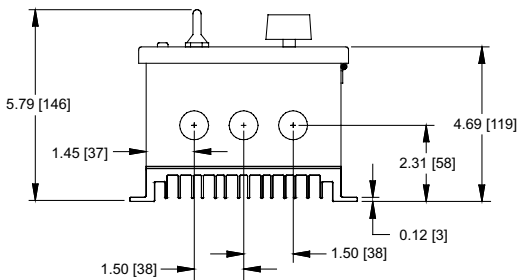

THREE 0.88 [22] KNOCKOUTS

ALL DIMENSIONS IN INCHES [MILLIMETERS]

Figure 2. C4XL3200A Dimensions

Installation

Mounting

Nema 4X cased drives come with 0.88 inch (22 mm) conduit knockout holes at the bottom of the case. The units may be vertically wall mounted using the four 0.19 inch (5 mm) slotted holes on the attached heat sink. For motor loads less than 5 ADC, the drive may be bench mounted horizontally, or operated without mounting.

1. Install the mounting screws through the drive's four mounting slots.
2. For access to the terminal strip, turn the slotted screw on the front cover counterclockwise until it is free from the case. The right side of the cover is hinged to the case. Pull the slotted screw to open the case.
3. Carefully remove the 0.88 inch (22 mm) conduit knockouts by tapping them into the case and twisting them off with pliers.
4. Install conduit hardware through the knockout holes. Connect external wiring to the terminal block.

5. Grasp the slotted screw and tilt the front cover back into place. Avoid pinching any wires between the front cover and the case.
6. Turn the slotted screw clockwise until tight to secure the front cover.
7. Set the POWER switch to the OFF position before applying the AC line voltage.

Connections

Minarik drives supply motor voltage to terminals A1 and A2 (A1 is positive with respect to A2). It is assumed throughout this manual that the driven motor will rotate clockwise (CW) while looking at the output shaft protruding from the front of the motor. If the opposite is desired, simply reverse the wiring of A1 and A2 with each other.

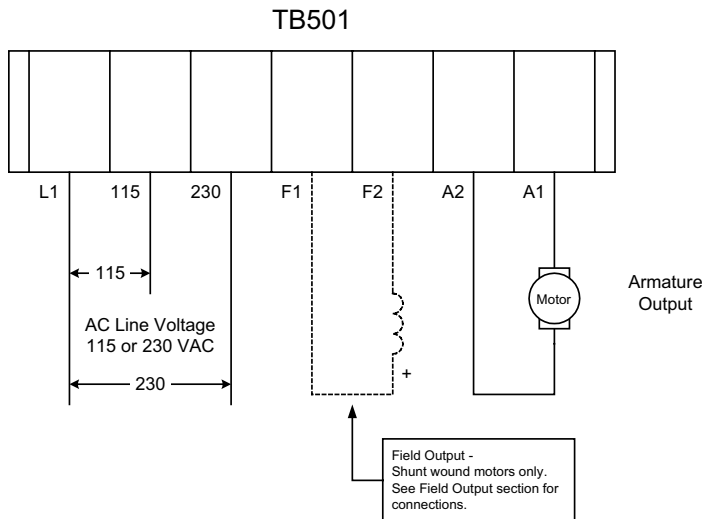

Figure 3. C4XL3025 Connections

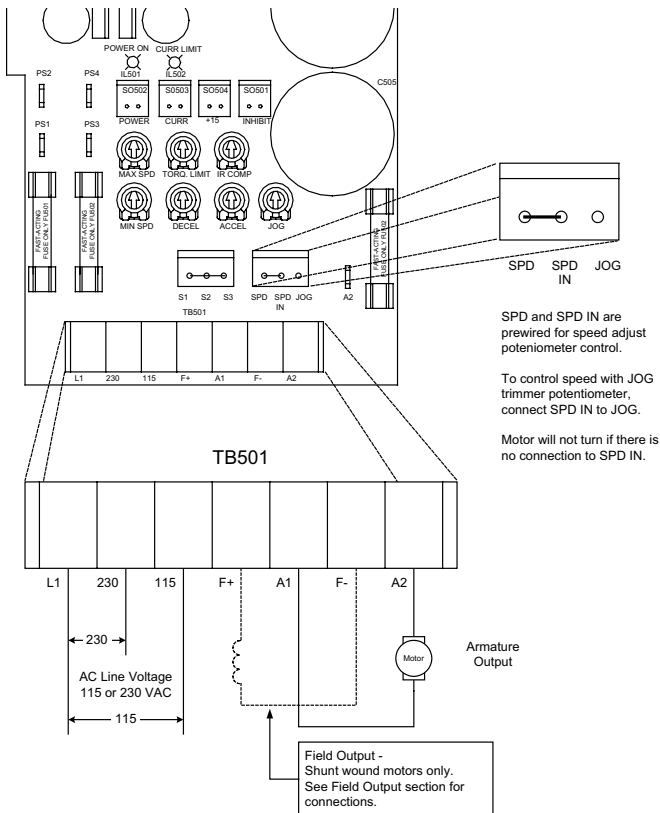

Figure 4. C4XL3200A Connections

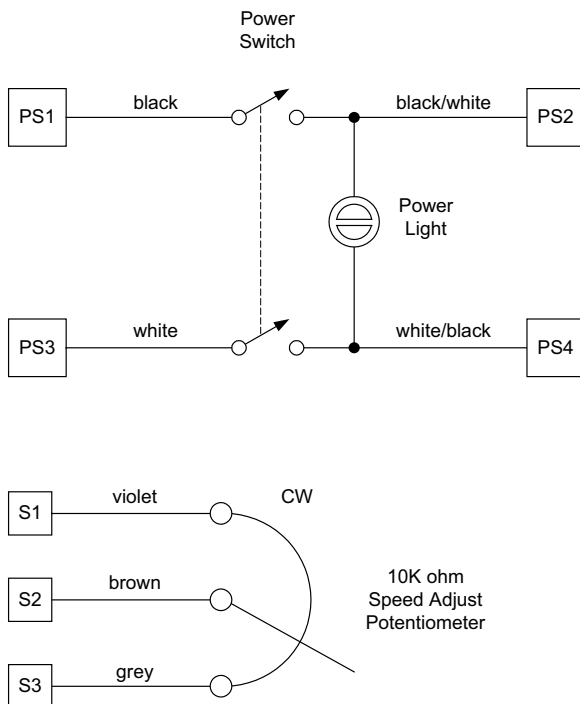

Figure 5. Prewired Connections for Models C4XL3025 and C4XL3200A

Shielding guidelines



Warning

Under no circumstances should power and logic leads be bundled together. Induced voltage can cause unpredictable behavior in any electronic device, including motor controls.

As a general rule, Minarik recommends shielding of all conductors.

If it is not practical to shield power conductors, Minarik recommends shielding all logic-level leads. If shielding is not practical, the user should twist all logic leads with themselves to minimize induced noise.

It may be necessary to earth ground the shielded cable. If noise is produced by devices other than the drive, ground the shield at the drive end. If noise is generated by a device on the drive, ground the shield at the end away from the drive. Do not ground both ends of the shield.

If the drive continues to pick up noise after grounding the shield, it may be necessary to add AC line filtering devices, or to mount the drive in a less noisy environment.

Logic wires from other input devices, such as motion controllers and PLL velocity controllers, must be separated from power lines in the same manner as the logic I/O on this drive.

Field Output

The field output is for shunt wound motors only. Do not make any connections to the field output when using a permanent magnet motor. Table 1 shows where to connect the field leads of a shunt wound motor.

Table 1. Field Output Connections

Line Voltage (VAC)	Approximate Field Voltage (VDC)	C4XL3025 Connections	C4XL3200A Connections
115	50	F1 and L1	F+ and L1
115	100	F1 and F2	F+ and F-
230	100	F1 and L1	F+ and L1
230	200	F1 and F2	F+ and F-

Use 16 AWG wire to connect the field output to a shunt wound motor.

Fusing

C4XL3025: This drive comes with two 8A fuses installed (FU501 and FU502). FU501 connects with the L1 terminal (the hot leg of the AC line voltage). FU502 connects with the 230 terminal. If the current rating of the motor is less than the maximum current rating of the drive, replace the fuse with a lower rated one. Rate fuses at 150% times the maximum armature current.

C4XL3200A: This drives comes with three 15A fuses installed (FU501 - FU503). FU501 connects with the L1 terminal (the hot leg of the AC line voltage). FU502 connects with the 230 terminal. FU503 connects with the A2 terminal to protect the motor from runaway conditions. If the current rating of the motor is less than the maximum current rating of the drive, replace the fuse with a lower rated one. Rate fuses at 150% times the maximum armature current.

Line Fusing for XL Series Drives

Minarik drives require an external fuse for protection. Use fast acting fuses rated for 250 VAC or higher, and approximately 150% of the maximum armature current. Fuse both L1 and L2 when the line voltage is 230 VAC. Fuse blocks are included on cased drives only. The fuse chart below lists the recommended line fuse sizes.

Table 2. Fuse Chart

90 VDC Motor Horsepower	180 VDC Horsepower	Max. DC Armature Current (amps)	AC Line Fuse Size (amps)
1/20	1/10	0.5	1
1/15	1/8	0.8	1.5
1/8	1/4	1.5	3
1/6	1/3	1.7	3
1/4	1/2	2.6	5
1/3	3/4	3.5	8
1/2	1	5.0	10
3/4	1 1/2	7.6	15
1	2	10	15

Minarik Corporation offers a 63 mA pico fuse for the C4XL3025 (part number 050-0081) which protects the transformer and logic.

Voltage Follower

Instead of using a speed adjust potentiometer, the drive may be wired to follow a 0 - 10 VDC voltage signal that is isolated from earth ground (Figure 6). Connect the signal input (+) to S1. Connect the signal common (-) to S2. Make no connection to S3. A potentiometer can be used to scale the analog input voltage. To achieve greater linearity and control, use an interface device such as Minarik model PCM4 to scale the analog input voltage.

Refer to the Specifications section on page 1 for the analog input voltage range of the XL drive you are using.



Figure 6. Voltage Follower Connections

Terminal Block

All XL drives use a cage-clamp spring terminal block. To open the clamp spring, use a small screwdriver to press down on the lever above the terminal block. To insert a wire into a terminal, use the following procedure:

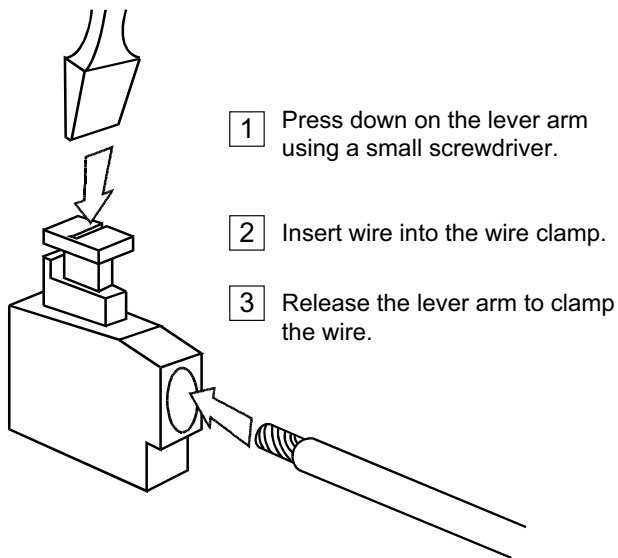

Figure 7. Cage-Clamp Terminal

Operation

Before applying power:

1. Verify that no conductive material is present on the printed circuit board.
2. Set both voltage selection switches (SW501 and SW502) to either 115 or 230 VAC to match the AC line voltage being used. (see Figure 8 below).



Warning

Change voltage selection switch settings only when the drive is disconnected from the AC line voltage. Make sure that both switches are set to the correct position. If the switches are improperly set to a lower voltage position, the motor will not run at full voltage. If the switches are improperly set to a higher voltage position, the motor will over speed, which may cause motor damage.

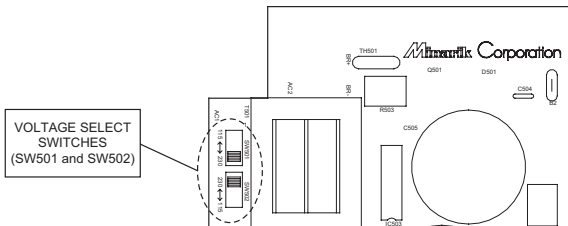

Figure 8. Voltage Switch Location

Startup

1. Set the speed adjust potentiometer to zero (full CCW).
2. Apply AC line voltage.
3. Set the POWER switch to the ON position.
4. Slowly advance the speed adjust potentiometer clockwise (CW).
The motor slowly accelerates as the potentiometer is turned CW. Continue until the desired speed is reached.
5. Set the POWER switch to the OFF position to coast the motor to a stop.

If the motor or drive does not perform as described, disconnect the AC line voltage immediately. Refer to the Troubleshooting section on page 36 for further assistance.

Diagnostic LEDs

XL series drives are equipped with diagnostic LEDs. The green POWER ON LED turns on when power is applied to the drive and turns off when power is removed. The red CURR LIMIT LED turns on when the drive reaches current limit and turns off when the drive is not in current limit (normal operation). See Figure 9 on page 20 for Diagnostic LED locations.

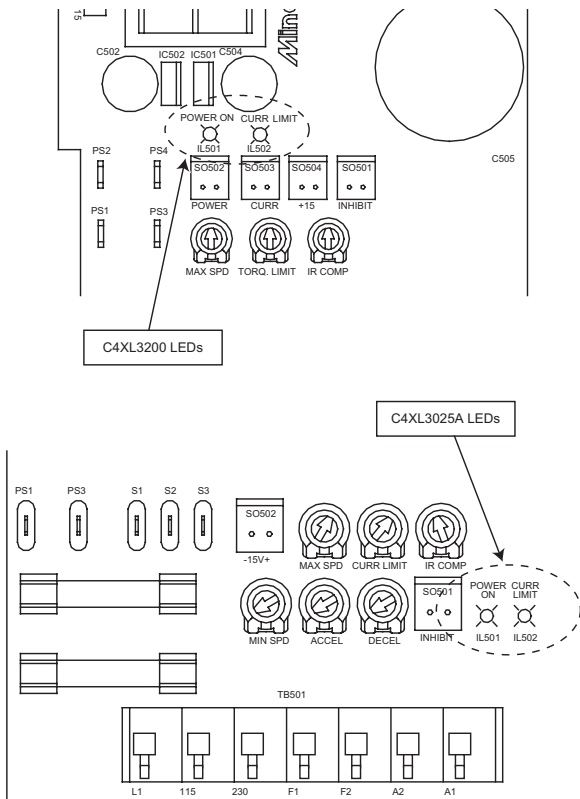

Figure 9. Diagnostic LED Location

Line starting and line stopping

Line starting and line stopping (applying and removing AC line voltage) is recommended for infrequent starting and stopping of a drive only. When AC line voltage is applied to the drive, the motor accelerates to the speed set by the speed adjust potentiometer. When AC line voltage is removed, the motor coasts to a stop.

Inhibit circuit



Warning

The inhibit circuit is used for frequent starts and stops. It must never be used as an emergency stop. The inhibit circuit may not stop a drive that is malfunctioning. Removing AC line power (both L1 and L2) is the only acceptable method for emergency stopping.

Maintaining a connection between the inhibit pins causes the motor to coast to zero speed. Removing the connection between the inhibit pins allows the motor to accelerate the speed set by the speed adjust potentiometer. See Figure 10 on Page 22.

Minarik Corporation offers two accessory plug harnesses for connecting to the inhibit pins: part number 201-0024 [inhibit plug with 18 in. (46 cm) leads]; and part number 201-0079 [inhibit plug with 36 in. (91 cm) leads]. Twist these leads and separate them from other power-carrying wires or sources of electrical noise. Use shielded cable if the inhibit leads are longer than 18 in. (46 cm).

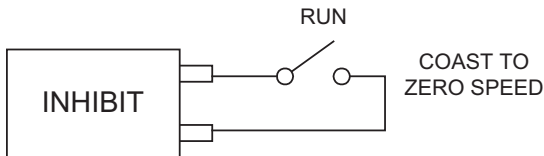

Figure 10. Inhibit Plug with Run/Coast to Zero Speed Switch

Decelerating to minimum speed

The circuit shown in Figure 11 may be used to decelerate a motor to a minimum speed. Closing the switch between S1 and S2 decelerates the motor from set speed to a minimum speed determined by the MIN SPD trimpot setting. If the MIN SPD trimpot is set full CCW, the motor decelerates to zero speed when the switch between S1 and S2 is closed. The DECEL trimpot setting determines the rate at which the drive decelerates. By opening the switch, the motor accelerates to set speed at a rate determined by the ACCEL trimpot setting.

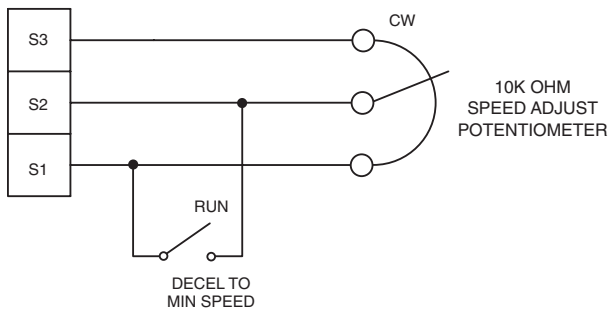

Figure 11. Run/Decelerate to Minimum Speed Switch

Dynamic braking

Dynamic braking may be used to rapidly stop a motor (Figure 12). For the RUN/BRAKE switch, use a double pole, double throw switch rated for at least the maximum DC armature voltage and maximum braking current.

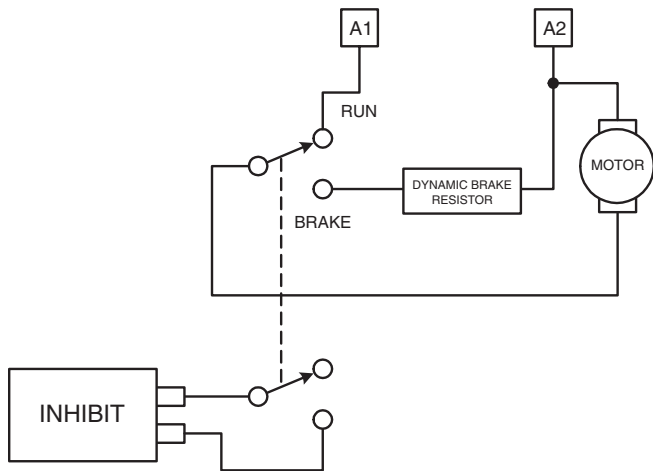

Figure 12. Dynamic Brake Connection



Warning

Wait for the motor to come to a complete STOP before switching back to the RUN position. This will prevent high armature currents from damaging the motor or drive.

Size the dynamic brake resistor according to the motor current rating (see Table 3). The dynamic brake resistance listed in the table is the smallest recommended resistance allowed to prevent possible demagnetization of the motor. The motor stops less rapidly with higher brake resistor values.

Table 3. Recommended Dynamic Brake Resistor Sizes

Minimum Motor Armature Current Rating	Minimum Dynamic Brake Resistor Value	Dynamic Brake Resistor Wattage
Less than 2 ADC	1 ohm	1W
2–3 ADC	5 ohm	5W
3–5 ADC	10 ohm	10W
5–10 ADC	20 ohm	20W
10–17 ADC	40 ohm	50W

For motors rated $1/17$ horsepower and lower, a brake resistor is not necessary since the armature resistance is high enough to stop the motor without demagnetization. Replace the dynamic brake with 12 gauge wire.

Calibration



Warning

Dangerous voltages exist on the drive when it is powered, and up to 30 seconds after power is removed and the motor stops. When possible, disconnect the voltage input from the drive before adjusting the trimpots. If the trimpots must be adjusted with power applied, use insulated tools and the appropriate personal protection equipment. **BE ALERT.** High voltages can cause serious or fatal injury.

Each drive is factory calibrated to its maximum current rating. Readjust the calibration trimpot settings to accommodate lower current rated motors.

All adjustments increase with CW rotation, and decrease with CCW rotation. Use a non-metallic screwdriver for calibration. Each trimpot is identified on the printed circuit board.

MINIMUM SPEED (MIN SPD)

The MIN SPD setting determines the motor speed when the speed adjust potentiometer is turned full CCW. It is factory set to zero speed.

To calibrate, turn the speed adjust potentiometer full CCW. To set the minimum speed to zero, rotate the MIN SPD trimpot CCW until the motor has stopped. To set a minimum speed higher than zero, rotate the MIN SPD trimpot CW until the motor is running at the desired minimum speed.

MAXIMUM SPEED (MAX SPD)

The MAX SPD setting determines the motor speed when the speed adjust potentiometer is turned full CW. It is factory set for maximum rated speed.

To calibrate, set the MAX SPD trimpot full CCW. Turn the speed adjust potentiometer full CW. Adjust the MAX SPD trimpot until the desired maximum motor speed is reached.

Note: Check the MIN SPD and MAX SPD adjustments after recalibrating to verify that the motor runs at the desired minimum and maximum speed.

ACCELERATION (ACCEL)

The ACCEL setting determines the time the motor takes to ramp to a higher speed. See Specifications on page 1 for approximate acceleration times. The ACCEL setting is factory set to its minimum value (full CCW).

Turn the ACCEL trimpot CW to increase the acceleration time, and CCW to decrease the acceleration time.

DECELERATION (DECEL)

The DECEL setting determines the time the motor takes to ramp to a lower speed. See Specifications on page 1 for approximate deceleration times. The DECEL setting is factory set to its minimum value (full CCW).

Turn the DECEL trimpot CW to increase the deceleration time, and CCW to decrease the deceleration time.

IR COMPENSATION (IR COMP)

The IR COMP setting determines the degree to which motor speed is held constant as the motor load changes. It is factory set for optimum motor regulation.

Recalibrate the IR COMP setting when using a lower horsepower motor. Refer to the recommended IR COMP settings in Figure 13 or 14 on Page 31, or recalibrate using the following procedure:

To calibrate IR COMP (exact calibration):

1. Set the speed adjust potentiometer until the motor runs at midspeed
(for example, 900 RPM for an 1800 RPM motor).
2. Load the motor armature to its full load armature current rating.
The motor should slow down.
3. While keeping the load on the motor, rotate the IR COMP trimpot until the motor runs at the speed measured in step 1.

Approximate calibration: If the motor does not maintain set speed as the load changes, gradually rotate the IR COMP trimpot CW. If the motor oscillates (overcompensation), the IR COMP trimpot may be set too high (CW). Turn the IR COMP trimpot CCW to stabilize the motor speed.

CURRENT LIMIT (CURR LIMIT) C4XL3025 or TORQUE LIMIT (TORQ LIMIT) C4XL3200A



Warning

Although TORQUE LIMIT is set to 120% of motor nameplate current rating, continuous operation beyond that rating may damage the motor. If you intend to operate beyond the rating, contact your Minarik representative for assistance.

The CURR LIMIT or TORQ LIMIT setting determines the maximum armature current output of the drive. It is factory set at 120% of rated motor current. Recalibrate the CURR LIMIT or TORQ LIMIT setting when using a lower horsepower motor. Refer to the recommended trimpot settings on page 31, or recalibrate using the following procedure:

1. With the power disconnected from the control, connect a DC ammeter (0 - 15 A minimum scale) in series with the armature.
2. Set the CURR LIMIT or TORQ LIMIT trimpot to minimum (full CCW).
3. Set the speed adjust potentiometer to maximum (full CW).
4. Lock the motor armature. Be sure that the motor is firmly mounted.
5. Connect power to the drive. The motor should remain stopped.
6. Adjust the CURR LIMIT or TORQ LIMIT trimpot CW slowly until armature current is 120% of motor rated current.
7. Set the speed adjust potentiometer to minimum.
8. Remove power.
9. Remove the stall from the motor.

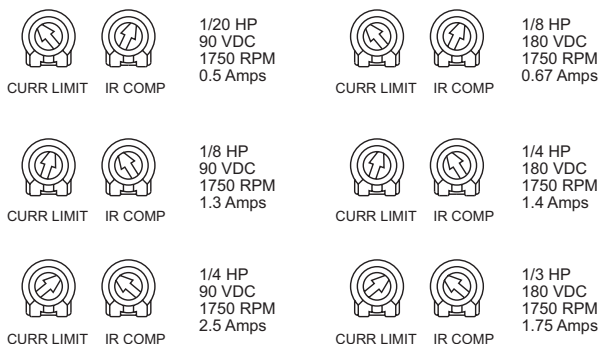

Figure 13. C4XL3025 CURR LIMIT and IR COMP Settings

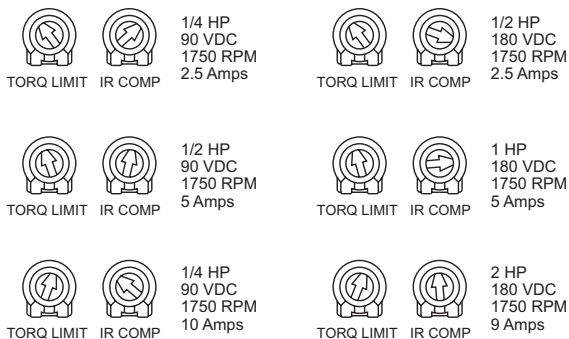

Figure 14. C4XL3200A TORQ. LIMIT and IR COMP Settings

Calibration with low voltage DC motors

Using an XL series drive with a low voltage DC motor requires using a lower resistance speed adjust potentiometer, and recalibrating the MAX SPEED trimpot settings. See Figure 15 below and Figure 16 on page 34 for MAX SPEED trimpot settings.

NOTE: MAX SPEED trimpot settings are approximate. Verify maximum armature voltage with a voltmeter.













MOTOR ARMATURE VOLTAGE (VDC)	MAX SPEED TRIMPOT SETTING	
	USING 2.5K OHM SPEED ADJUST POTENTIOMETER (202-0056)	USING 1.5K OHM SPEED ADJUST POTENTIOMETER (202-0001)
12		
24		
36		
48		

Figure 15. C4XL3025 MAX SPEED Settings for Low Voltage DC Motors

MOTOR ARMATURE VOLTAGE (VDC)	MAX SPEED TRIMPOT SETTING	
	USING 2.5K OHM SPEED ADJUST POTENTIOMETER (202-0056)	USING 1.5K OHM SPEED ADJUST POTENTIOMETER (202-0001)
12	NOT APPLICABLE	NOT APPLICABLE
24	NOT APPLICABLE	NOT APPLICABLE
36		
48		

**Figure 16. C4XL3200A MAX SPD Settings for
Low Voltage DC Motors**

Application Notes

Leader-follower application

In this application, use a PCM4 to monitor the speed of the leader motor (Figure 17). The PCM4 isolates the leader motor from the follower drive, and outputs a voltage proportional to the leader motor armature voltage. The follower drive uses this voltage reference to set the speed of the follower motor. An optional ratio potentiometer may be used to scale the PCM4 output voltage.

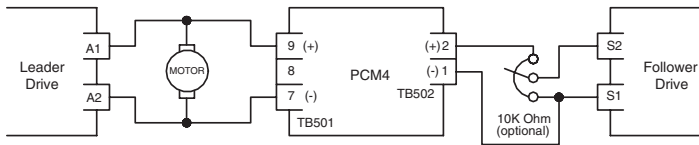

Figure 17. Leader-Follower Application

Single speed potentiometer control of multiple drives

Multiple drives can be controlled with a single speed adjust potentiometer using a PCM4 at the input of each drive to provide isolation (Figure 18). Optional ratio potentiometers can be used to scale the PCM4 output voltage, allowing independent control of each drive.

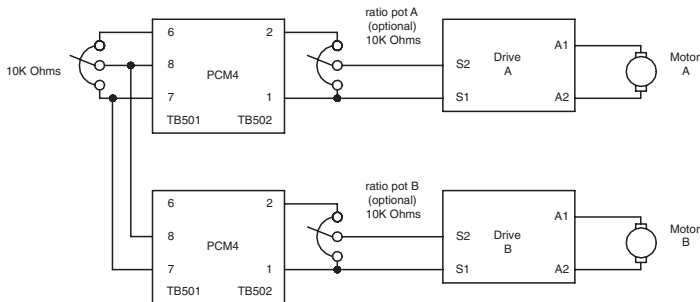

Figure 18. Single Speed Potentiometer Control of Multiple Drives

Troubleshooting



Warning

Dangerous voltages exist on the drive when it is powered, and up to 30 seconds after power is removed and the motor stops. When possible, disconnect the AC line voltage from the drive while troubleshooting. Be alert. High voltages can cause serious or fatal injury.

Before troubleshooting

Perform the following steps before starting any procedure in this section:

1. Disconnect AC line voltage from the drive.
2. Check the drive closely for damaged components.
3. Check that no conductive or other foreign material is lodged on the printed circuit board.
4. Verify that every connection is correct and in good condition.
5. Verify that there are no short circuits or grounded connections.
6. Check that the voltage selection switch settings match the AC line and output voltages.

Problem	Possible Causes	Suggested Solutions
Line fuse blows	<ol style="list-style-type: none">1. Line fuses are the wrong size.2. Motor cable or armature is shorted to ground.3. Nuisance tripping caused by a combination of ambient conditions and high-current spikes (i.e. reversing).	<ol style="list-style-type: none">1. Check that line fuses are the correct size.2. Check motor cable and armature for shorts.3. Add a blower to cool the drive components; increase CURR LIMIT or TORQ LIMIT settings.
Motor runs too fast at maximum speed setting	<ol style="list-style-type: none">1. MIN SPD and MAX SPD settings are too high.	<ol style="list-style-type: none">1. Recalibrate MIN SPD and MAX SPD.

Problem	Possible Causes	Suggested Solutions
Line fuse is not blown, but the motor does not run	<ol style="list-style-type: none"><li data-bbox="366 207 637 365">1. Speed adjust potentiometer, or voltage input signal is set to zero speed.<li data-bbox="366 400 624 615">2. Speed adjust pot, or voltage input signal, is not connected to drive input properly; connections are open.<li data-bbox="366 655 591 711">3. S2 is shorted to S0.<li data-bbox="366 751 615 808">4. Drive is in current limit.<li data-bbox="366 1005 605 1093">5. Drive is not receiving AC line voltage.<li data-bbox="366 1133 544 1189">6. Motor is not connected.	<ol style="list-style-type: none"><li data-bbox="670 207 938 330">1. Increase the speed adjust potentiometer, or voltage setting.<li data-bbox="670 400 935 522">2. Check connections to input. Verify that connections are not open.<li data-bbox="670 655 881 685">3. Remove short.<li data-bbox="670 751 941 931">4. Verify that motor is not jammed. Increase the TORQ or CURR LIMIT setting. It may be set too low.<li data-bbox="670 1005 915 1093">5. Apply AC line voltage to L1 and L2.<li data-bbox="670 1133 915 1189">6. Connect motor to A1 and A2.

Problem	Possible Causes	Suggested Solutions
Motor runs too slow or too fast	1. MIN SPD and MAX SPD not calibrated.	1. Calibrate MIN SPD and MAX SPD.
Motor will not reach the desired speed	1. MAX SPD setting is too low. 2. IR COMP setting is too low. 3. Motor is overloaded.	1. Increase MAX SPD setting. 2. Increase the IR COMP setting. 3. Check motor load. Resize the motor and drive if necessary.
Motor pulsates or surges under load	1. IR COMP is set too high. 2. Motor "bouncing" in and out of torque limit.	1. Adjust the IR COMP setting slightly CCW until the motor speed stabilizes. 2. Make sure motor is not undersized for load; adjust the CURR or TORQ LIMIT trimpot.

Block Diagram

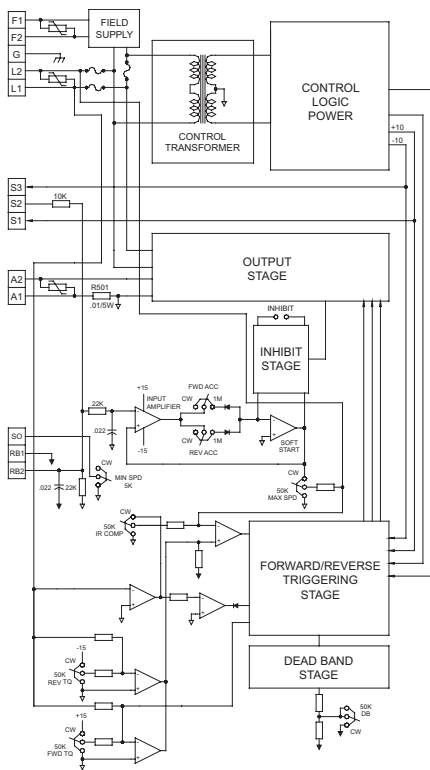

Figure 19. C4XL3025 Series Block Diagram

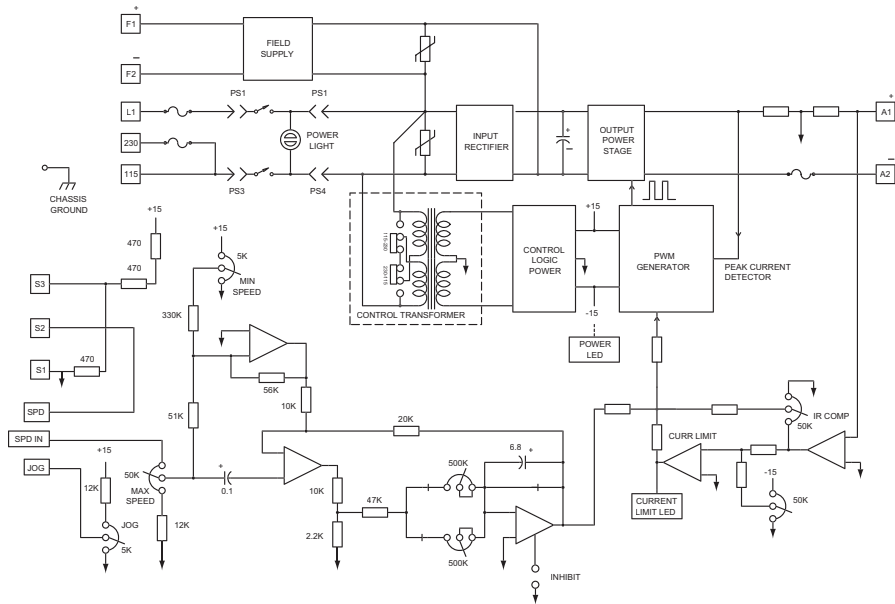

Figure 20. C4XL3200A Block Diagram

Replacement Parts

Replacement parts are available from Minarik Corporation and its distributors for this drive series.

Model No.	Symbol	Description	Minarik P/N
C4XL3025	BR601	25 A, 600 V Bridge	073-0011
	C506	470 MF, 400 VDC Capacitor	010-0075
	D501	8A, 600V Diode	071-0055
	Q501	IGBT Module	070-0051
	R501,502	0.05 ohm, 5 W Resistor	032-0113
	T501	3FD-436 Transformer	230-0072
	TH501	WS380 15A I _{max} Limiter	033-0006
	FU501,502	8 A, 3 AB Normal-Blo Fuse	050-0023
	Pot	10K ohm, ½ W Potentiometer	120-0032
		Knob	140-0013
		240 V Pilot Light	040-0005
		DPST Power Switch	080-0011
		Power Switch Boot	155-0050
		Heat Sink	223-0280
		Case	223-0104
		Line Fuse Kit (1 – 8A)	050-0068
		Line Fuse Kit (3 – 10A)	050-0070
		Line Fuse Kit (5 – 15A)	050-0072
		1/2A Pico fuse	050-0064

Model No.	Symbol	Description	Minarik P/N
C4XL3200A	BR601	35 A, 600 V Bridge	073-0008
	C505-507	680 MF, 400 VDC Capacitor	011-0080
	D501	FES16FT Diode	071-0054
	Q501,502	Power Mosfet	070-0066
	R501	0.01 ohm, 5 W Resistor	032-0129
	T501	3FD-436 Transformer	230-0072
	TH501	30A, 1 ohm Thermistor	033-0009
	FU501-502	15 A, 3 AB Normal-Blo Fuse	050-0018
	pot	10K ohm, 5 W Potentiometer	120-0009
		Knob	140-0013
		240 V Pilot Light	040-0005
		DPST Power Switch	080-0011
		Power Switch Boot	155-0050
		Heat Sink	223-0290
	Case	223-0209	
	1/2A Pico fuse	050-0074	

Certificate of Compliance

Minarik Corporation hereby certifies that its XL series drives (models C4XL3025 and C4XL3200A) have been approved to bear the “CE” mark provided the conditions of approval have been met by the end user.

The XL series has been tested to the following test specifications:

EN55014:1993 (emissions), and
EN50082-1:1992 (immunity)

Compliance allows Minarik’s XL series to bear the CE mark.

The end user, as described herein, falls into one of two categories:

1. The Consumer will deploy a stand-alone unit as an integral, yet external, portion of the machine being operated.
2. The Original Equipment Manufacturer (OEM) will implement the product as a component of the machine being manufactured.

AC Line Filters

In addition to EMI/RFI safeguards inherent in the XL series’ design, external filtering is required.

Minarik requires the AC line filters listed in Table 4. Use model CE04XL with drives rated for 3A AC or below, model CE10XL with drives rated for 10A AC or below, and model CE15XL for drives rated 15A AC or below.

Table 4. AC Line Filters

Minarik Model Number	CE04XL	CE10XL	CE15XL
Rated Current	4 A	10 A	15A
Inductance	17.5 mH	14.3 mH	10.0mH
Capacitance			
Line to Line	0.82 mF	0.82 mF	0.82 mF
Line to Ground	0.0056 mF	0.0056 mF	0.0056 mF
Discharge Resistor	330 KW	330 KW	330 KW

Wire the AC line filter within 0.25 meters of the drive. The ground connection from the filter must be wired to solid earth ground (resistance less than 500 ohms); not machine ground. This is very important!

If the end-user is using a CE-approved motor, the correct filter from Table 4 is all that is necessary to meet the EMC directives listed herein.

NOTES

Unconditional Warranty

A. Warranty - Minarik Corporation (referred to as “the Corporation”) warrants that its products will be free from defects in workmanship and material for twelve (12) months or 3,000 hours, whichever comes first, from date of manufacture thereof. Within this warranty period, the Corporation will repair or replace, at its sole discretion, such products that are returned to Minarik Corporation, 901 East Thompson Avenue, Glendale, CA 91201-2011 USA.

This warranty applies only to standard catalog products, and does not apply to specials. Any returns for special controls will be evaluated on a case-by-case basis. The Corporation is not responsible for removal, installation, or any other incidental expenses incurred in shipping the product to and from the repair point.

B. Disclaimer - The provisions of Paragraph A are the Corporation’s sole obligation and exclude all other warranties of merchantability for use, express or implied. The Corporation further disclaims any responsibility whatsoever to the customer or to any other person for injury to the person or damage or loss of property of value caused by any product that has been subject to misuse, negligence, or accident, or misapplied or modified by unauthorized persons or improperly installed.

C. Limitations of Liability - In the event of any claim for breach of any of the Corporation’s obligations, whether express or implied, and particularly of any other claim or breach of warranty contained in Paragraph A, or of any other warranties, express or implied, or claim of liability that might, despite Paragraph B, be decided against the Corporation by lawful authority, the Corporation shall under no circumstances be liable for any consequential damages, losses, or expense arising in connection with the use of, or inability to use, the Corporation’s product for any purpose whatsoever.

An adjustment made under warranty does not void the warranty, nor does it imply an extension of the original 12-month warranty period. Products serviced and/or parts replaced on a no-charge basis during the warranty period carry the unexpired portion of the original warranty only.

If for any reason any of the foregoing provisions shall be ineffective, the Corporation’s liability for damages arising out of its manufacture or sale of equipment, or use thereof, whether such liability is based on warranty, contract, negligence, strict liability in tort, or otherwise, shall not in any event exceed the full purchase price of such equipment.

Any action against the Corporation based upon any liability or obligation arising hereunder or under any law applicable to the sale of equipment or the use thereof, must be commenced within one year after the cause of such action arises.



901 East Thompson Avenue
Glendale, California 91201-2011
Phone: (800) MINARIK or (800) 646-2745
Fax: (800) 394-6334
www.minarikcorp.com
Document Number 250-0207, Revision 3
Printed in the U.S.A – June 2002