

# MM30000 Series

**Models:**

**MM31002A**

**MM31610A**

**MM32002A**

SCR, Adjustable Speed Drives  
for DC Brush Motors

**User's Manual**

Copyright © 2001 by  
Minarik Corporation

All rights reserved. No part of this manual may be reproduced or transmitted in any form without written permission from Minarik Corporation. The information and technical data in this manual are subject to change without notice. Minarik Corporation and its Divisions make no warranty of any kind with respect to this material, including, but not limited to, the implied warranties of its merchantability and fitness for a given purpose. Minarik Corporation and its Divisions assume no responsibility for any errors that may appear in this manual and make no commitment to update or to keep current the information in this manual.

Printed in the United States of America.

# Safety Warnings



- This symbol  denotes an important safety tip or warning. **Please read these instructions carefully** before performing any of the procedures contained in this manual.
- **DO NOT INSTALL, REMOVE, OR REWIRE THIS EQUIPMENT WITH POWER APPLIED.** Have a qualified electrical technician install, adjust and service this equipment. Follow the National Electrical Code and all other applicable electrical and safety codes, including the provisions of the Occupational Safety and Health Act (OSHA), when installing equipment.
- Reduce the chance of an electrical fire, shock, or explosion by proper grounding, over-current protection, thermal protection, and enclosure. Follow sound maintenance procedures.



**It is possible for a drive to run at full speed as a result of a component failure.** Minarik strongly recommends the installation of a master switch in the main power input to stop the drive in an emergency.

**Circuit potentials are at 115 VAC or 230 VAC above earth ground.** Avoid direct contact with the printed circuit board or with circuit elements to prevent the risk of serious injury or fatality. Use a non-metallic screwdriver for adjusting the calibration trimpots. Use approved personal protective equipment and insulated tools if working on this drive with power applied.

---

# Contents

<b>Specifications</b>	<b>1</b>
<b>Dimensions</b>	<b>2</b>
<b>Installation</b>	<b>6</b>
Mounting	6
Wiring	7
Shielding guidelines	8
Speed adjust potentiometer connections	9
Field output	10
Heat sinking	10
Line fusing	11
Connections	12
MM31002A and MM32002A series drives	12
MM31600A series drives	16
<b>Operation</b>	<b>20</b>
Before applying power	20
Drive startup and shutdown	20
To shut down the drive:	21
Reversing	21
Starting and Stopping Methods	21
Line starting and stopping	22
Decelerating to minimum speed	22
Decelerate to minimum speed using INHIBIT terminals	23
Dynamic braking	24
<b>Calibration</b>	<b>26</b>
Calibration procedure	28
MINIMUM SPEED (MIN SPD)	28
MAXIMUM SPEED (MAX SPD)	29
REGULATION (IR COMP)	29
TORQUE LIMIT (TORQUE)	30

---

<b>Application Notes</b>	<b>32</b>
Reversing with dynamic braking	.32
Reversing with a DLC600	.33
Independent Adjustable Speeds	.34
Adjustable speeds using potentiometers in series	.35
Multiple fixed speeds	.36
RUN/JOG switch	.37
RUN/JOG option #1	.37
RUN/JOG option #2	.38
Leader-follower application	.39
Single speed potentiometer control of multiple drives	.40
<b>Troubleshooting</b>	<b>41</b>
Before troubleshooting	.41
Replacement Parts	.45
<b>Unconditional Warranty</b>	<b>inside back cover</b>

---

# Illustrations

Figure 1.	MM31002A Dimensions	.2
Figure 2.	MM32002A Dimensions	.3
Figure 3.	MM31610A Dimensions	.4
Figure 4.	223-0159 Heat Sink Dimensions	.5
Figure 5.	Speed Adjust Potentiometer Installation	.9
Figure 6.	Power, Fuse and Motor Connections for MM31002A and MM32002A Series Drives	.14
Figure 7.	Voltage Follower Connection for MM31002A and MM32002A Series Drives	.15
Figure 8.	Power, Fuse and Motor Connections for MM31600A Series Drives	.18
Figure 9.	Voltage Follower Connection for MM31600A Series Drives	.19
Figure 10.	Run/Decelerate to Minimum Speed Switch	.22
Figure 11.	Run/Decelerate to Minimum Speed Switch	.23
Figure 12.	Dynamic Brake Connection	.25
Figure 13.	Calibration Trimpot Layout	.27
Figure 14.	Typical IR COMP and TORQUE Settings	.31
Figure 15.	Reversing Circuit Connection	.32
Figure 16.	Reversing with a DLC600	.33
Figure 17.	Independent Adjustable Speeds	.34
Figure 18.	Adjustable Fixed Speeds Using Potentiometers in Series	.35
Figure 19.	Multiple Fixed Speeds	.36
Figure 20.	RUN/JOG Switch (first wiring option)	.37
Figure 21.	RUN/JOG Switch (second wiring option)	.38
Figure 22.	Leader-Follower Application	.39
Figure 23.	Single Speed Potentiometer Control of Multiple Drives	.40

---

# Tables

Table 1.	Field Output Connections	10
Table 2.	Recommended Dynamic Brake Resistor Sizes	24
Table 3.	Replacement Parts	45

# Notes

# Specifications

	<b>MM31002A</b>	<b>MM32002A</b>	<b>MM31610A</b>
<b>Line voltage</b>	115 VAC	230 VAC	115 VAC
<b>Horsepower</b>	1/8-1/2*	1/4-1*	1/20 - 1/4
<b>Armature output</b>	0-90 VDC	0-180 VDC	0-90 VDC
<b>Max arm curr.</b>	5 ADC**	5 ADC**	2.5 ADC
<b>Field output</b>	50/100 VDC	100/200 VDC	50 VDC

\*Max HP = 1 and max armature current = 10 ADC if mounted on 223-0159 heat sink.

\*\*Max HP = 2 and max armature current = 10 ADC if mounted on 223-0159 heat sink.

AC Line Voltage Tolerances	-5% +10%, 50/60 Hz, single phase
Maximum Output Field Current	1 ADC
Form Factor	1.37 at base speed
Accel. Time Range	0.5 – 11 seconds
Decel. Time Range	coast to a stop – 13 seconds
Analog Input Voltage Range (signal must be isolated; S1 to S2)	0 – 5 VDC
Input Impedance (S1 to S2)	100K ohms
Load Regulation	1% base speed or better
Vibration	0.5G max (0 – 50 Hz) 0.1G max (>50 Hz)
Ambient Temp. Range	10°C – 55°C

# Dimensions

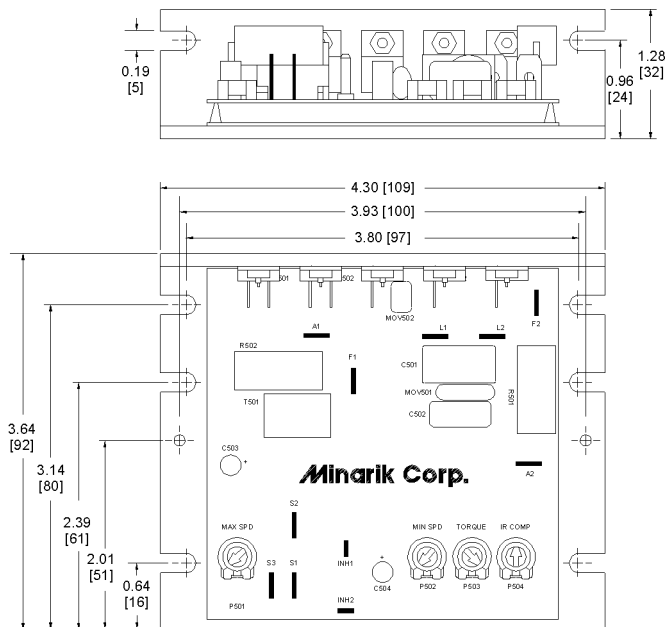

ALL DIMENSIONS IN INCHES [MILLIMETERS]

**Figure 1. MM31002A Dimensions**

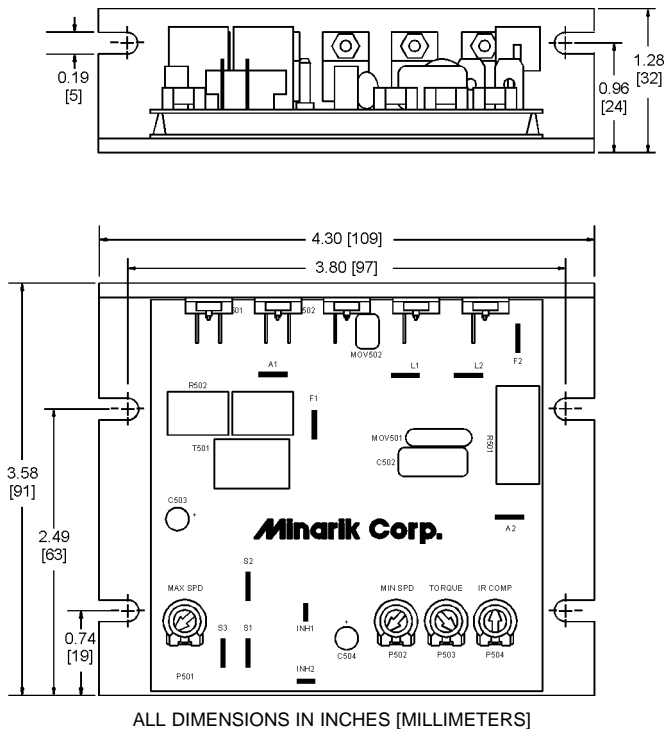
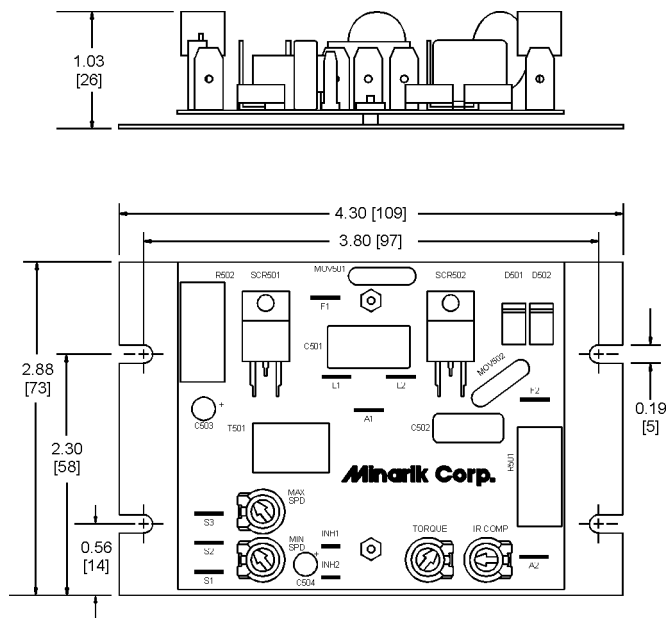
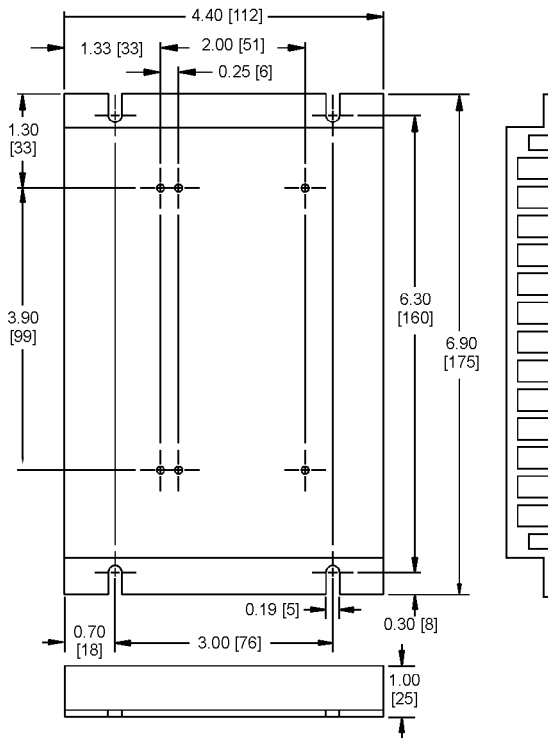

Figure 2. MM32002A Dimensions



ALL DIMENSIONS IN INCHES [MILLIMETERS]

**Figure 3. MM31610A Dimensions**



ALL DIMENSIONS IN INCHES [MILLIMETERS]

**Figure 4. 223-0159 Heat Sink Dimensions**

---

# Installation

## Mounting



### Warning

**Do not install, rewire, or remove this control with power applied.** Doing so may cause fire or serious injury. Make sure you have read and understood the Safety Warnings before attempting installation.

The chassis must be earth grounded. Use a star washer beneath the head of at least one of the mounting screws to penetrate the anodized chassis surface and to reach bare metal.

- Drive components are sensitive to electrostatic fields. Avoid direct contact with the circuit board. Hold drive by the chassis only.
- Protect the drive from dirt, moisture, and accidental contact. Provide sufficient room for access to the terminal block and calibration trimpots.
- Mount the drive away from heat sources. Operate the drive within the specified ambient operating temperature range.
- Prevent loose connections by avoiding excessive vibration of the drive.

## Wiring



### Warning



Do not install, remove, or rewire this equipment with power applied. Failure to heed this warning may result in fire, explosion, or serious injury.

Circuit potentials are at 115 or 230 VAC above ground. To prevent the risk of injury or fatality, avoid direct contact with the printed circuit board or with circuit elements.

Do not disconnect any of the motor leads from the drive unless power is removed or the drive is disabled. Opening any one motor lead may destroy the drive.

Use 18–22 AWG wire for speed adjust potentiometer wiring.  
Use 14–16 AWG wire for AC line (L1, L2), field (F1, F2) and motor (A1 and A2) wiring.

## Shielding guidelines



### Warning

Under no circumstances should power and logic leads be bundled together. Induced voltage can cause unpredictable behavior in any electronic device, including motor controls.

As a general rule, Minarik recommends shielding of all conductors.

If it is not practical to shield power conductors, Minarik recommends shielding all logic-level leads. If shielding logic leads is not practical, the user should twist all logic leads with themselves to minimize induced noise.

It may be necessary to earth ground the shielded cable. If noise is produced by devices other than the drive, ground the shield at the drive end. If noise is generated by a device on the drive, ground the shield at the end away from the drive. Do not ground both ends of the shield.

If the drive continues to pick up noise after grounding the shield, it may be necessary to add AC line filtering devices, or to mount the drive in a less noisy environment.

## Speed adjust potentiometer connections



### Warning

Be sure that the potentiometer tabs do not make contact with the potentiometer enclosure. Grounding the input will cause damage to the drive.

Install the circular insulating disk between the mounting panel and the 10K ohm speed adjust potentiometer (see Figure 5). Mount the speed adjust potentiometer through a 0.38-inch (10 mm) hole with the hardware provided. Twist the speed adjust potentiometer wires to avoid picking up unwanted electrical noise.

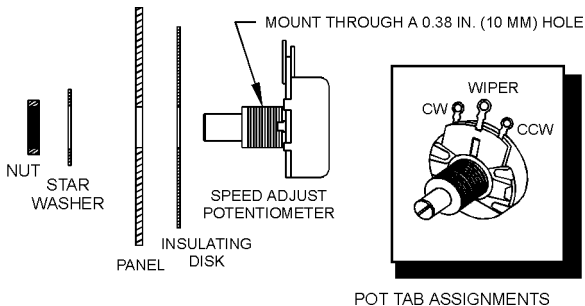

**Figure 5. Speed Adjust Potentiometer Installation**

## Field output



### Warning

The field output is for shunt wound motors only. Do not make any connections to F1 and F2 when using a permanent magnet motor.

Use 18 AWG wire to connect the field output to a shunt wound motor. See Table 1 for field output connections.

**Table 1. Field Output Connections**

Line Voltage (VAC)	Approximate Field Voltage (VDC)	Connect Motor Field To
115	50	F1 and L1
115	100	F1 and F2
230	100	F1 and L1
230	200	F1 and F2

## Heat sinking

All MM31600A series drives contain sufficient heat sinking in their basic configurations. MM31002A and MM32002A series drives require heat sink kit 223-0159 when the continuous armature current is above 5 ADC. Refer to *Specifications* (page 1) for operating limits when mounted on a heat sink.

## Line fusing

Minarik drives require an external fuse for protection. Use fast acting fuses rated for 250 VAC or higher, and 150% of maximum motor armature current. Minarik Corporation offers two fuse kits: part number 050-0066 (1-5A Fuse Kit) and 050-0071 (5-15A Fuse Kit). See *Replacement Parts* (page 45) for fuse kit contents.

## Connections



### Warning

Do not connect this equipment with power applied. Failure to heed this directive may result in fire or serious injury.

Do not apply 230 VAC line voltage to MM31002A or MM31600A series drives. This will result in severe damage to the drive, possible fire and serious injury.

Minarik strongly recommends the installation of a master power switch in the voltage input line. The switch contacts should be rated at a minimum of 200% of motor nameplate current and 250 volts.

### **MM31002A and MM32002A series drives**

Connect the power input leads, external line fuse(s) and DC motor to the drive's printed circuit board (PCB) as shown in Figure 6 (page 14).

## Motor connections

Minarik drives supply motor voltage from A1 and A2 terminals. It is assumed throughout this manual that, when A1 is positive with respect to A2, the motor will rotate clockwise (CW) while looking at the output shaft protruding from the front of the motor. If this is opposite of the desired rotation, simply reverse the wiring of A1 and A2 with each other.

Connect a DC motor to PCB terminals A1 and A2 as shown in Figure 6. **Ensure that the motor voltage rating is consistent with the drive's output voltage.**

## Line fuse

Wire an external, 15-Amp line fuse between the stop switch (if installed) and the L1 terminal. An additional line fuse should be installed on L2 if the input voltage is 230 VAC. The line fuse(s) should be rated at 250 volts.

## Power connections



### Warning

Do not apply 230 VAC line voltage to MM31002A or MM31600A series drives. This will result in severe damage to the drive, possible fire and serious injury.

Connect the AC line power leads to terminals L1 and L2, or to a double-throw, single-pole master power switch (recommended).

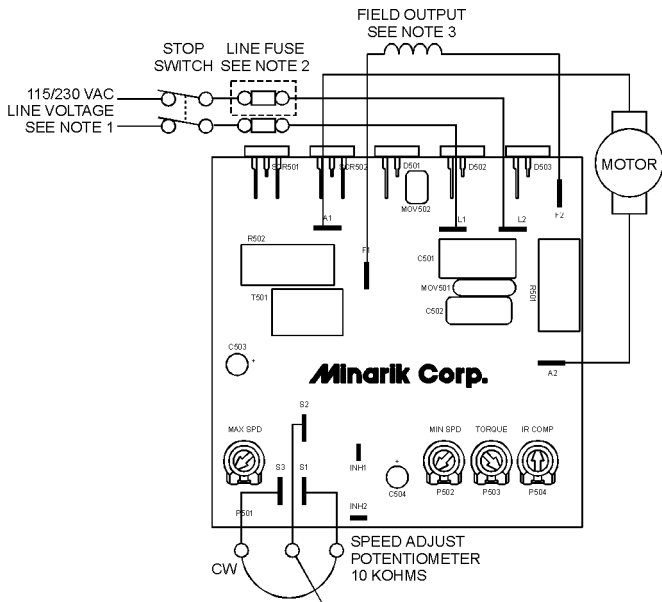
**NOTES:**

1. DO NOT CONNECT 230 VAC LINE VOLTAGE TO MM31002A SERIES DRIVES.
2. DO NOT ADD A LINE FUSE TO L2 UNLESS LINE VOLTAGE IS 230 VAC.
3. DO NOT CONNECT FIELD COILS IF USING A PERMANENT-MAGNET MOTOR. REFER TO TABLE 1 (PAGE 10) FOR ALTERNATE FIELD CONNECTIONS.

**Figure 6. Power, Fuse and Motor Connections for MM31002A and MM32002A Series Drives**



## MM31600A series drives

Connect the power input leads, external line fuse and DC motor to the drive's printed circuit board (PCB) as shown in Figure 8 (page 18).

### Motor connections

Minarik drives supply motor voltage from A1 and A2 terminals. It is assumed throughout this manual that, when A1 is positive with respect to A2, the motor will rotate clockwise (CW) while looking at the output shaft protruding from the front of the motor. If this is opposite of the desired rotation, simply reverse the wiring of A1 and A2 with each other.

Connect a DC motor to PCB terminals A1 and A2 as shown in Figure 8. **Ensure that the motor voltage rating is consistent with the drive's output voltage.**

### Line fuse

Wire an external line fuse between the stop switch (if installed) and the L1 terminal. The line fuse should be rated at 250 volts and 150 - 200% of maximum motor nameplate current.

---

## Power connections



### Warning

Do not apply 230 VAC line voltage to MM31002A or MM31600A series drives. This will result in severe damage to the drive, possible fire and serious injury.

Connect the AC line power leads to terminals L1 and L2, or to a double-throw, single-pole master power switch (recommended).

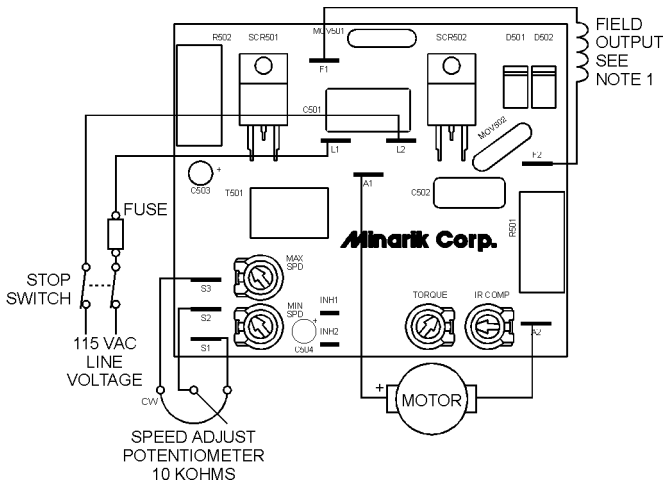
**NOTES:**

1. DO NOT CONNECT FIELD COILS IF USING A PERMANENT-MAGNET MOTOR. REFER TO TABLE 1 (PAGE 10) FOR ALTERNATE FIELD CONNECTIONS.

**Figure 8. Power, Fuse and Motor Connections for MM31600A Series Drives**

## Voltage follower connection

Instead of using a speed adjust potentiometer, the drive may be wired to follow a 0-5 VDC analog input voltage signal that is isolated from earth ground (Figure 9). Connect the signal reference (+) to S2. Connect the signal common (-) to INH2. Make no connection to S1 or S3.

A potentiometer can be used to scale the analog input voltage. An interface device, such as Minarik model PCM4, may be used to scale and isolate an analog input voltage.

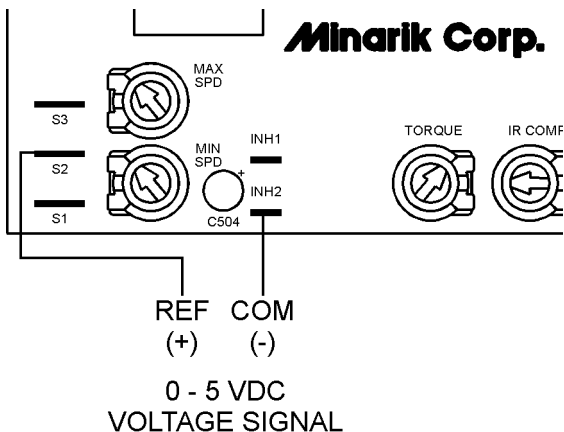

**Figure 9. Voltage Follower Connection for MM31600A Series Drives**

# Operation



## Warning

Dangerous voltages exist on the drive when it is powered. BE ALERT. High voltages can cause serious or fatal injury.

## Before applying power

- Verify that no conductive material is present on the printed circuit board.
- Verify that the AC supply is properly balanced.

## Drive startup and shutdown

1. Set the reference signal or speed adjust potentiometer to minimum speed.
2. Apply AC line voltage.
3. Slowly turn the speed adjust potentiometer or increase the reference voltage until the desired speed is reached.

## To shut down the drive:

To decelerate the motor from set speed to a stop, set the speed adjust potentiometer to zero speed. To coast the motor from set speed to a stop, short INHIBIT terminals INH1 and INH2.

## Reversing

Refer to *Application Notes* (page 32) for reversing options, or contact your Minarik sales representative.

## Starting and Stopping Methods



### Warning

For frequent starts and stops, use dynamic braking, inhibit mode, or decelerating to a stop (shorting S2 to S1). Do not use any of these methods for emergency stopping. They may not stop a drive that is malfunctioning. Removing AC line power (both L1 and L2) is the only acceptable method for emergency stopping.

For this reason, Minarik strongly recommends the installation of an emergency stop switch. The switch contacts should be rated at a minimum of 250 volts and 200% of maximum motor current.

## Line starting and stopping

When AC line voltage is applied to the drive, the motor accelerates to the set speed. When AC line voltage is removed, the motor coasts to a stop. Line stopping (removing AC line voltage) is recommended for stopping in emergency situations only. It is not recommended for frequent starting and stopping.

## Decelerating to minimum speed

The switch shown in Figure 10 may be used to decelerate a motor to a minimum speed. Closing the switch between S1 and S2 decelerates the motor from set speed to a minimum speed determined by the MIN SPD trimpot setting. If the MIN SPD trimpot is set full CCW, the motor decelerates to zero speed when the switch between S1 and S2 is closed.

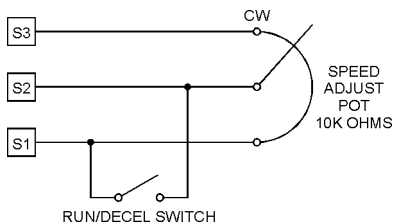

**Figure 10. Run/Decelerate to Minimum Speed Switch**

## Decelerate to minimum speed using INHIBIT terminals

Short the INHIBIT terminals (INH1 and INH2) to coast the motor to minimum speed (Figure 11). Reopen the INHIBIT terminals to accelerate the motor to set speed.

Twist inhibit wires and separate them from other power-carrying wires or sources of electrical noise. Use shielded cable if the inhibit wires are longer than 18 inches (46 cm). If shielded cable is used, ground only one end of the shield to earth ground. Do not ground both ends of the shield.

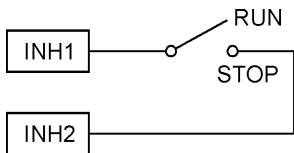
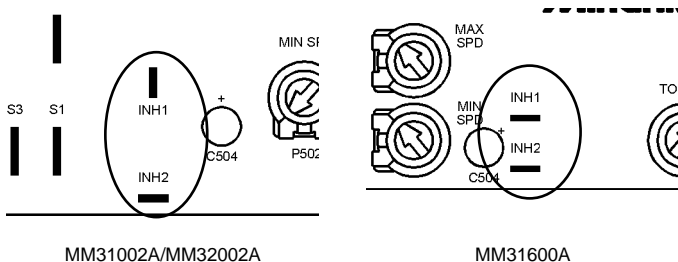

Figure 11. Run/Decelerate to Minimum Speed Switch

## Dynamic braking



### Warning

Wait for the motor to completely stop before switching it back to RUN. This will prevent high armature currents from damaging the motor or drive.

**NOTE:** For motors rated 1/17 horsepower and lower, a brake resistor is not necessary since the armature resistance is high enough to stop the motor without demagnetization. Replace the dynamic brake resistor with 12 gauge wire.

Dynamic braking may be used to rapidly stop a motor (Figure 12). For the RUN/BRAKE switch, use a double-pole, double-throw switch rated for at least the maximum DC armature voltage and maximum braking current.

**Table 2. Recommended Dynamic Brake Resistor Sizes**

Motor Armature Current Rating	Minimum Dynamic Brake Resistor Value	Minimum Dynamic Brake Resistor Wattage
Less than 2 ADC	1 ohm	1W
2–3 ADC	5 ohm	5W
3–5 ADC	10 ohm	10W
5–10 ADC	20 ohm	20W
10–17 ADC	40 ohm	50W

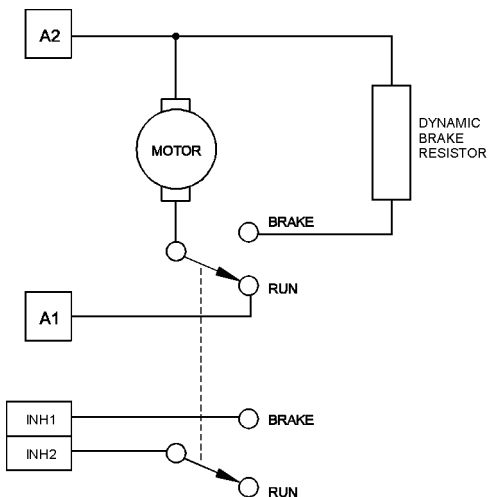

**Figure 12. Dynamic Brake Connection**

# Calibration



## Warning

Dangerous voltages exist on the drive when it is powered. When possible, disconnect the voltage input from the drive before adjusting the trimpots. If the trimpots must be adjusted with power applied, use insulated tools and the appropriate personal protection equipment. **BE ALERT.** High voltages can cause serious or fatal injury.

MM31002A, MM32002A and MM31600A Series drives have four user-adjustable trimpots. Each drive is factory calibrated to its maximum current rating. Readjust the calibration trimpot settings to accommodate lower current-rated motors. See Figure 13 for trimpot location.

All adjustments increase with CW rotation and decrease with CCW rotation. Use a non-metallic screwdriver for calibration. Each trimpot is identified on the printed circuit board.

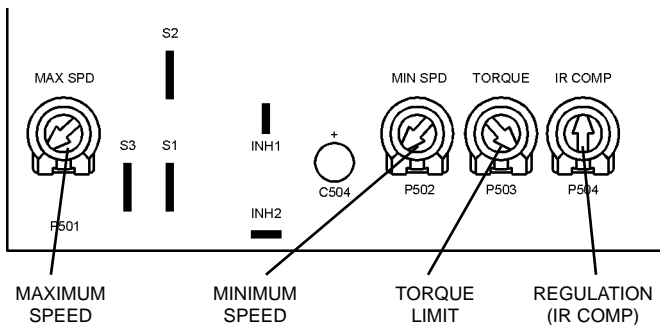

## MM31002A AND MM32002A SERIES DRIVES

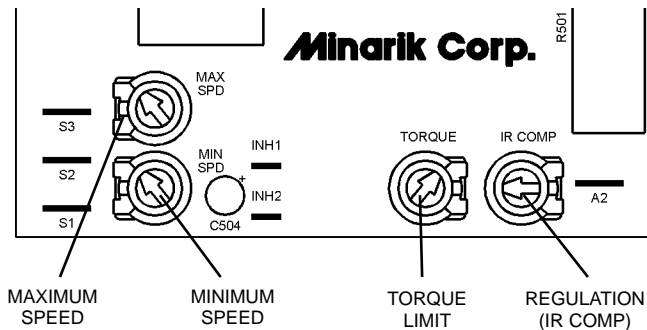

## MM31600A SERIES DRIVES

Figure 13. Calibration Trimpot Layout

## Calibration procedure

Calibrate the drive using the following procedure:

1. Set the MIN SPD and MAX SPD trimpots to zero (full CCW).
2. Set the TORQUE trimpot to maximum (full CW).
3. Set the IR COMP trimpot to midrange (approximate 12 o'clock position).
4. Set the signal input (analog voltage signal or speed adjust potentiometer) to zero.
5. Apply power to the drive.
6. Calibrate the trimpots as follows:

### MINIMUM SPEED (MIN SPD)

The MIN SPD setting determines the motor speed when the speed adjust potentiometer is turned full CCW. It is factory set for minimum rated speed.

To calibrate, set the MIN SPD trimpot full CCW. Set the speed adjust potentiometer or reference signal to minimum. Adjust the MIN SPD trimpot until the desired minimum motor speed is reached.

## **MAXIMUM SPEED (MAX SPD)**

The MAX SPD setting determines the motor speed when the speed adjust potentiometer is turned full CW. It is factory set for maximum rated speed.

To calibrate, set the MAX SPD trimpot full CCW. Set the speed adjust potentiometer or reference voltage to maximum. Adjust the MAX SPD trimpot until the desired maximum motor speed is reached.

## **REGULATION (IR COMP)**

The IR COMP trimpot setting determines the degree to which motor speed is held constant as the motor load changes. It is factory set for optimum motor regulation. See Figure 14 (page 31) for typical IR COMP settings.

To calibrate IR COMP (exact calibration):

1. Turn the IR COMP trimpot full CCW.
2. Set the speed adjust potentiometer until the motor runs at midspeed without load (for example, 900 RPM for an 1800 RPM motor) A hand held tachometer may be used to measure motor speed.
3. Load the motor armature to its full load armature current rating. The motor should slow down.
4. While keeping the load on the motor, rotate the IR COMP trimpot until the motor runs at the speed measured in step 2.

## TORQUE LIMIT (TORQUE)



### Warning

Although TORQUE LIMIT is set to 120% of maximum drive current rating, continuous operation beyond that rating may damage the motor. If you intend to operate beyond the rating, contact your Minarik representative for assistance.

The TORQUE setting determines the maximum torque for accelerating and driving the motor (Figure 14). TORQUE is factory set at 120% of maximum drive current. You must recalibrate the TORQUE setting if using a lower current motor.

1. With no power applied to the drive, connect a DC ammeter in series with the motor armature.
2. Set the CURRENT LIMIT trimpot to full CCW.
3. Carefully lock the motor armature. Ensure that the motor is firmly mounted.
4. Apply line power. The motor should be stopped.
5. Set the speed potentiometer or reference signal to maximum speed. The motor should remain stopped.
6. Slowly rotate the TORQUE trimpot clockwise (CW) until the ammeter reads 120% of maximum motor armature current.
7. Set the speed adjust potentiometer or reference signal to zero speed.
8. Remove power from the drive.
9. Remove the lock from the motor shaft.
10. Remove the ammeter in series with the motor armature.

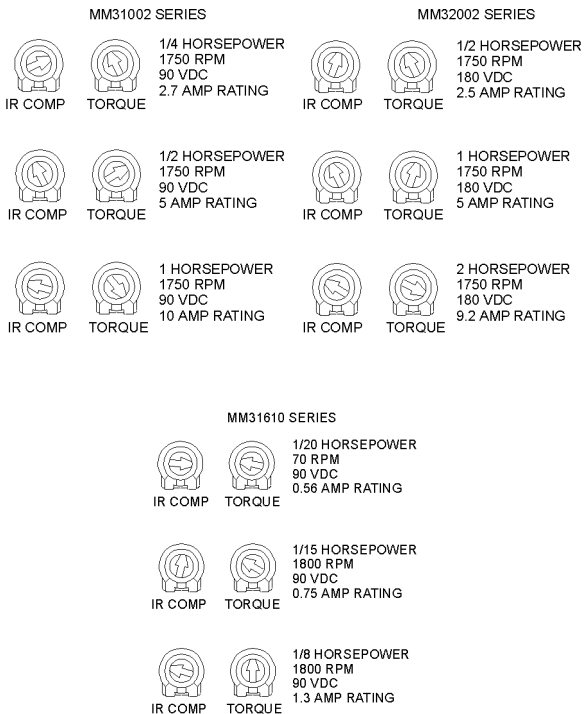

**Figure 14. Typical IR COMP and TORQUE Settings  
(settings may vary by application)**

# Application Notes

## Reversing with dynamic braking

Always use dynamic braking when reversing the motor direction (Figure 15). Use a three-pole, three-position switch rated for at least the maximum DC armature voltage and maximum braking current. Wait for the motor to stop completely before switching it to either the forward or reverse direction. See *Dynamic braking* (page 24) for more information.

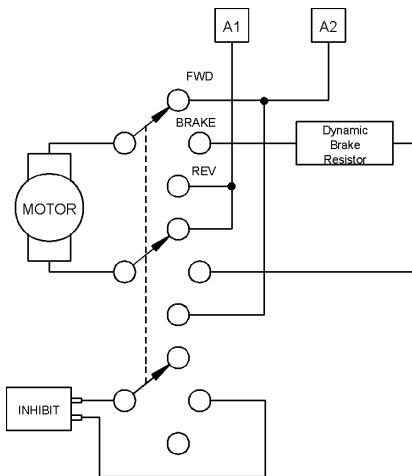
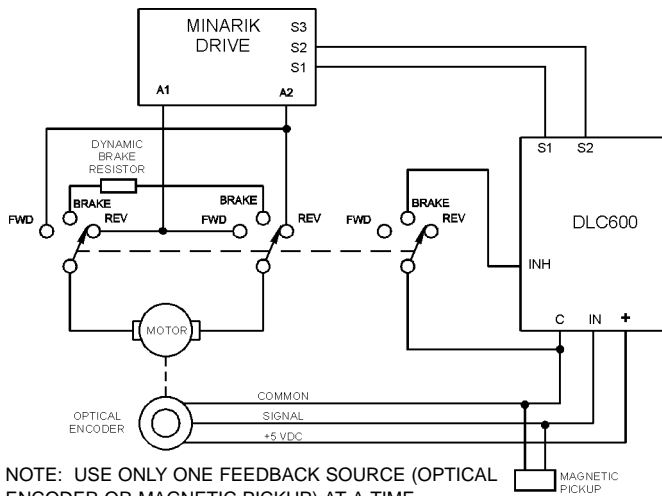

Figure 15. Reversing Circuit Connection

## Reversing with a DLC600

DIGI-LOK controller DLC600 can be used in a reversing application. The controller must be inhibited while braking. Without the inhibit feature, the controller will continue to regulate, causing overshoot when the DIGI-LOK is switched back to the drive.

Figure 16 shows the connection of the reversing circuit to an MM20000 series drive and a DLC600.



**Figure 16. Reversing with a DLC600**

## Independent Adjustable Speeds

Connect two speed adjust potentiometers with a single pole two position switch to select between two independent speeds shown in the forward direction (Figure 17). The parallel resistance of the potentiometers must be equal to 10K ohms. The speed adjust potentiometers can be mounted at two separate operating stations.

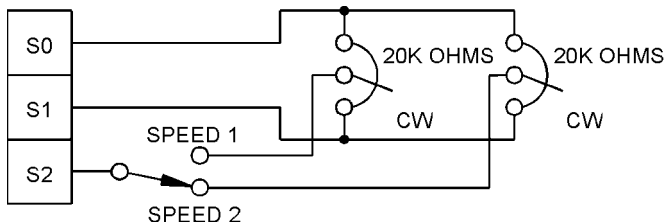

**Figure 17. Independent Adjustable Speeds**

## Adjustable speeds using potentiometers in series

Replace the speed adjust potentiometer with a single-pole, multi-position switch, and two or more potentiometers in series, with a total series resistance of 10K ohms. Figure 18 shows a connection for fixed high and low speed adjust potentiometers.

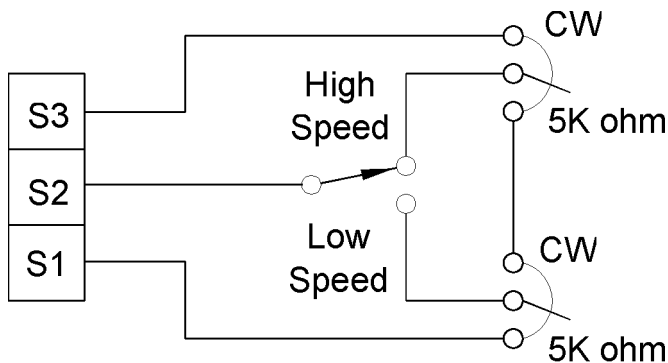

**Figure 18. Adjustable Fixed Speeds  
Using Potentiometers in Series**

## Multiple fixed speeds

Replace the speed adjust potentiometer with series resistors with a total series resistance of 10K ohms (Figure 19). Add a single pole, multi-position switch with the correct number of positions for the desired number of fixed speeds.

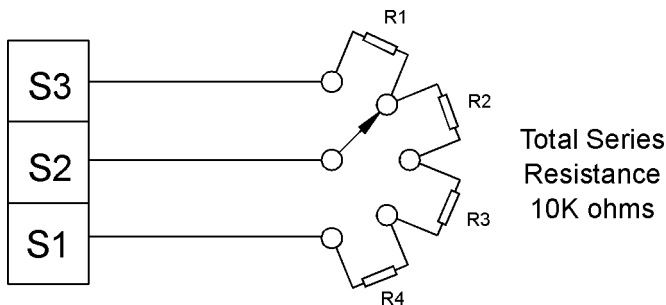

Figure 19. Multiple Fixed Speeds

## RUN/JOG switch

Using a RUN/JOG switch is recommended in applications where quick stopping is not needed and frequent jogging is required. Use a single pole, two position switch for the RUN/JOG switch, and a single pole, normally closed, momentary operated pushbutton for the JOG pushbutton.

### RUN/JOG option #1

In the first wiring option (see Figure 20), connect the RUN/JOG switch and JOG pushbutton to the inhibit plug as shown below. The motor coasts to a stop when the RUN/JOG switch is set to JOG. Press the JOG pushbutton to jog the motor. Return the RUN/JOG switch to RUN for normal operation.

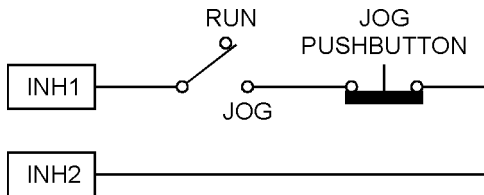
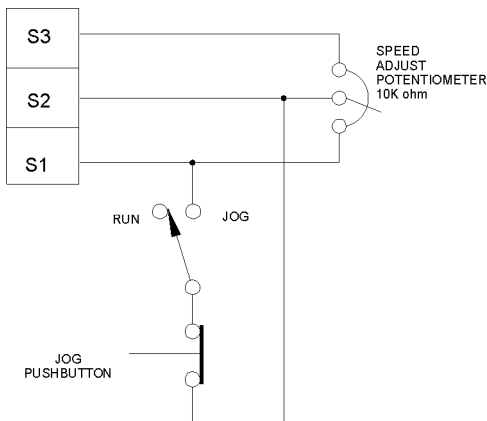

Figure 20. RUN/JOG Switch (first wiring option)

## RUN/JOG option #2

In the second wiring option, connect the RUN/JOG switch and the JOG pushbutton as shown in Figure 21. When the RUN/JOG switch is set to JOG, the motor decelerates to minimum speed (minimum speed is determined by the MIN SPD trimpot setting). Press the JOG pushbutton to jog the motor. Return the RUN/JOG switch to RUN for normal operation.



**Figure 21. RUN/JOG Switch (second wiring option)**

## Leader-follower application

In this application, use a PCM4 to monitor the speed of the leader motor (Figure 22). The PCM4 isolates the leader motor from the follower drive, and outputs a voltage proportional to the leader motor armature voltage. The follower drive uses this voltage reference to set the speed of the follower motor. An optional ratio potentiometer may be used to scale the PCM4 output voltage.

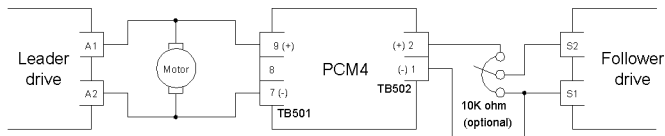

**Figure 22. Leader-Follower Application**

## Single speed potentiometer control of multiple drives

Multiple drives can be controlled with a single speed adjust potentiometer using a PCM4 at the input of each drive to provide isolation (Figure 23). Optional ratio potentiometers can be used to scale the PCM4 output voltage, allowing independent control of each drive.

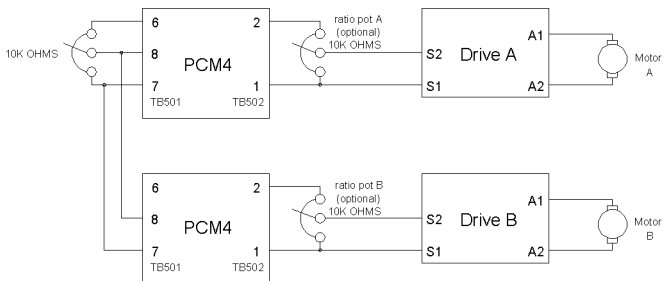

**Figure 23. Single Speed Potentiometer Control of Multiple Drives**

---

# Troubleshooting



## Warning

Dangerous voltages exist on the drive when it is powered. When possible, disconnect the drive while troubleshooting. High voltages can cause serious or fatal injury.

## Before troubleshooting

Perform the following steps before starting any procedure in this section:

- Disconnect AC line voltage from the drive.
- Check the drive closely for damaged components.
- Check that no conductive or other foreign material has become lodged on the printed circuit board.
- Verify that every connection is correct and in good condition.
- Verify that there are no short circuits or grounded connections.
- Check that the drive's rated armature outputs are consistent with the motor ratings.

For additional assistance, contact your local Minarik distributor, or the factory direct:

(800) MINARIK (646-2745) (phone) or (800) 394-6334 (fax).

<b>Symptom</b>	<b>Possible Causes</b>	<b>Suggested Solutions</b>
Line fuse blows	<ol style="list-style-type: none"> <li>1. Line fuses are the wrong size.</li> <li>2. Motor cable or armature is shorted to ground.</li> <li>3. Nuisance tripping caused by a combination of ambient conditions and high-current spikes.</li> <li>4. Field circuit is shorted.</li> </ol>	<ol style="list-style-type: none"> <li>1. Check that line fuses are the proper size.</li> <li>2. Check motor cable and armature for shorts.</li> <li>3. Add a blower to cool the drive components; decrease TORQUE settings, <b>or</b> resize motor and drive for actual load demand, <b>or</b> check for incorrectly aligned mechanical components or “jams”. See page 30 for information on adjusting the TORQUE trimpot.</li> <li>4. Send in drive to Minarik repair department.</li> </ol>
Line fuse does not blow, but the motor does not run	<ol style="list-style-type: none"> <li>1. Speed adjust potentiometer or reference signal is set to zero speed.</li> <li>2. Speed adjust potentiometer or reference signal connections are open.</li> </ol>	<ol style="list-style-type: none"> <li>1. Increase speed adjust potentiometer or reference signal setting.</li> <li>2. Check that the speed adjust potentiometer or reference signal connections are not open.</li> </ol>

<b>Symptom</b>	<b>Possible Causes</b>	<b>Suggested Solutions</b>
Line fuse does not blow, but the motor does not run (cont.)	3. Drive is overloaded.  4. Drive is not receiving AC line voltage.  5. Motor is not connected.	3. Verify that the motor is not jammed. Increase TORQUE setting (page 30)  4. Apply AC line voltage to L1 and L2.  5. Connect motor to A1 and A2.
Motor runs too fast at maximum speed setting	1. MIN SPD and MAX SPD settings are too high.  2. Field connections are loose (shunt-wound motors only)	1. Recalibrate MIN SPD (page 28) and MAX SPD (page 29).  2. Check field connections
Motor runs too slow or too fast	MIN SPD and MAX SPD are not calibrated.	1. Recalibrate MIN SPD (page 28) and MAX SPD (page 29).
Motor will not reach the desired speed.	1. MAX SPD setting is too low.  2. IR COMP setting is too low.	1. Increase MAX SPD setting (page 29).  2. Increase IR COMP setting (page 29).

<b>Symptom</b>	<b>Possible Causes</b>	<b>Suggested Solutions</b>
Motor will not reach the desired speed (cont.)	3. Motor is overloaded.	3. Check motor load. Resize the motor and drive if necessary.
Motor pulsates or surges under load	1. IR COMP is set too high.  2. Control is in current limit mode.	1. Adjust the IR COMP setting slightly CCW until the motor speed stabilizes (page 29).  2. Check that motor is of sufficient horsepower and amperage.

## Replacement Parts

Replacement parts are available from Minarik Corporation and its distributors for this drive series.

**Table 3. Replacement Parts**

<b>Model No.</b>	<b>Symbol</b>	<b>Description</b>	<b>Minarik® P/N</b>
<b>MM31002A</b>	C503	22 uF, 25 VDC Capacitor	011-0046
	D501-503	D8020L Diode	071-0039
	SCR501-502	S8020L High-power SCR	072-0043
	R501	0.01 Ohm, 5W Resistor	032-0065
	R502	5 Kohm, 5W Resistor	032-0028
	T501	Pulse Transformer	230-0004
		Chassis	222-0130
	10K Ohm Pot Kit	202-0058	
<b>MM32002A</b>	Same as MM31002A except:		
	R502-503	5 Kohm, 5W Resistor	032-0088
		Chassis	222-0079
<b>MM31610A</b>	Same as MM31002A except:		
	D501-502	1N5406 Diode	071-0007
	R501	0.05 Ohm, 3W Resistor	032-0073
	T501	Pulse Transformer	230-0004
		Chassis	221-0059

**FUSE KIT CONTENTS****1 -5A FUSE KIT (050-0066)**

2 EA 1 AMP 3AG FAST-ACTING FUSE	050-0042
2 EA 1-1/2 AMP 3AG FAST-ACTING	050-0026
2 EA 3 AMP 3AG FAST-ACTING FUSE	050-0021
2 EA 5 AMP 3AG FAST-ACTING FUSE	050-0022

**5 - 15A FUSE KIT (050-0071)**

2 EA 5 AMP 3AG FAST-ACTING FUSE	050-0022
2 EA 8 AMP 3AG FAST-ACTING FUSE	050-0059
2 EA 10 AMP 3AB NORMAL-BLO FUSE	050-0024
2 EA 15 AMP 3AB NORMAL-BLO FUSE	050-0018

**202-0058 POTENTIOMETER KIT CONTENTS**

1 EA 10K OHM $\pm 10$ % POTENTIOMETER, 2W	120-0047
1 EA 3/8-32 X 1/2 NUT	151-0007
1 EA 3/8IN INT TOOTH LOCK WASHER	152-0007
1 EA POT INSULATING WASHER	156-0022
9 EA NON-INSULATED FEMALE TAB 1/4IN	163-0028
2 EA QUICK DISCONNECT 18-22 AWG	163-0072

## **Unconditional Warranty**

### **A. Warranty**

Minarik Corporation (referred to as "the Corporation") warrants that its products will be free from defects in workmanship and material for twelve (12) months or 3,000 hours, whichever comes first, from date of manufacture thereof. Within this warranty period, the Corporation will repair or replace, at its sole discretion, such products that are returned to Minarik Corporation, 901 East Thompson Avenue, Glendale, CA 91201-2011 USA.

This warranty applies only to standard catalog products, and does not apply to specials. Any returns for special controls will be evaluated on a case-by-case basis. The Corporation is not responsible for removal, installation, or any other incidental expenses incurred in shipping the product to and from the repair point.

### **B. Disclaimer**

The provisions of Paragraph A are the Corporation's sole obligation and exclude all other warranties of merchantability for use, express or implied. The Corporation further disclaims any responsibility whatsoever to the customer or to any other person for injury to the person or damage or loss of property of value caused by any product that has been subject to misuse, negligence, or accident, or misapplied or modified by unauthorized persons or improperly installed.

### **C. Limitations of Liability**

In the event of any claim for breach of any of the Corporation's obligations, whether express or implied, and particularly of any other claim or breach of warranty contained in Paragraph A, or of any other warranties, express or implied, or claim of liability that might, despite Paragraph B, be decided against the Corporation by lawful authority, the Corporation shall under no circumstances be liable for any consequential damages, losses, or expense arising in connection with the use of, or inability to use, the Corporation's product for any purpose whatsoever.

An adjustment made under warranty does not void the warranty, nor does it imply an extension of the original 12-month warranty period. Products serviced and/or parts replaced on a no-charge basis during the warranty period carry the unexpired portion of the original warranty only.

If for any reason any of the foregoing provisions shall be ineffective, the Corporation's liability for damages arising out of its manufacture or sale of equipment, or use thereof, whether such liability is based on warranty, contract, negligence, strict liability in tort, or otherwise, shall not in any event exceed the full purchase price of such equipment.

Any action against the Corporation based upon any liability or obligation arising hereunder or under any law applicable to the sale of equipment or the use thereof, must be commenced within one year after the cause of such action arises.



901 East Thompson Avenue  
Glendale, California 91201-2011

Tel: (800) MINARIK (646-2745)

Fax: (800) 394-6334

[www.minarikcorp.com](http://www.minarikcorp.com)

Document Number 250-0101, Revision 2

Printed in the U.S.A – 6/01

\$12.00 North America, \$13.00 Outside North America