

USER'S MANUAL RG SERIES

Models:

**RG100UC
RG200UC**

Copyright © 2000 by
Minarik Corporation

All rights reserved. No part of this manual may be reproduced or transmitted in any form without written permission from Minarik Corporation. The information and technical data in this manual are subject to change without notice. Minarik Corporation and its Divisions make no warranty of any kind with respect to this material, including, but not limited to, the implied warranties of its merchantability and fitness for a given purpose. Minarik Corporation and its Divisions assume no responsibility for any errors that may appear in this manual and make no commitment to update or to keep current the information in this manual.

Printed in the United States of America.

Safety Warnings



- This symbol  denotes an important safety tip or warning. **Please read these instructions carefully** before performing any of the procedures contained in this manual.
- **DO NOT INSTALL, REMOVE, OR REWIRE THIS EQUIPMENT WITH POWER APPLIED.** Have a qualified electrical technician install, adjust and service this equipment. Follow the National Electrical Code and all other applicable electrical and safety codes, including the provisions of the Occupational Safety and Health Act (OSHA), when installing equipment.
- Reduce the chance of an electrical fire, shock, or explosion by proper grounding, over-current protection, thermal protection, and enclosure. Follow sound maintenance procedures.



It is possible for a drive to run at full speed as a result of a component failure. Minarik strongly recommends the installation of a master switch in the main power input to stop the drive in an emergency.

Circuit potentials are at 115 VAC or 230 VAC above earth ground. Avoid direct contact with the printed circuit board or with circuit elements to prevent the risk of serious injury or fatality. Use a non-metallic screwdriver for adjusting the calibration trimpots. Use approved personal protective equipment and insulated tools if working on this drive with power applied.

Contents

Safety Warnings	i
Specifications	1
Dimensions	2
Installation	3
Mounting	3
Wiring	4
Shielding guidelines	5
Heat sinking	6
Speed adjust potentiometer installation	6
Connections	8
Power, fuse and motor connections	8
Optional Speed Adjustment Potentiometer Connections	12
Operation	17
Before Applying Power	17
Drive startup and shutdown	18
Tachogenerator Feedback	19
Calculating the Feedback Resistor Value	19
Line Starting and Line Stopping	22
Calibration	23
FWD TQ	25
REV TQ	26
IR COMP	27
FWD ACC	28

REV ACC	28
MAX SPD	29
DB	29
CURRENT STAB	30
VOLTAGE STAB	30
Troubleshooting	32
Before troubleshooting	32
Replacement Parts	37
Certificate of Compliance	38
End User Responsibilities	38
AC Line Filters	39
Armature Filters	40
Unconditional Warranty	inside back cover

Illustrations

Figure 1. RG100/200UC Dimensions	2
Figure 2. Speed Adjust Potentiometer Installation	7
Figure 3. RG100/200UC Power Connections to Terminal Board TB501	11
Figure 4. Speed Adjust Pot Connections	12
Figure 5. RG100/200UC Signal/Switch Connections to Terminal Board TB502	15
Figure 6. Calibration Trimpot Layout	24
Figure 7. Voltage Stabilization Outputs	30
Figure 8. Recommended FWD TORQUE, REV TORQUE and DB Settings	31

Tables

Table 1. Line Fuse Chart	10
Table 2. Field Output Connections	16
Table 3. Replacement Parts	37
Table 4. AC Line Filters	39
Table 5. Armature Filters	40

Specifications

Model	AC Line Voltage	Maximum Armature Current (Amps DC)	Armature Voltage Range	Horsepower Range
RG100UC	115	10	0 – 90	1/4 – 1
RG200UC	230	10	0 – 180	1/2 – 2
Output Armature Current				10.0 ADC
Form Factor				1.37 at base speed
Acceleration Time				1 second
Deceleration Time				1 second
Load Regulation: With Tachometer Feedback				0.5% of base speed
Without Tachometer Feedback				2% of base speed
RG100UC Output Field Voltage				100 VDC
RG200UC Output Field Voltage				200 VDC
Output Field Current				1.0 ADC
Ambient Temp. Range				10°C–50°C
Vibration				0.5g max (0 – 50 Hz) 0.1g max (above 50 Hz)
Weight				3.1 lb

Dimensions

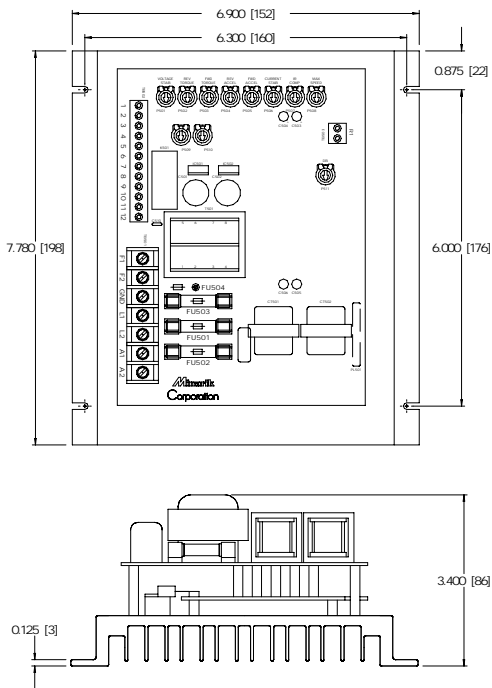

Figure 1. RG100/200UC Dimensions

Installation



Do not install, rewire, or remove this control with input power applied. Doing so may cause fire or serious injury. Make sure you have read and understood the Safety Warnings on pg i before attempting installation.

Mounting

- Drive components are sensitive to electrostatic fields. Avoid direct contact with the circuit board. Hold drive by the chassis only.
- Protect the drive from dirt, moisture, and accidental contact. Provide sufficient room for access to the terminal block and calibration trimpots.
- Mount the drive away from heat sources. Operate the drive within the specified ambient operating temperature range.
- Prevent loose connections by avoiding excessive vibration of the drive.
- Mount drive with its board in either a horizontal or vertical plane. Six 0.19 in. (5 mm) wide slots in the chassis accept #8 pan head screws. Fasten either the large base or the narrow flange of the chassis to the subplate.
- The chassis must be earth grounded. Use a star washer beneath the head of at least one of the mounting screws to penetrate the anodized chassis surface and to reach bare metal.

Wiring



Warning



Do not install, remove, or rewire this equipment with power applied. Failure to heed this warning may result in fire, explosion, or serious injury.

Circuit potentials are at 115 or 230 VAC above ground. To prevent the risk of injury or fatality, avoid direct contact with the printed circuit board or with circuit elements.

Do not disconnect any of the motor leads from the drive unless power is removed or the drive is disabled. Opening any one motor lead may destroy the drive.

- Use 18 AWG wire for speed adjust potentiometer wiring. Use 16 AWG wire for motor field (F1 and F2) wiring and 12 or 14 AWG wire for motor (A1 and A2) and AC line voltage wiring (L1 and L2).

Shielding guidelines



Warning

Under no circumstances should power and logic leads be bundled together. Induced voltage can cause unpredictable behavior in any electronic device, including motor controls.

As a general rule, Minarik recommends shielding of all conductors.

If it is not practical to shield power conductors, Minarik recommends shielding all logic-level leads. If shielding is not practical, the user should twist all logic leads with themselves to minimize induced noise.

It may be necessary to earth ground the shielded cable. If noise is produced by devices other than the drive, ground the shield at the drive end. If noise is generated by a device on the drive, ground the shield at the end away from the drive. Do not ground both ends of the shield.

If the drive continues to pick up noise after grounding the shield, it may be necessary to add AC line filtering devices, or to mount the drive in a less noisy environment.

Logic wires from other input devices, such as motion controllers and PLL velocity controllers, must be separated from power lines in the same manner as the logic I/O on this drive.

Heat sinking

RG100UC and RG200UC drives are mounted on an external heat sink before shipment and therefore have sufficient heat sinking in their basic configurations. No additional heat sinking is necessary.

Speed adjust potentiometer installation



Warning

Be sure that the potentiometer tabs do not make contact with the potentiometer enclosure. Grounding the input will cause damage to the drive.

Speed adjust potentiometers are pre-installed on all cased drives. On chassis drives, install the circular insulating disk between the panel and the 10K Ω speed adjust potentiometer. Mount the speed adjust potentiometer through a 0.38 inch (0.96 cm) hole with the hardware provided (see Figure 2). Twist the speed adjust potentiometer wires to avoid picking up unwanted electrical noise. If potentiometer leads are longer than 18 inches (46 cm), use shielded cable. Do not bundle potentiometer wires with AC power leads.

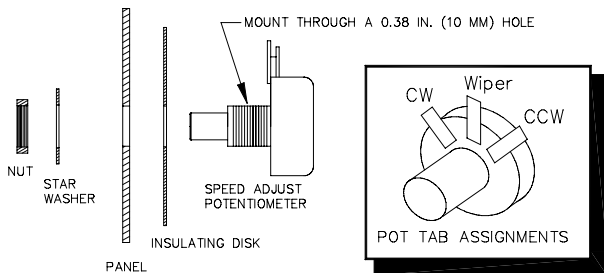

Figure 2. Speed Adjust Potentiometer Installation

Connections



Warning

Do not connect this equipment with power applied.

Failure to heed this directive may result in fire or serious injury. **Minarik strongly recommends the installation of a master power switch in the voltage input line, as shown in Figure 3 (page 11).** The switch contacts should be rated at a minimum of 200% of motor nameplate current and 250 volts.

Power, fuse and motor connections

Connect the power input leads, an external line fuse and a DC motor to the drive as shown in Figure 3 on page 11.

Motor

Connect a DC motor to PCB terminals A1 and A2 as shown in Figure 3 on page 11. **Ensure that the motor voltage rating is consistent with the drive's output voltage.**

Minarik drives supply motor voltage from A1 and A2 terminals. It is assumed throughout this manual that, when A1 is positive with respect to A2, the motor will rotate clockwise (CW) while looking at the output shaft protruding from the front of the motor. If this is opposite of the desired rotation, simply reverse the wiring of A1 and A2 with each other.

Power input



Warning

Minarik strongly recommends the installation of a master power switch in the voltage input line, as shown in Figure 3 (page 11). The switch contacts should be rated at a minimum of 200% of motor nameplate current and 250 volts.

Connect the AC line power leads to terminals L1 and L2, or to a double-throw, single-pole master power switch (recommended).

Line fuse

All drives have line fuses installed (see Replacement Parts section for installed line fuse size). Line fuses are rated for maximum rated horsepower. Fuse L1 when using 115 VAC line voltage. Table 1 (page 10) lists the recommended line fuse sizes.

Table 1. Line Fuse Chart

90 VDC Motor Horsepower	180 VDC Horsepower	Max. DC Armature Current (amps)	AC Line Fuse Size (amps)
1/20	1/10	0.5	3
1/15	1/8	0.8	3
1/8	1/4	1.5	5
1/6	1/3	1.7	5
1/4	1/2	2.6	8
1/3	3/4	3.5	8
1/2	1	5.0	10
3/4	1 1/2	7.6	15
1	2	10	20

Minarik Corporation offers two fuse kits: part number 050-0069 (3-8A Fuse Kit) and 050-0073 (5-20A Fuse Kit). Both fuse kits include a 1/2A pico fuse (part number 050-0074) which protects the transformer and logic.

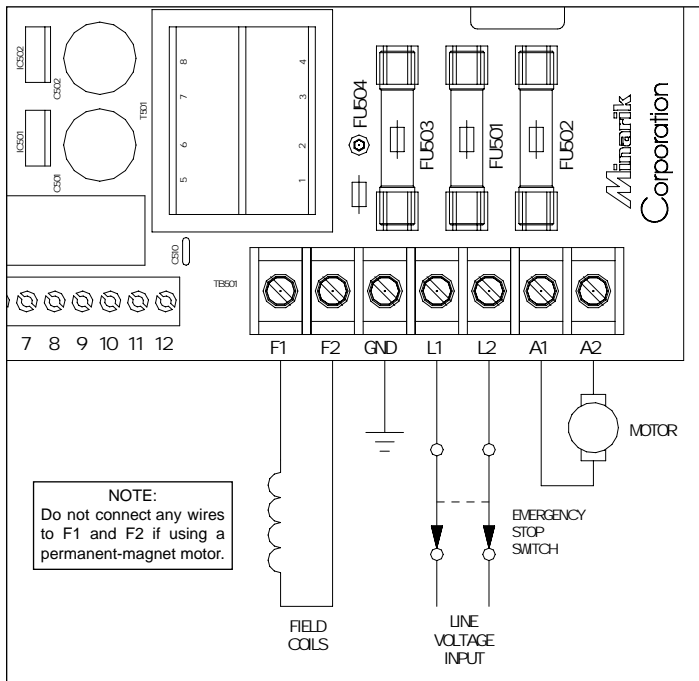

Figure 3. RG100/200UC Power Connections to Terminal Board TB501

Optional Speed Adjustment Potentiometer Connections

For one-way (unidirectional) operation, connect the CCW terminal of the speed pot to terminal 3 of TB502 as shown in Figure 4(a).

For two-way (bidirectional) operation, connect the CCW terminal of the speed pot to terminal 6 of TB502 as shown in Figure 4(b).

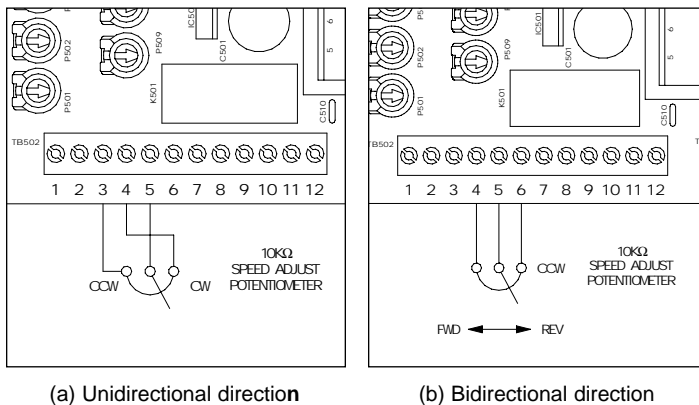

Figure 4. Speed Adjust Pot Connections

Start and Stop Switches

These switches are not supplied with the control. The Start circuit requires a momentary operated normally open switch and the Stop circuit requires a momentary operated normally closed switch. Connect the switches as shown in Figure 5, page 15.

When the Start switch is momentarily actuated, the motor will accelerate to set speed at a rate controlled by the FWD ACC trimpot. When the Stop switch is momentarily actuated, the motor will coast to a stop. To eliminate the Start and Stop switches, connect a jumper between terminals 10 and 12.

Motor Over-Temperature Switch



Warning

If the O/T switch is used, the Start-Stop switches must be connected to terminals 10, 11, and 12 to prevent automatic restart of the motor. See Figure 5 (page 15) for switch connections.

Some motors are available with an internal thermostat which functions as an over-temperature switch. If not used, connect a jumper between terminals 9 and 10 as shown in Figure 5, page 15.

Run/Brake Switch



Warning

The RUN/BRAKE switch acts as an inhibit function and will not unlatch the Start/Stop pushbutton circuit. It may not stop a drive that is malfunctioning. In order to stop the drive in an emergency, Minarik strongly suggests the installation of a stop switch, as shown in Figure 3 (page 11).

The RUN/BRAKE switch is optional. When the switch is in the open position, the motor will run. When the switch is closed, the motor will be regeneratively braked to a stop. See Figure 5 (page 15) for switch connections.

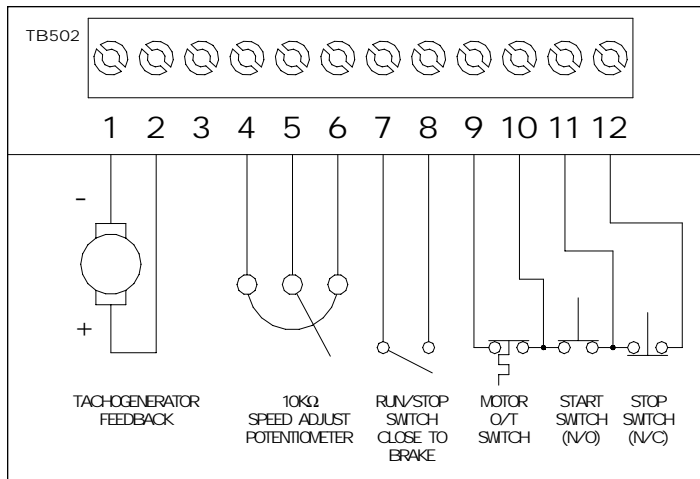

Figure 5. RG100/200UC Signal/Switch Connections to Terminal Board TB502

Field output connections



Warning

The field output is for shunt wound motors only. Do not make any connections to F1 and F2 when using a permanent magnet motor.

Use 18 AWG wire to connect the field output to a shunt wound motor. Table 2 lists the field output connections.

Table 2. Field Output Connections

Line Voltage (VAC)	Approximate Field Voltage (VDC)	Connect Motor Field To
115	50	F1 and L1
115	100	F1 and F2
230	100	F1 and L1
230	200	F1 and F2

Operation



Warning

Dangerous voltages exist on the drive when it is powered. BE ALERT. High voltages can cause serious or fatal injury. For your safety, use personal protective equipment (PPE) when operating this drive.

Before Applying Power

Before operating the control, carefully check that all connections are correct. Check that there are no wire chips or other foreign material on the printed circuit boards. Make sure that the input voltage is the same as listed on the control nameplate.

Drive startup and shutdown



Warning

If the motor does not operate as expected, immediately remove power to the drive. Refer to the Troubleshooting section for assistance.

1. Set the direction select speed adjust pot to its center position. If this pot is wired for unidirectional operation, set the pot to full CCW.
2. If a RUN/BRAKE switch is used, place it in the open (run) position.
3. Apply power to the drive.
4. If Start and Stop pushbuttons are used, press the Start button. (If not used, terminals 10 and 12 must be jumpered.)
5. Slowly turn the direction select speed adjust pot CW or CCW for the desired direction of motor rotation and speed. If the speed adjust pot is wired for unidirectional operation, slowly turn it CW to the desired speed. Verify that the motor starts slowly and increases speed in accordance with the potentiometer setting.
6. To shut down the drive, set the speed adjust pot to its center position (zero speed). (If the drive is wired for unidirectional operation, turn the speed adjust pot full CCW.) Press the STOP pushbutton (if installed).

Tachogenerator Feedback

Tachogenerator feedback is optional. Without tachogenerator feedback, load regulation is approximately 2% of base speed with a speed range of 30 to 1. This is quite acceptable for most applications which do not involve sizable load changes. With tachogenerator feedback, load regulation is better than 0.5% of base speed with a speed range of 50 to 1.

Calculating the Feedback Resistor Value

The following steps are required to convert the control to operate in a closed-loop, tachogenerator mode.

1. The control is factory set for a tachogenerator rated at 50 volts per 1000 RPM, with a maximum motor speed of 1800 RPM. If the tachogenerator output is other than 50 volts per 1000 RPM, or the maximum speed is greater than 1800 RPM, calculate the value of R1 based upon V_{max} , the tachogenerator output voltage at maximum motor speed. Note that V_{max} must be at or greater than 5 volts.

The following equation should be used to properly size the tach feedback resistor, based upon the tachogenerator volts per rpm output and the maximum tachometer speed allowed by the application:

$$R_1 = \frac{[(V/rpm \times RPM_{max}) - 5]}{2.3} \quad \text{Kohms}$$

where R1 is the feedback resistor size in K ohms, V/rpm is the tach output rating and RPMmax is the maximum tach speed allowed.

For example, assume you are using a tachogenerator with an output of 50 volts per 1000 RPM , with a maximum speed of 1800 RPM. Applying the feedback resistor equation, we find:

$$V/rpm = 50V \div 1000 \text{ RPM} = .05$$

$$RPM_{max} = 1800$$

$$R_1 = [(.05 \times 1800) - 5] \div 2.3 = 36.9 \text{ Kohms}$$

Therefore, a 36.9K ohm resistor is required.

Select a standard 1/4 watt resistor of the calculated value and install this resistor on terminal board TB3. If the calculated value is not available, select the next higher standard resistance and, after steps 3 and 4 have been followed, use the MAX SPD ADJ trimpot to set the maximum speed. See page 29 for information on calibrating the MAX SPD ADJ trimpot.

2. Set the IR COMP trim pot fully CCW.
3. Connect the tachogenerator leads to terminals 1 (negative) and 2 (positive) on terminal board TB502. Tachogenerator polarity is that produced with motor running in FORWARD direction.

If any doubt exists concerning the tachogenerator polarity, start the motor very slowly. A miswired tachogenerator will cause the motor to accelerate to full speed. If this occurs, disconnect the control from AC power immediately. Interchange the connections at terminals 1 and 2. Reconnect AC power to the control.

Line Starting and Line Stopping



Warning

Decelerating to minimum speed, regenerative braking, or coasting to a stop is recommended for frequent starts and stops. Do not use any of these methods for emergency stopping. They may not stop a drive that is malfunctioning. Removing AC line power (both L1 and L2) is the only acceptable method for emergency stopping.

For this reason, **Minarik strongly recommends installing an emergency stop switch on both the L1 and L2 inputs** (see *Connections - page 8*).

Connect a jumper between terminals 9 and 12. When AC line power is removed, the motor will coast to a stop. When power is re-applied, the motor will accelerate to the set speed at a rate determined by the ACCEL trimpot setting.

Calibration



Warning

Dangerous voltages exist on the drive when it is powered. When possible, disconnect the voltage input from the drive before adjusting the trimpots. If the trimpots must be adjusted with power applied, use insulated tools and the appropriate personal protection equipment. BE ALERT. High voltages can cause serious or fatal injury.

Each drive is factory calibrated to its maximum current rating. Readjust the calibration trimpot settings to accommodate lower current rated motors. All adjustments increase with CW rotation, and decrease with CCW rotation. Refer to Figure 6 (page 24) for trimpot location.

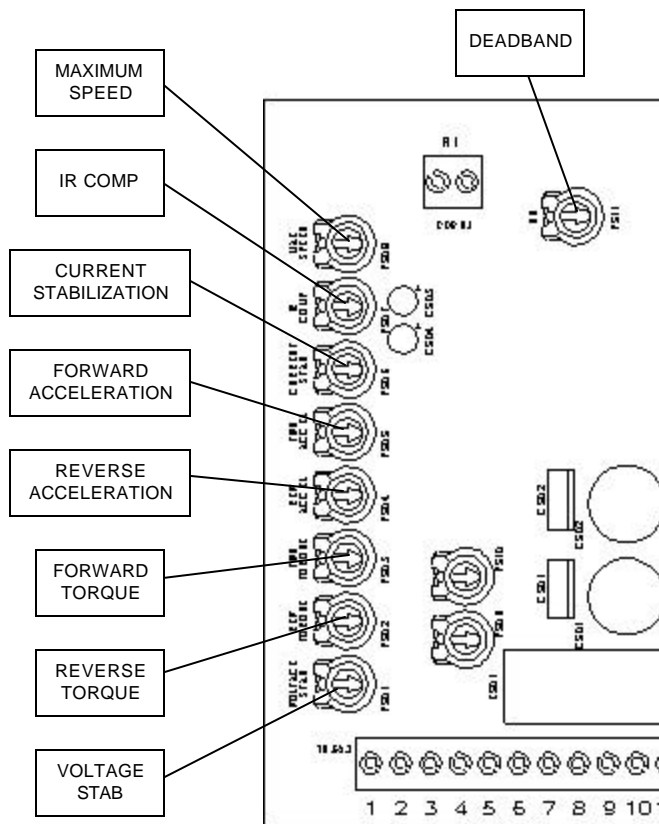

Figure 6. Calibration Trimpot Layout

FWD TQ



Warning

Although FORWARD TORQUE should be set to 120% of drive nameplate current rating, continuous operation beyond this rating may damage the motor. If you intend to operate beyond the rating, contact your Minarik representative for assistance.

The FWD TQ setting determines the maximum torque for accelerating and driving the motor in the forward direction. It also sets the maximum torque for decelerating the motor in the reverse direction. Refer to Figure 8 (page 31) for recommended FWD TQ settings or recalibrate using the following procedure:

1. With the power disconnected from the drive, connect a DC ammeter in series with the armature.
2. Set the FWD TQ trimpot to minimum (full CCW).
3. Set the speed adjust potentiometer to maximum forward speed.
4. Lock the motor shaft. Be sure that the motor is firmly mounted to withstand maximum torque generated by the motor.
5. Apply line power. The motor should be stopped.
6. Slowly adjust the FWD TQ trimpot CW until the armature current is 120% of motor rated armature current.
7. Set the speed adjust potentiometer to minimum.
8. Remove the power from the drive and unlock the motor shaft.
9. Remove the ammeter in series with the motor armature if it is no longer needed and re-apply power to the drive.

REV TQ



Warning

Although REVERSE TORQUE should be set to 120% of drive nameplate current rating, continuous operation beyond this rating may damage the motor. If you intend to operate beyond the rating, contact your Minarik representative for assistance.

The REV TQ setting determines the maximum torque for accelerating and driving the motor in the reverse direction. It also sets the maximum torque for decelerating in the forward direction. Refer to Figure 8 (page 31) for recommended REV TQ settings or recalibrate using the following procedure:

1. With the power disconnected from the drive, connect a DC ammeter in series with the armature.
2. Set the REV TQ trimpot to minimum (full CCW).
3. Set the speed adjust potentiometer to maximum reverse speed.
4. Lock the motor shaft. Be sure that the motor is firmly mounted to withstand maximum torque generated by the motor.
5. Apply line power. The motor should be stopped.
6. Slowly adjust the REV TQ trimpot CW until the armature current is 120% of motor rated armature current.
7. Set the speed adjust potentiometer to minimum.
8. Remove the power from the drive and unlock the motor shaft.
9. Remove the ammeter in series with the motor armature if it is no longer needed and re-apply power to the drive.

IR COMP

The IR COMP trimpot setting determines the degree to which motor speed is held constant as the motor load changes. It is factory set for optimum motor regulation.

Use the following procedure to recalibrate the IR COMP setting:

1. Set the IR COMP trimpot to minimum (full CCW).
2. Rotate the speed adjust potentiometer until the motor runs at midspeed without load (for example, 900 RPM for an 1800 RPM motor). A hand held tachometer may be used to measure motor speed.
3. Load the motor armature to its full load armature current rating. The motor should slow down.
4. While keeping the load on the motor, rotate the IR COMP trimpot until the motor runs at the speed measured in step 2. If the motor oscillates (overcompensation), the IR COMP trimpot may be set too high (CW). Turn the IR COMP trimpot CCW to stabilize the motor.
5. Unload the motor.

FWD ACC

The FWD ACC setting determines the time the motor takes to ramp to either a higher speed in the forward direction or a lower speed in the reverse direction, within the limits of available torque. The FWD ACC setting is factory set for its fastest forward acceleration time.

Turn the FWD ACC trimpot CW to increase the forward acceleration time, and CCW to decrease the forward acceleration time.

REV ACC

The REV ACC setting determines the time the motor takes to ramp to either a higher speed in the reverse direction or a lower speed in the forward direction, within the limits of available torque. The REV ACC setting is factory set for its fastest reverse acceleration time.

Turn the REV ACC trimpot CW to increase the reverse acceleration time, and CCW to decrease the reverse acceleration time.

MAX SPD

The MAX SPD setting determines the maximum motor speed when the speed adjust potentiometer is turned full CW. It is factory set for maximum rated voltage.

To calibrate MAX SPD:

1. Set the MAX trimpot full CCW.
2. Turn the speed adjust potentiometer full CW.
3. Adjust the MAX SPD trimpot until the desired maximum motor speed is reached.

DB

The deadband (DB) trimmer potentiometer determines the time that will elapse between the application of current in one direction before current is applied in the opposite direction.

The deadband trimmer potentiometer affects the resistance that a motor has to changes in shaft position at zero speed. It does this by applying AC voltage to the motor armature.

Deadband is factory calibrated to approximately the 3 o'clock position for 60 Hz AC line operation. Recalibrate the deadband to the 9 o'clock position for 50 Hz AC line operation. See Figure 8 (page 31) for deadband settings.

CURRENT STAB

The effect of this adjustment is most apparent in the DC tachogenerator feedback operating mode. CURRENT STAB is factory set to midrange and should not require adjustment unless the tachogenerator signal has considerable ripple. Then, you should turn this trim pot CW until the motor stabilizes.

VOLTAGE STAB

The effect of this trim pot is most obvious when tachogenerator feedback is used. When optimum adjustment of voltage stabilization is achieved, the speed profile through time should be smooth (Figure A). If the trimpot is set too low, stepping will occur during acceleration and deceleration. It will be especially obvious in the Decel mode (Figure B). If the trimpot is set too high, you may see oscillation at a given set speed (Figure C). VOLTAGE STAB is factory set to midrange.

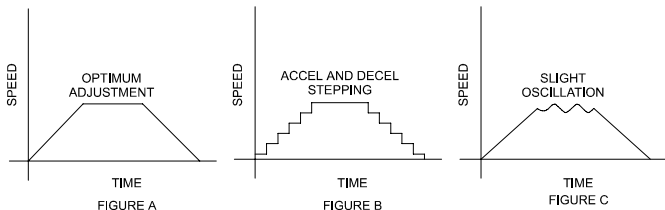
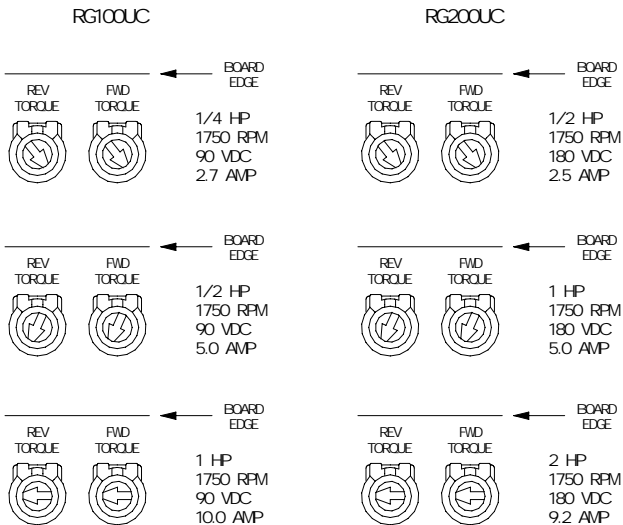

Figure 7. Voltage Stabilization Outputs

FWD TORQUE and REV TORQUE SETTINGS



DEADBAND (DB) SETTINGS

60 Hz Applications 50 Hz Applications

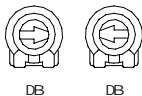

Figure 8. Recommended FWD TORQUE, REV TORQUE and DB Settings

Troubleshooting



Warning

Dangerous voltages exist on the drive when it is powered. When possible, disconnect the drive while troubleshooting. High voltages can cause serious or fatal injury.

Before troubleshooting

Perform the following steps before starting any procedure in this section:

1. Disconnect AC line voltage from the drive.
2. Check the drive closely for damaged components.
3. Check that no conductive or other foreign material has become lodged on the printed circuit board.
4. Verify that every connection is correct and in good condition.
5. Verify that there are no short circuits or grounded connections.
6. Check that the drive's rated armature outputs are consistent with the motor ratings.

For additional assistance, contact your local Minarik® distributor, or the factory direct at:

(800) MINARIK (phone) or (775) 823-9495 (fax).

Problem	Possible Causes	Suggested Solutions
Field fuse blows	<ol style="list-style-type: none"> 1. Field fuse is the wrong size. 2. Motor field is shorted to ground. 3. F1 is shorted to F2. 4. Motor cable is shorted to ground. 5. Motor field leads are reversed with motor armature. 	<ol style="list-style-type: none"> 1. Verify that the fuse is 3 ADC. 2. Check if the motor field is shorted to ground. Replace motor if necessary. 3. Check that F1 and F2 are not shorted together. 4. Check that the motor cable is not shorted to ground. Replace cable if necessary. 5. Wire motor armature to A1 and A2; wire motor field to F1 and F2.
Line fuse blows	<ol style="list-style-type: none"> 1. Line fuses are the wrong size. 2. Motor cable or armature is shorted to ground. 3. Field circuit is open. 4. Nuisance tripping caused by a combination of ambient conditions and high-current spikes (i.e. reversing). 	<ol style="list-style-type: none"> 1. Check that line fuses are 15 A. 2. Check motor cable and armature for shorts. 3. Send in drive to Minarik repair department. 4. Add a blower to cool the drive components; increase FWD TQ and REV TQ settings. See pages 25 and 26.

Problem	Possible Causes	Suggested Solutions
Motor runs too fast at maximum speed setting	<ol style="list-style-type: none"> 1. MAX SPD setting is too high. 2. Motor field connections are loose (shunt wound motors only). 	<ol style="list-style-type: none"> 1. Recalibrate MAX SPD. See page 29. 2. Check motor field connections.
Line fuse does not blow, but the motor does not run	<ol style="list-style-type: none"> 1. Speed adjust pot or voltage input signal set to zero speed. 2. Speed adjust pot or voltage input signal not connected to drive input properly; connections are open. 3. REGEN BRAKE is jumpered. 4. S2 is shorted to S0. 5. Drive is in current limit. 6. Drive is not receiving AC line voltage. 	<ol style="list-style-type: none"> 1. Increase the speed adjust potentiometer, voltage, or current setting. 2. Check connections to input. Verify that connections are not open. 3. Remove jumper from REGEN BRAKE terminal. 4. Remove short. 5. Verify that motor is not jammed. Increase FWD TQ or REV TQ setting if they are set too low. See pages 25 and 26. 6. Apply AC line voltage to L1 and L2.

Problem	Possible Causes	Suggested Solutions
Motor runs too slow or too fast	<ol style="list-style-type: none"> 1. Switches set incorrectly. 2. MAX SPD not calibrated. 3. Motor field not properly connected (shunt wound motors only). 	<ol style="list-style-type: none"> 1. Verify all switch settings. 2. Calibrate MAX SPD. See page 29. 3. Verify motor field connections.
Motor will not reach the desired speed	<ol style="list-style-type: none"> 1. MAX SPD setting is too low. 2. IR COMP setting is too low. 	<ol style="list-style-type: none"> 1. Increase MAX SPD setting. See page 29. 2. Increase the IR COMP setting. See page 27.
Motor pulsates or surges under load	<ol style="list-style-type: none"> 1. IR COMP is set too high. 2. Motor "bouncing" in and out of torque limit. 	<ol style="list-style-type: none"> 1. Adjust the IR COMP setting slightly CCW until the motor speed stabilizes. See page 27. 2. Make sure motor is not undersized for load; adjust FWD TQ and REV TQ trim pots. See pages 25 and 26.
Motor does not reverse	<ol style="list-style-type: none"> 1. Bad speed pot connection to TB502. 2. Reversing circuit not working properly. 	<ol style="list-style-type: none"> 1. Check pot connection to TB502. 2. Check reversing circuit by shorting TB502-5 to TB502-6 with jumper wire.

Problem	Possible Causes	Suggested Solutions
Motor makes a humming or buzzing noise	1. Deadband setting is too high.	1. Turn deadband (DB) trimpot CCW until the noise stops. See page 29.

Replacement Parts

Replacement parts are available from Minarik Corporation and its distributors for this drive series.

Table 3. Replacement Parts

Model No.	Symbol	Description	Minarik P/N
RG100UC	C501 - 502	Capacitor, 470 uF 50V	011-0056
	IC501	LM340T12 Regulator	061-0019
	IC502	LM320T12 Regulator	061-0020
	SCR501 - 508	S8025L SCR	072-0042
	TB501	7-Pin Terminal Block	160-0019
	TB502	12-Pin Terminal Block	160-0086
	T501	115:36 Transformer	230-0071
RG200UC	Same as above, except:		
	T501	115/230 Transformer	230-0072
All models		Fuse Kit, 5 – 20A	050-0073
		Pot Kit, 10K Ohm/5W	202-0003

Certificate of Compliance

Minarik Corporation hereby certifies that its RG100/RG200 Series drives have been approved to bear the “CE” mark provided the conditions of approval have been met by the end user.

The RG100/RG200 Series drives have been tested to the following test specifications:

**EN55011:1991 (emissions), and
EN50082-1:1992 (immunity)**

Compliance allows the RG100/RG200 Series drives to bear the CE mark.

End User Responsibilities

The end user, as described herein, falls into one of two categories:

1. The Consumer will deploy a stand-alone unit as an integral, yet external, portion of the machine being operated.
2. The Original Equipment Manufacturer (OEM) will implement the product as a component of the machine being manufactured.

AC Line Filters

In addition to EMI/RFI safeguards inherent in the RG100/RG200 design, external filtering is required.

Minarik requires the Corcom® AC line filters listed in Table 4. Use model 6VV1 with drives rated for 3 ADC or below, and model 20VV1 with drives rated for 10 ADC or below.

Table 4. AC Line Filters

Corcom® Model Number	6VV1	20VV1
Rated Current	6 A	20 A
Inductance	1.8 mH	1.8 mH
Capacitance		
Line to Line	0.8 mF	1.1 mF
Line to Ground	0.01 mF	0.01 mF
Discharge Resistor	330 Kohms	330 Kohms

Wire the AC line filter within 0.25 meters of the drive. The ground connection from the filter must be wired to solid earth ground (resistance less than 500 ohms); not machine ground. This is very important!

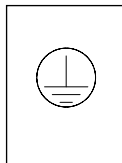

If the end-user is using a CE-approved motor, the correct filter from Table 4 is all that is necessary to meet the EMC directives listed herein.

Armature Filters

If the end-user is not using a CE-approved motor, a second filter on the armature must be deployed. See Table 5 for recommended armature filters. Use model CE04RG with drives rated for 3 ADC or below, and model CE20RG with drives rated for 20 ADC or below.

Table 5. Armature Filters

Minarik® Model Number	CE04RG	CE20RG
Rated Current	4 A	20 A
Inductance	1200 mH	
Capacitance (C1 and C2)	0.1 mF @ 400W VDC	
Discharge Resistor	680KW	

Wire the armature filter to the DC output of the drive, as close to the drive as possible. The ground connection from the filter must be wired to solid earth ground (resistance less than 500 ohms); not machine ground. This is very important!

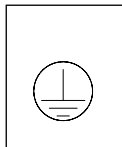

The end user must use the filtration listed in this addendum to comply with CE. The OEM may choose to provide alternative filtering that encompasses the Minarik drive and other electronics within the same panel. The OEM has this liberty because CE is a machinery directive.

Whether or not every component in the OEM's machinery meets CE, the OEM must still submit his machine for CE approval. Thus, no component must necessarily meet CE within the machine, as long as the OEM takes the necessary steps to guarantee the machine does meet CE. By the same token, even if every component in the OEM's machine does meet CE, the machine will not necessarily meet CE as a machine.

Using CE-approved wiring practices (like proper shielding) and the filters should assure the drive will meet EN55014 (1993 emissions standard) and EN50082-1 (1992 immunity standard).

Index

Calibration 23

- CURRENT STAB 30
- DB 29
- FWD ACC 28
- FWD TQ 25
- IR COMP 27
- MAX SPD 29
- REV ACC 28
- REV TQ 26
- VOLTAGE STAB 30

Certificate of Compliance 38

- AC Line Filters 39
- Armature Filters 40
- End User Responsibilities 38

Dimensions 2

Installation 3

- Connections 8
 - Field output connections 16
 - Motor Over-Temperature Switch 13
 - Optional Speed Adjustment Potentiometer Connections 12
 - Power, fuse and motor connections 8
 - Line fuse 9
 - Motor 8
 - Power input 9
 - Run/Brake Switch 14

Start and Stop Switches 13

Heat sinking 6

Mounting 3

Speed adjust potentiometer installation 6

Wiring 4

Shielding guidelines 5

Operation 17

Before Applying Power 17

Drive startup and shutdown 18

Line Starting and Line Stopping 22

Tachogenerator Feedback 19

Calculating the Feedback Resistor Value 19

Safety Warnings i

Specifications 1

Troubleshooting 32

Replacement Parts 37

Unconditional Warranty 44

Notes

Unconditional Warranty

A. Warranty

Minarik Corporation (referred to as "the Corporation") warrants that its products will be free from defects in workmanship and material for twelve (12) months or 3,000 hours, whichever comes first, from date of manufacture thereof. Within this warranty period, the Corporation will repair or replace, at its sole discretion, such products that are returned to Minarik Corporation, 901 East Thompson Avenue, Glendale, CA 91201-2011 USA.

This warranty applies only to standard catalog products, and does not apply to specials. Any returns for special controls will be evaluated on a case-by-case basis. The Corporation is not responsible for removal, installation, or any other incidental expenses incurred in shipping the product to and from the repair point.

B. Disclaimer

The provisions of Paragraph A are the Corporation's sole obligation and exclude all other warranties of merchantability for use, express or implied. The Corporation further disclaims any responsibility whatsoever to the customer or to any other person for injury to the person or damage or loss of property of value caused by any product that has been subject to misuse, negligence, or accident, or misapplied or modified by unauthorized persons or improperly installed.

C. Limitations of Liability

In the event of any claim for breach of any of the Corporation's obligations, whether express or implied, and particularly of any other claim or breach of warranty contained in Paragraph A, or of any other warranties, express or implied, or claim of liability that might, despite Paragraph B, be decided against the Corporation by lawful authority, the Corporation shall under no circumstances be liable for any consequential damages, losses, or expense arising in connection with the use of, or inability to use, the Corporation's product for any purpose whatsoever.

An adjustment made under warranty does not void the warranty, nor does it imply an extension of the original 12-month warranty period. Products serviced and/or parts replaced on a no-charge basis during the warranty period carry the unexpired portion of the original warranty only.

If for any reason any of the foregoing provisions shall be ineffective, the Corporation's liability for damages arising out of its manufacture or sale of equipment, or use thereof, whether such liability is based on warranty, contract, negligence, strict liability in tort, or otherwise, shall not in any event exceed the full purchase price of such equipment.

Any action against the Corporation based upon any liability or obligation arising hereunder or under any law applicable to the sale of equipment or the use thereof, must be commenced within one year after the cause of such action arises.



901 E Thompson Avenue
Glendale, CA 91201-2011
Tel.: 1-800-MINARIK (646-2745)
Fax: 1-800-394-6334
www.minarikcorp.com

Document Number 250-0096, Revision 4
Printed in the U.S.A – 12/00
U.S.A. \$10.00, Outside U.S.A. \$11.00