



# USER'S MANUAL

**Models:**

**MM101U**

**MM201U**

SCR, Adjustable Speed Drives for DC Brush Motors

Copyright © 2001 by  
Minarik Corporation

All rights reserved. No part of this manual may be reproduced or transmitted in any form without written permission from Minarik Corporation. The information and technical data in this manual are subject to change without notice. Minarik Corporation and its Divisions make no warranty of any kind with respect to this material, including, but not limited to, the implied warranties of its merchantability and fitness for a given purpose. Minarik Corporation and its Divisions assume no responsibility for any errors that may appear in this manual and make no commitment to update or to keep current the information in this manual.

Printed in the United States of America.

# Safety Warnings



- This symbol  denotes an important safety tip or warning. **Please read these instructions carefully** before performing any of the procedures contained in this manual.
- **DO NOT INSTALL, REMOVE, OR REWIRE THIS EQUIPMENT WITH POWER APPLIED.** Have a qualified electrical technician install, adjust and service this equipment. Follow the National Electrical Code and all other applicable electrical and safety codes, including the provisions of the Occupational Safety and Health Act (OSHA), when installing equipment.
- Reduce the chance of an electrical fire, shock, or explosion by proper grounding, over-current protection, thermal protection, and enclosure. Follow sound maintenance procedures.



**It is possible for a drive to run at full speed as a result of a component failure.** Minarik strongly recommends the installation of a master switch in the main power input to stop the drive in an emergency.

**Circuit potentials are at 115 VAC or 230 VAC above earth ground.** Avoid direct contact with the printed circuit board or with circuit elements to prevent the risk of serious injury or fatality. Use a non-metallic screwdriver for adjusting the calibration trimpots. Use approved personal protective equipment and insulated tools if working on this drive with power applied.

---

# Contents

<b>Specifications</b>	<b>1</b>
<b>Dimensions</b>	<b>2</b>
<b>Installation</b>	<b>3</b>
Mounting	3
Wiring	4
Shielding guidelines	5
Speed adjust potentiometer connections	6
Heat sinking	7
Line fusing	7
Connections	8
Motor connections	8
Field output	9
Power connections	9
Voltage follower connection	11
<b>Operation</b>	<b>12</b>
Before applying power	12
Drive startup and shutdown	12
To shut down the drive:	13
Reversing	13
Starting and Stopping Methods	13
Line stopping	14
Decelerating to minimum speed	14
Dynamic braking	15
<b>Calibration</b>	<b>17</b>
Calibration procedure	19
MINIMUM SPEED (MIN SPD)	19
MAXIMUM SPEED (MAX SPD)	20
REGULATION (IR COMP)	20

---

TORQUE LIMIT (TORQUE) .....	21
ACCELERATION (ACCEL) .....	22
DECELERATION (DECEL) .....	23
<b>Application Notes</b>	<b>24</b>
FWD-STOP-REV switch .....	24
Reversing with dynamic braking .....	25
Reversing with a DLC600 .....	26
Independent Adjustable Speeds .....	27
Adjustable speeds using potentiometers in series .....	28
Multiple fixed speeds .....	29
RUN/JOG switch .....	30
Leader-follower application .....	31
Single speed potentiometer control of multiple drives .....	32
<b>Troubleshooting</b>	<b>33</b>
Before troubleshooting .....	33
Replacement Parts .....	37
<b>Unconditional Warranty</b>	<b>inside back cover</b>

---

# Illustrations

Figure 1.	Dimensions	.2
Figure 2.	Speed Adjust Potentiometer Installation	.6
Figure 3.	Power, Fuse and Motor Connections	10
Figure 4.	Voltage Follower Connections	11
Figure 5.	Run/Decelerate to Minimum Speed Switch	14
Figure 6.	Dynamic Brake Connection	16
Figure 7.	Calibration Trimpot Layout	18
Figure 8.	FWD-STOP-REV Switch	24
Figure 9.	Reversing Circuit Connection	25
Figure 10.	Reversing with a DLC600	26
Figure 11.	Independent Adjustable Speeds	27
Figure 12.	Adjustable Fixed Speeds Using Potentiometers in Series	28
Figure 13.	Multiple Fixed Speeds	29
Figure 14.	RUN/JOG Switch Connection to Speed Adjust Potentiometer	30
Figure 15.	Leader-Follower Application	31
Figure 16.	Single Speed Potentiometer Control of Multiple Drives	32

# Tables

Table 1.	Replacement Line Fuse Sizes	.8
Table 2.	Field Output Connections	10
Table 3.	Recommended Dynamic Brake Resistor Sizes	16
Table 4.	Replacement Parts	37

# Specifications

<b>Model</b>	<b>Max. Input Voltage (AC)</b>	<b>Max. Input Current (Amps AC)</b>	<b>Armature Current (Amps DC)</b>	<b>HP Range</b>	<b>Style</b>
MM101U	115	10	10	1/4 - 1	Chassis
MM201U	230	10	10	1/2 - 2	Chassis
AC Line Voltage Tolerance			±10%, 50/60 Hz, single phase		
Armature Voltage					
MM101U					0 – 90 VDC
MM201U					0 – 180 VDC
Field Voltage (1 ADC max)					
MM101U					50 – 100 VDC
MM201U					100 – 200 VDC
Maximum Output Field Current					1 ADC
Form Factor				1.37 at base speed	
Accel. Time Range (for 0–90 VDC Armature Voltage)				0.5 – 8 seconds	
Decel. Time Range (for 0-90 VDC Armature Voltage)				0.5 – 8 seconds	
Analog Input Voltage Range for 0–90 VDC Armature Voltage (signal must be isolated; S1 to S2)					
					0 – 5 VDC
Input Impedance (S1 to S2)					100K ohms
Load Regulation				1% base speed or better	
Vibration				0.5G max (0 – 50 Hz)	
				0.1G max (>50 Hz)	
Ambient Temp. Range					10°C – 55°C
Weight					1.5 lb

# Dimensions

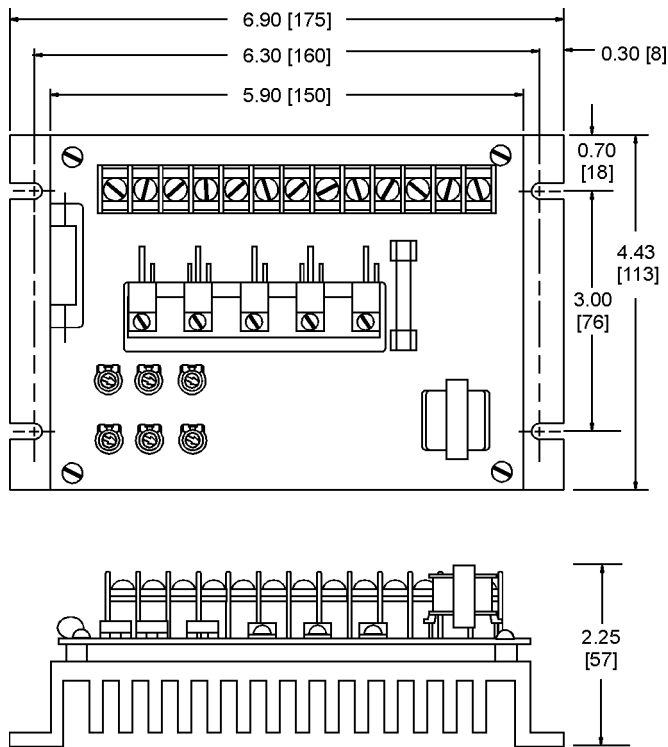

Figure 1. Dimensions

---

# Installation

## Mounting



### Warning

**Do not install, rewire, or remove this control with power applied.** Doing so may cause fire or serious injury. Make sure you have read and understood the Safety Warnings before attempting installation.

The chassis must be earth grounded. Use a star washer beneath the head of at least one of the mounting screws to penetrate the anodized chassis surface and to reach bare metal.

- Drive components are sensitive to electrostatic fields. Avoid direct contact with the circuit board. Hold drive by the chassis only.
- Protect the drive from dirt, moisture, and accidental contact. Provide sufficient room for access to the terminal block and calibration trimpots.
- Mount the drive away from heat sources. Operate the drive within the specified ambient operating temperature range.
- Prevent loose connections by avoiding excessive vibration of the drive.

## Wiring



### Warning



Do not install, remove, or rewire this equipment with power applied. Failure to heed this warning may result in fire, explosion, or serious injury.

Circuit potentials are at 115 or 230 VAC above ground. To prevent the risk of injury or fatality, avoid direct contact with the printed circuit board or with circuit elements.

Do not disconnect any of the motor leads from the drive unless power is removed or the drive is disabled. Opening any one motor lead may destroy the drive.

Use 18–24 AWG wire for speed adjust potentiometer wiring.  
Use 14–16 AWG wire for AC line (L1, L2), field (F1, F2) and motor (A1 and A2) wiring.

---

## Shielding guidelines



### Warning

Under no circumstances should power and logic leads be bundled together. Induced voltage can cause unpredictable behavior in any electronic device, including motor controls.

As a general rule, Minarik recommends shielding of all conductors.

If it is not practical to shield power conductors, Minarik recommends shielding all logic-level leads. If shielding logic leads is not practical, the user should twist all logic leads with themselves to minimize induced noise.

It may be necessary to earth ground the shielded cable. If noise is produced by devices other than the drive, ground the shield at the drive end. If noise is generated by a device on the drive, ground the shield at the end away from the drive. Do not ground both ends of the shield.

If the drive continues to pick up noise after grounding the shield, it may be necessary to add AC line filtering devices, or to mount the drive in a less noisy environment.

## Speed adjust potentiometer connections



### Warning

Be sure that the potentiometer tabs do not make contact with the potentiometer enclosure. Grounding the input will cause damage to the drive.

Install the circular insulating disk between the mounting panel and the 10K ohm speed adjust potentiometer (see Figure 2). Mount the speed adjust potentiometer through a 0.38-inch (10 mm) hole with the hardware provided. Twist the speed adjust potentiometer wires to avoid picking up unwanted electrical noise.

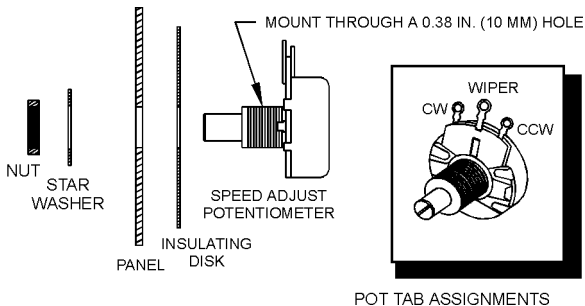

**Figure 2. Speed Adjust Potentiometer Installation**

---

## Heat sinking

All MM101U and MM201U series drives contain sufficient heat sinking in their basic configurations. No additional heat sinking is required.

## Line fusing

MM101U Series drives have a 15-amp line fuse mounted on fuse holder 501 (FU501). MM201U Series drives have two 15-amp line fuses mounted on fuse holders 501 and 502 (FU501 and FU502). When replacing the line fuses, use fast acting fuses rated for 250 VAC or higher, and 150% of the armature current. See Table 1 for recommended line fuse sizes.

**Table 1. Replacement Line Fuse Sizes**

<b>90 VDC Motor Horsepower</b>	<b>180 VDC Motor Horsepower</b>	<b>Max. DC Armature Current (amps)</b>	<b>AC Line Fuse Size (amps)</b>
1/4	1/2	2.6	8
1/3	3/4	3.5	8
1/2	1	5.0	10
3/4	1 1/2	7.6	15
1	2	10.0	15

Minarik Corporation offers fuse kit 050-0073 (5-20A Fuse Kit). See *Replacement Parts* (page 38) for fuse kit contents.

## Connections



### Warning

Do not connect this equipment with power applied. Failure to heed this directive may result in fire or serious injury.

Minarik strongly recommends the installation of a master power switch in the voltage input line. The switch contacts should be rated at a minimum of 200% of motor nameplate current and 250 volts.

Connect the power input leads, field output and DC motor to the drive's terminal board (PCB) as shown in Figure 3 (page 10).

## Motor connections

Minarik drives supply motor voltage from A1 and A2 terminals. It is assumed throughout this manual that, when A1 is positive with respect to A2, the motor will rotate clockwise (CW) while looking at the output shaft protruding from the front of the motor. If this is opposite of the desired rotation, simply reverse the wiring of A1 and A2 with each other.

Connect a DC motor to terminals 8 (A1) and 9 (A2) as shown in Figure 3. **Ensure that the motor voltage rating is consistent with the drive's output voltage.**

## Field output



### Warning

The field output is for shunt wound motors only. Do not make any connections to F1 and F2 when using a permanent magnet motor.

Use 18 AWG wire to connect the field output to a shunt wound motor. See Table 2 for field output connections.

**Table 2. Field Output Connections**

<b>Line Voltage Motor (VAC)</b>	<b>Approximate Field Voltage (VDC)</b>	<b>Connec Field To</b>
115	50	F1 and L1
115	100	F1 and F2
230	100	F1 and L1
230	200	F1 and F2

## Power connections

Connect the AC line power leads to terminals 2 (hot) and 7 (neutral), or to a double-throw, single-pole master power switch (recommended).

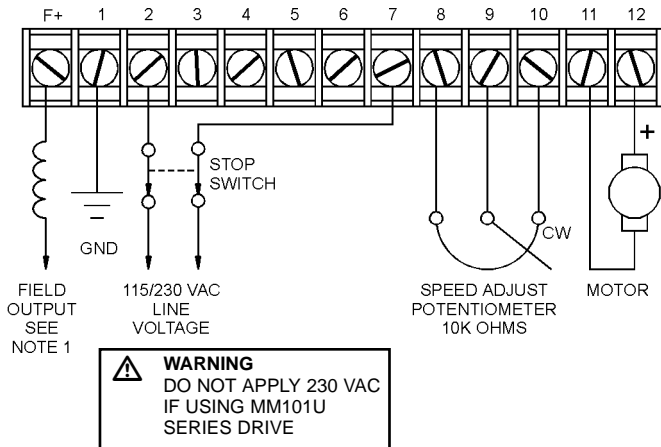
**NOTES:**

1. DO NOT CONNECT FIELD OUTPUT IF USING A PERMANENT-MAGNET MOTOR. REFER TO TABLE 2 (PAGE 9) FOR ALTERNATE FIELD CONNECTIONS.

**Figure 3. Power, Fuse and Motor Connections**

## Voltage follower connection

Instead of using a speed adjust potentiometer, the drive may be wired to follow a 0-5 VDC analog input voltage signal that is isolated from earth ground (Figure 4). Connect the signal input (+) to terminal 9. Connect the signal common (-) to terminal 8. Make no connection to terminal 10.

A potentiometer can be used to scale the analog input voltage. An interface device, such as Minarik model PCM4, may be used to scale and isolate an analog input voltage.

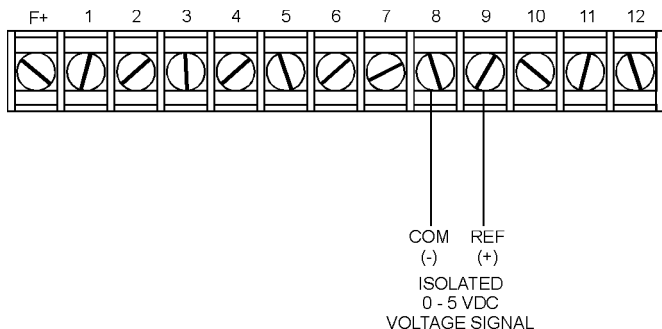

**Figure 4. Voltage Follower Connections**

# Operation



## Warning

Dangerous voltages exist on the drive when it is powered. BE ALERT. High voltages can cause serious or fatal injury.

## Before applying power

- Verify that no conductive material is present on the printed circuit board.
- Verify that the AC supply is properly balanced.

## Drive startup and shutdown

1. Set the reference signal or speed adjust potentiometer to minimum speed.
2. Apply AC line voltage.
3. Slowly turn the speed adjust potentiometer or increase the reference voltage until the desired speed is reached.

## To shut down the drive:

To decelerate the motor from set speed to a stop, set the speed adjust potentiometer to minimum speed. To coast the motor from set speed to a stop, remove AC line voltage from the drive.

## Reversing

Refer to *Application Notes* (page 24) for reversing options, or contact your Minarik sales representative.

## Starting and Stopping Methods



### Warning

For frequent starts and stops, use dynamic braking or decelerating to minimum speed (shorting terminal 8 to terminal 9). Do not use any of these methods for emergency stopping. They may not stop a drive that is malfunctioning. Removing AC line power (both L1 and L2) is the only acceptable method for emergency stopping.

Minarik strongly recommends the installation of an emergency stop switch for chassis drives. The switch contacts should be rated at a minimum of 250 volts and 200% of maximum motor current.

## Line stopping

When AC line voltage is applied to the drive, the motor accelerates to the set speed. When AC line voltage is removed, the motor coasts to a stop. Line stopping (removing AC line voltage) is recommended for stopping in emergency situations only. It is not recommended for frequent starting and stopping.

## Decelerating to minimum speed

The switch shown in Figure 5 may be used to decelerate a motor to a minimum speed. Closing the switch between terminals 8 and 9 decelerates the motor from set speed to a minimum speed determined by the MIN SPD trimpot setting. If the MIN SPD trimpot is set full CCW, the motor decelerates to zero speed when the switch between terminals 8 and 9 is closed. The DECEL trimpot setting determines the rate at which the drive decelerates. By opening the switch, the motor accelerates to set speed at a rate determined by the ACCEL trimpot setting.

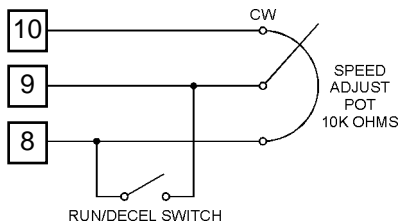

**Figure 5. Run/Decelerate to Minimum Speed Switch**

## Dynamic braking



### Warning

Wait for the motor to completely stop before switching it back to RUN. This will prevent high armature currents from damaging the motor or drive.

Dynamic braking may be used to rapidly stop a motor (Figure 6, page 16). For the RUN/BRAKE switch, use a double-pole, double-throw switch rated for at least the maximum DC armature voltage and maximum braking current.

**Table 3. Recommended Dynamic Brake Resistor Sizes**

<b>Motor Armature Current Rating</b>	<b>Minimum Dynamic Brake Resistor Value</b>	<b>Minimum Dynamic Brake Resistor Wattage</b>
Less than 2 ADC	1 ohm	1W
2–3 ADC	5 ohm	5W
3–5 ADC	10 ohm	10W
5–10 ADC	20 ohm	20W
10–17 ADC	40 ohm	50W

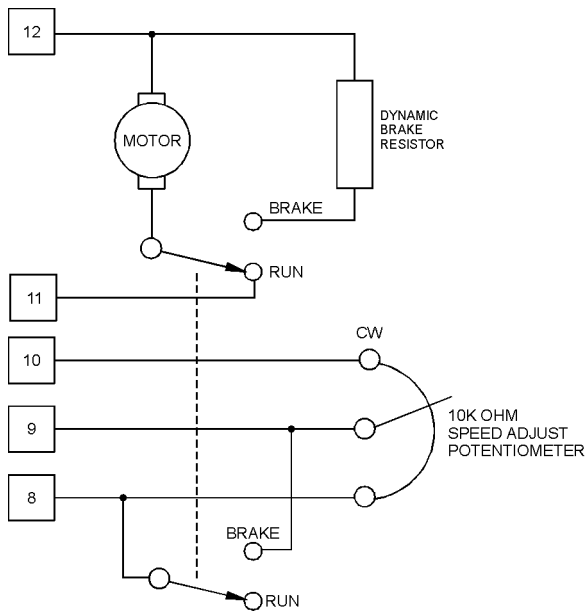

**Figure 6. Dynamic Brake Connection**

---

# Calibration



## Warning

Dangerous voltages exist on the drive when it is powered. When possible, disconnect the voltage input from the drive before adjusting the trimpots. If the trimpots must be adjusted with power applied, use insulated tools and the appropriate personal protection equipment. **BE ALERT.** High voltages can cause serious or fatal injury.

MM101U and MM201U Series drives have six user-adjustable trimpots. Each drive is factory calibrated to its maximum current rating. Readjust the calibration trimpot settings to accommodate lower current rated motors. See Figure 7 (page 18) for trimpot location.

All adjustments increase with CW rotation and decrease with CCW rotation. Use a non-metallic screwdriver for calibration. Each trimpot is identified on the printed circuit board.

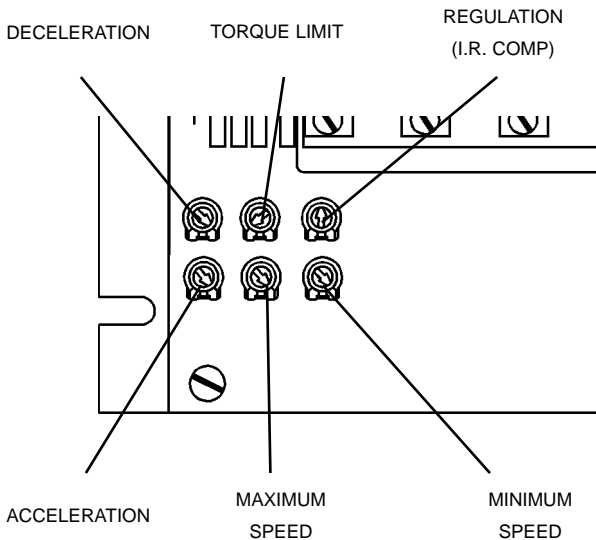

**Figure 7. Calibration Trimpot Layout**

---

## Calibration procedure

Calibrate the drive using the following procedure:

1. Set the MIN SPD, MAX SPD, ACCEL and DECEL trimpots to zero (full CCW).
2. Set the TORQUE LIMIT trimpot to maximum (full CW).
3. Set the IR COMP trimpot to midrange (approximate 12 o'clock position).
4. Set the signal input (analog voltage signal or speed adjust potentiometer) to zero.
5. Apply power to the drive.
6. Calibrate the trimpots as follows:

### MINIMUM SPEED (MIN SPD)

The MIN SPD setting determines the motor speed when the speed adjust potentiometer is turned full CCW. It is factory set for zero speed.

To calibrate, set the MIN SPD trimpot full CCW. Set the speed adjust potentiometer or reference signal to minimum. Adjust the MIN SPD trimpot until the desired minimum motor speed is reached.

## **MAXIMUM SPEED (MAX SPD)**

The MAX SPD setting determines the motor speed when the speed adjust potentiometer is turned full CW. It is factory set for maximum rated speed.

To calibrate, set the MAX SPD trimpot full CCW. Set the speed adjust potentiometer or reference voltage to maximum. Adjust the MAX SPD trimpot until the desired maximum motor speed is reached.

## **REGULATION (IR COMP)**

The IR COMP trimpot setting determines the degree to which motor speed is held constant as the motor load changes. It is factory set for optimum motor regulation.

To calibrate IR COMP (exact calibration):

1. Turn the IR COMP trimpot full CCW.
2. Set the speed adjust potentiometer until the motor runs at midspeed without load (for example, 900 RPM for an 1800 RPM motor) A hand held tachometer may be used to measure motor speed.
3. Load the motor armature to its full load armature current rating. The motor should slow down.
4. While keeping the load on the motor, rotate the IR COMP trimpot until the motor runs at the speed measured in step 2.

---

## TORQUE LIMIT (TORQUE)



### Warning

Although TORQUE LIMIT is set to 120% of maximum drive current rating, continuous operation beyond that rating may damage the motor. If you intend to operate beyond the rating, contact your Minarik representative for assistance.

The TORQUE setting determines the maximum torque for accelerating and driving the motor. TORQUE is factory set at 120% of maximum drive current. You must recalibrate the TORQUE setting if using a lower current motor.

1. With no power applied to the drive, connect a DC ammeter in series with the motor armature.
2. Set the TORQUE LIMIT trimpot to full CCW.
3. Carefully lock the motor armature. Ensure that the motor is firmly mounted.
4. Apply line power. The motor should be stopped.
5. Set the speed potentiometer or reference signal to maximum speed. The motor should remain stopped.
6. Slowly rotate the TORQUE trimpot clockwise (CW) until the ammeter reads 120% of maximum motor armature current.
7. Set the speed adjust potentiometer or reference signal to zero speed.
8. Remove power from the drive.
9. Remove the lock from the motor shaft.
10. Remove the ammeter in series with the motor armature.

## ACCELERATION (ACCEL)

The ACCEL setting determines the time the motor takes to ramp to a higher speed. See *Specifications* on page 1 for approximate acceleration times. ACCEL is factory set for the fastest acceleration time (full CCW).

To set the acceleration time:

1. Set the speed adjust potentiometer or reference signal to minimum. The motor should run at minimum speed.
2. Set the speed adjust potentiometer or reference signal to maximum and measure the time it takes the motor to go from minimum to maximum speed.
3. If the time measured in step 2 is not the desired acceleration time, turn the ACCEL trimpot CW for a slower acceleration time, or CCW for a faster acceleration time. Repeat steps 1 through 3 until the acceleration time is correct.

## DECELERATION (DECEL)

The DECEL setting determines the time the motor takes to ramp to a lower speed. See *Specifications* on page 1 for approximate deceleration times. DECEL is factory set for the fastest deceleration time (full CCW).

To set the deceleration time:

1. Set the speed adjust potentiometer or reference signal to maximum. The motor should run at maximum speed.
2. Set the speed adjust potentiometer or reference signal to minimum and measure the time it takes the motor to go from maximum to minimum speed.
3. If the time measured in step 2 is not the desired deceleration time, turn the DECEL trimpot CW for a slower deceleration time, or CCW for a faster deceleration time. Repeat steps 1 through 3 until the deceleration time is correct.

# Application Notes

## FWD-STOP-REV switch

Use a single-pole, three-position switch with a single speed adjust potentiometer to coast to a stop between reversals (Figure 8). Set the switch to the center position to decelerate the motor to a stop. The switch contacts should be rated at a minimum of 250 volts and 150% to 200% of motor nameplate current.

Wait for the motor to come to a stop before switching to either the forward or reverse direction. This will prevent high armature currents from damaging the motor or drive.

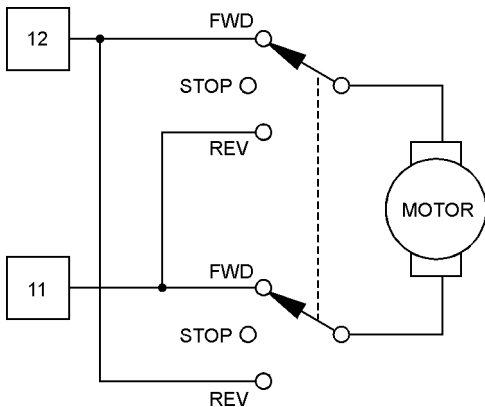

**Figure 8. FWD-STOP-REV Switch**

## Reversing with dynamic braking

A dynamic brake may be used when reversing the motor direction (Figure 9). Use a three-pole, three-position switch rated for at least the maximum DC armature voltage and maximum braking current. Wait for the motor to stop completely before switching it to either the forward or reverse direction.

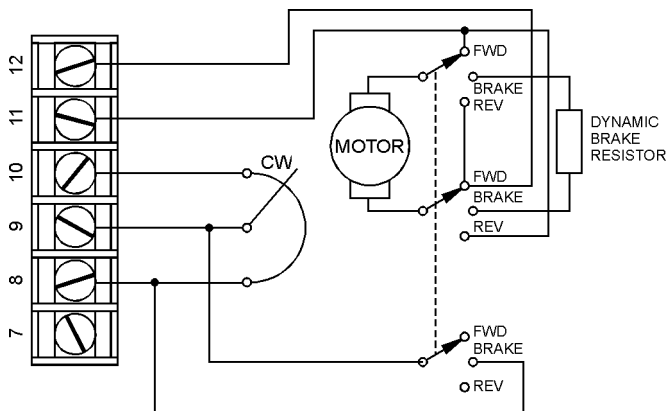

Figure 9. Reversing Circuit Connection



## Independent Adjustable Speeds

Connect two speed adjust potentiometers with a single pole two position switch to select between two independent speeds shown in the forward direction (Figure 11). The speed adjust potentiometers can be mounted at two separate operating stations.

**NOTE:** The total parallel resistance must equal 10K ohms.

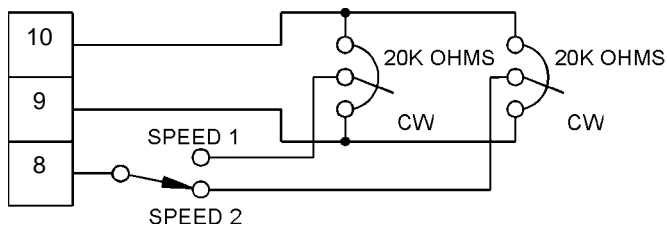
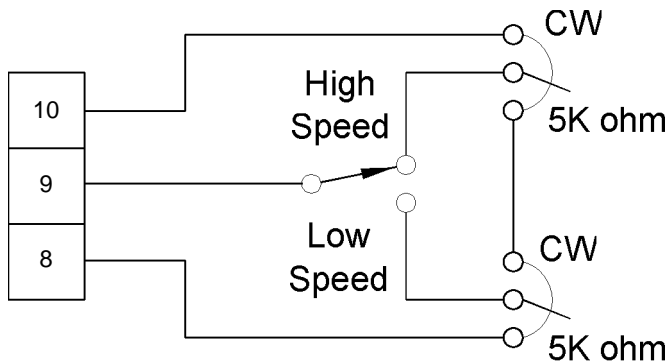

Figure 11. Independent Adjustable Speeds

## Adjustable speeds using potentiometers in series

Replace the speed adjust potentiometer with a single-pole, multi-position switch, and two or more potentiometers in series, with a total series resistance of 10K ohms. Figure 12 shows a connection for fixed high and low speed adjust potentiometers.



**Figure 12. Adjustable Fixed Speeds  
Using Potentiometers in Series**

## Multiple fixed speeds

Replace the speed adjust potentiometer with series resistors with a total series resistance of 10K ohms (Figure 13). Add a single pole, multi-position switch with the correct number of positions for the desired number of fixed speeds.

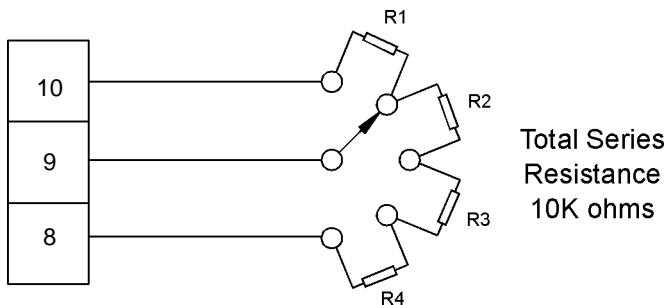

**Figure 13. Multiple Fixed Speeds**

## RUN/JOG switch

Using a RUN/JOG switch is recommended in applications where quick stopping is not needed and frequent jogging is required. Use a single pole, two position switch for the RUN/JOG switch, and a single pole, normally closed, momentary operated pushbutton for the JOG pushbutton as shown in Figure 14. When the RUN/JOG switch is set to JOG, the motor decelerates to minimum speed. Press the JOG pushbutton to jog the motor. Return the RUN/JOG switch to RUN for normal operation.

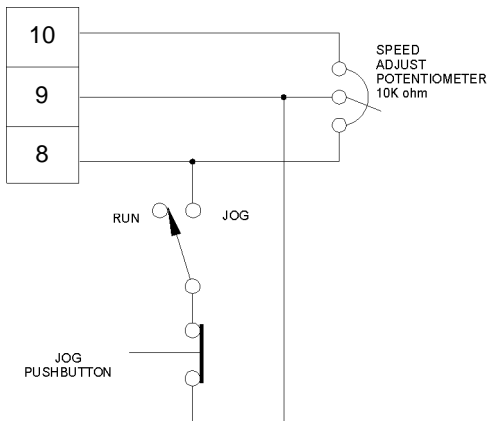

**Figure 14. RUN/JOG Switch Connection to Speed Adjust Potentiometer**

## Leader-follower application

In this application, use a PCM4 to monitor the speed of the leader motor (Figure 15). The PCM4 isolates the leader motor from the follower drive, and outputs a voltage proportional to the leader motor armature voltage. The follower drive uses this voltage reference to set the speed of the follower motor. An optional ratio potentiometer may be used to scale the PCM4 output voltage.

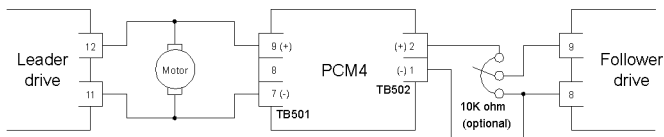

**Figure 15. Leader-Follower Application**

## Single speed potentiometer control of multiple drives

Multiple drives can be controlled with a single speed adjust potentiometer using a PCM4 at the input of each drive to provide isolation (Figure 16). Optional ratio potentiometers can be used to scale the PCM4 output voltage, allowing independent control of each drive.

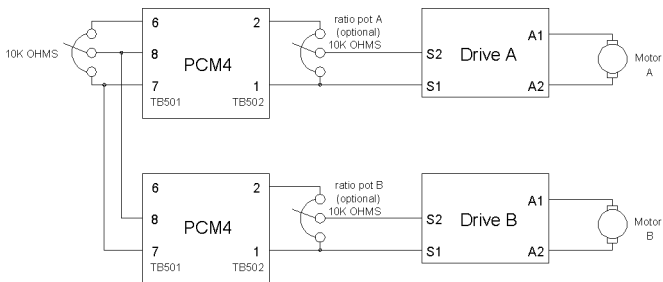

**Figure 16. Single Speed Potentiometer Control of Multiple Drives**

---

# Troubleshooting



## Warning

Dangerous voltages exist on the drive when it is powered. When possible, disconnect the drive while troubleshooting. High voltages can cause serious or fatal injury.

## Before troubleshooting

Perform the following steps before starting any procedure in this section:

- Disconnect AC line voltage from the drive.
- Check the drive closely for damaged components.
- Check that no conductive or other foreign material has become lodged on the printed circuit board.
- Verify that every connection is correct and in good condition.
- Verify that there are no short circuits or grounded connections.
- Check that the drive's rated armature outputs are consistent with the motor ratings.

For additional assistance, contact your local Minarik distributor, or the factory direct:

Phone: (800) MINARIK (646-2745) or Fax: (800) 394-6334

<b>Symptom</b>	<b>Possible Causes</b>	<b>Suggested Solutions</b>
Line fuse blows	<ol style="list-style-type: none"> <li>1. Line fuses are the wrong size.</li> <li>2. Motor cable or armature is shorted to ground.</li> <li>3. Nuisance tripping caused by a combination of ambient conditions and high-current spikes.</li> <li>4. Field circuit is shorted.</li> </ol>	<ol style="list-style-type: none"> <li>1. Check that line fuses are the proper size.</li> <li>2. Check motor cable and armature for shorts.</li> <li>3. Add a blower to cool the drive components; decrease TORQUE settings, <b>or</b> resize motor and drive for actual load demand, <b>or</b> check for incorrectly aligned mechanical components or “jams”. See page 21 for information on adjusting the TORQUE trimpot.</li> <li>4. Send in drive to Minarik repair department.</li> </ol>
Line fuse does not blow, but the motor does not run	<ol style="list-style-type: none"> <li>1. Speed adjust potentiometer or reference signal is set to zero speed.</li> <li>2. Speed adjust potentiometer or reference signal connections are open.</li> </ol>	<ol style="list-style-type: none"> <li>1. Increase speed adjust potentiometer or reference signal setting.</li> <li>2. Check that the speed adjust potentiometer or reference signal connections are not open.</li> </ol>

<b>Symptom</b>	<b>Possible Causes</b>	<b>Suggested Solutions</b>
Line fuse does not blow, but the motor does not run (cont.)	3. Drive is overloaded.  4. Drive is not receiving AC line voltage.  5. Motor is not connected.	3. Verify that the motor is not jammed. Increase TORQUE LIMIT setting (page 21).  4. Apply AC line voltage to L1 and L2.  5. Connect motor to terminals 11 and 12.
Motor runs too fast at maximum speed setting	1. MIN SPD and MAX SPD settings are too high.  2. Field connections are loose (shunt-wound motors only)	1. Recalibrate MIN SPD (page 19) and MAX SPD (page 20).  2. Check field connections.
Motor runs too slow or too fast	MIN SPD and MAX SPD are not calibrated.	1. Recalibrate MIN SPD (page 19) and MAX SPD (page 20).
Motor will not reach the desired speed.	1. MAX SPD setting is too low.  2. IR COMP setting is too low.  3. Motor is overloaded.	1. Increase MAX SPD setting (page 20).  2. Increase IR COMP setting (page 20).  3. Check motor load. Resize the motor and drive if necessary.

<b>Symptom</b>	<b>Possible Causes</b>	<b>Suggested Solutions</b>
Motor pulsates or surges under load	<ol style="list-style-type: none"><li>1. IR COMP is set too high.</li><li>2. Control is in current limit mode.</li></ol>	<ol style="list-style-type: none"><li>1. Adjust the IR COMP setting slightly CCW until the motor speed stabilizes (page 20).</li><li>2. Check that motor is of sufficient horsepower and amperage.</li></ol>

## Replacement Parts

Replacement parts are available from Minarik Corporation and its distributors for this drive series.

**Table 4. Replacement Parts**

<b><u>REFERENCE</u></b>	<b><u>PART NO.</u></b>	<b><u>DESCRIPTION</u></b>
BR	073-0003	W06M 1 AMP FULL WAVE BRIDGE
C1 - C2	011-0027	220 MFD 16 VDC
C3-C5	011-0002	1.0 MFD 35 VDC TANTALUM
C6-C7	010-0014	0.01 MFD 50 VOLT
C8	010-0021	0.022 MFD 50 VOLT
C9	010-0027	0.1 MFD 50 VOLT
C10	010-0050	0.47 MFD 50 VOLT
C11	010-0051	0.047 MFD 50 VOLT
C12-C13	011-0002	1.0 MFD 35 VDC TANTALUM
C14-C16	010-0032	0.1 MFD 250 VOLT
D1	071-0012	1N5397 1 AMP 600 VOLT DIODE
D245	071-0024	1N914 DIODE
D6-D8	071-0029	6020L 20 AMP 600 VOLT DIODE
D9-D10	071-0024	1N914 DIODE
D11-D12	071-0007	1N5406 DIODE
FU1	050-0018	15 AMP 3AB ANTI-VIBRATION FUSE
FU2	050-0018	15 AMP 3AB ANTI-VIBRATION FUSE (MM201U ONLY)
IC1	061-0002	78L05 +5 VOLT REGULATOR
IC2	061-0003	79L05 -5 VOLT REGULATOR
IC3	060-0028	LM324 OP AMP
IC4	060-0052	LM358 DUAL OP AMP
MOV1-MOV2	075-0002	V130LA10A TRANSIENT SUPPRESSOR (MM101U)

<u>REFERENCE</u>	<u>PART NO.</u>	<u>DESCRIPTION</u>
MOV1-MOV2	075-0001	V250LA15A TRANSIENT SUPPRESSOR (MM201U)
P1	120-0023	10K OHM 5 WATT POT
P2-P3	121-0024	25K OHM 1/4 WATT POT
P4	121-0021	1 MEG OHM 1/4 WATT POT
P5-P6	121-0024	25K OHM 1/4 WATT POT
P7	121-0021	1 MEG OHM 1/4 WATT POT
Q1	070-0010	2N5354 OR 2N3638
Q2	070-0022	2N4401
R1	030-0021	10K OHM 1/4 WATT
R2	030-0028	100K OHM 1/4 WATT 5%
R3	030-0021	10K OHM 1/4 WATT
R4	030-0038	2.2 MEG OHM 1/4 WATT 5%
R5	030-0010	470 OHM 1/4 WATT
R6	030-0028	100K OHM 1/4 WATT 5%
R7	030-0026	47 K OHM 1/4 WATT
R8	030-0008	240 OHM 1/4 WATT
R9-R10	030-0005	100 OHM 1/4 WATT 50X
R11-R12	030-0021	10K OHM 1/4 WATT
R13	030-0016	2.2 K OHM 1/4 WATT
R14	030-0021	10K OHM 1/4 WATT
R15	030-0016	2.2 K OHM 1/4 WATT
R16	030-0028	100K OHM 1/4 WATT 5%
R17	030-0025	33K OHM 1/4 WATT 5%
R18	030-0033	470 OHM 1/4 WATT
R19	030-0028	100K OHM 1/4 WATT 5%
R20	030-0027	68K OHM 1/4 WATT
R21	030-0016	2.2 K OHM 1/4 WATT
R22	030-0026	47K OHM 1/4 WATT
R23	030-0027	68 K OHM 1/4 WATT
R24	030-0038	2.2 MEG OHM 1/4 WATT 5%
R25-R26	030-0036	1 MEG OHM 1/4 WATT (MM101U)
R25-R26	030-0038	2.2 MEG OHM 1/4 WATT 5% (MM201U)

---

<u>REFERENCE</u>	<u>PART NO.</u>	<u>DESCRIPTION</u>
R27-R28	030-0001	22 OHM 1/4 WATT
R29-R30	031-0002	10 OHM 1/2 WATT 10%
SCR1-SCR2	072-0017	S6020L SCR F IGT 3M OR LESS
T 230-0054	DST-2-20	115/230:20V TRANSFORMER
Z 071-0025	IN4733	5.1 VOLT ZENER DIODE

### **202-0003 POTENTIOMETER KIT CONTENTS**

1 EA 10K OHM Potentiometer, 5W, 5% TOL	120-0009
1 EA 3/8-32 X 1/2 NUT	151-0007
1 EA 3/8IN INT TOOTH LOCK WSHR	152-0007
1 EA POT INSULATING WASHER	156-0022

### **050-0073 FUSE KIT CONTENTS**

2 EA 5A 3AG FAST-ACTING FUSE	050-0022
2 EA 8A 3AG FAST-ACTING FUSE	050-0059
2 EA 10A 3AG FAST-ACTING FUSE	050-0024
2 EA 15A 3AG FAST-ACTING FUSE	050-0018
2 EA 20A 3AG FAST-ACTING FUSE	050-0019
1 EA 0.5A PICO FUSE	050-0074

# Notes

## **Unconditional Warranty**

### **A. Warranty**

Minarik Corporation (referred to as "the Corporation") warrants that its products will be free from defects in workmanship and material for twelve (12) months or 3,000 hours, whichever comes first, from date of manufacture thereof. Within this warranty period, the Corporation will repair or replace, at its sole discretion, such products that are returned to Minarik Corporation, 901 East Thompson Avenue, Glendale, CA 91201-2011 USA.

This warranty applies only to standard catalog products, and does not apply to specials. Any returns for special controls will be evaluated on a case-by-case basis. The Corporation is not responsible for removal, installation, or any other incidental expenses incurred in shipping the product to and from the repair point.

### **B. Disclaimer**

The provisions of Paragraph A are the Corporation's sole obligation and exclude all other warranties of merchantability for use, express or implied. The Corporation further disclaims any responsibility whatsoever to the customer or to any other person for injury to the person or damage or loss of property of value caused by any product that has been subject to misuse, negligence, or accident, or misapplied or modified by unauthorized persons or improperly installed.

### **C. Limitations of Liability**

In the event of any claim for breach of any of the Corporation's obligations, whether express or implied, and particularly of any other claim or breach of warranty contained in Paragraph A, or of any other warranties, express or implied, or claim of liability that might, despite Paragraph B, be decided against the Corporation by lawful authority, the Corporation shall under no circumstances be liable for any consequential damages, losses, or expense arising in connection with the use of, or inability to use, the Corporation's product for any purpose whatsoever.

An adjustment made under warranty does not void the warranty, nor does it imply an extension of the original 12-month warranty period. Products serviced and/or parts replaced on a no-charge basis during the warranty period carry the unexpired portion of the original warranty only.

If for any reason any of the foregoing provisions shall be ineffective, the Corporation's liability for damages arising out of its manufacture or sale of equipment, or use thereof, whether such liability is based on warranty, contract, negligence, strict liability in tort, or otherwise, shall not in any event exceed the full purchase price of such equipment.

Any action against the Corporation based upon any liability or obligation arising hereunder or under any law applicable to the sale of equipment or the use thereof, must be commenced within one year after the cause of such action arises.



901 East Thompson Avenue  
Glendale, California 91201-2011

Tel: (800) MINARIK (646-2745)

Fax: (800) 394-6334

[www.minarikcorp.com](http://www.minarikcorp.com)

Document Number 250-0089, Revision 4

Printed in the U.S.A – 5/01

\$12.00 North America, \$13.00 Outside North America