

INSTALLATION INSTRUCTIONS

Model PK 1 **Magnetic Pickup Kit**

Copyright © 1999 by
Minarik Corporation

All rights reserved. No part of this manual may be reproduced or transmitted in any form without written permission from Minarik Corporation. The information and technical data in this manual are subject to change without notice. Minarik Corporation and its Divisions make no warranty of any kind with respect to this material, including, but not limited to, the implied warranties of its merchantability and fitness for a given purpose. Minarik Corporation and its Divisions assume no responsibility for any errors that may appear in this manual and make no commitment to update or to keep current the information in this manual.

Safety Warnings

- Have a qualified electrical maintenance technician install, adjust and service this equipment. Follow the National Electrical Code and all other applicable electrical and safety codes, including the provisions of the Occupational Safety and Health Act (OSHA), when installing equipment.
- Reduce the chance of an electrical fire, shock, or explosion by proper grounding, over-current protection, thermal protection, and enclosure. Follow sound maintenance procedures.



SHOCK
HAZARD



AVOID
HEAT



KEEP
DRY



AVOID
VIBRATION

PK-1 Magnetic Pickup

The PK-1 pickup kit consists of a magnetic sensor with 6-inch electrical wire leads and a pickup wheel with four different bore hubs. The sensor is a non-contact transducer that converts mechanical motion into electrical energy. It is capable of sensing any ferromagnetic material having discontinuities such as gear teeth or slots. The pickup wheel has 30 teeth, operates bi-directionally and can sense direct RPM from 60 to 2500 RPM. It is supplied with hubs of 5/16 inch, 3/8 inch, 1/2 inch, and 5/8 inch bore.

Installing the PK-1 Magnetic Pickup

1. Assemble the pickup wheel hub to the pickup wheel (sprocket) with a small amount of Loctite adhesive. After the Loctite has set, secure the pickup wheel to the driven shaft with the set screw in the pickup wheel hub.
2. For maximum performance the magnetic pickup should be mounted in a nonferrous housing or bracket. In high vibration environments, the mounting must be as rigid as possible to inhibit sensor movement.

3. The magnetic pickup is mounted through a 21/64 inch hole and held in place by two locknuts, one on each side of a mounting bracket. Turn the sensor into the hole until it touches the highest point on the pickup wheel and then back it out to a 0.005 – 0.0010 inch gap. (The gap is best obtained using a feeler gauge.) Secure with the locknuts.

Note: The clearance between the sensor and pickup wheel should be as small as possible for maximum output voltage. This clearance, though, must be sufficient to allow for “wobble” or “run out” in order to avoid pickup damage.

4. Set the programming DIP switches for magnetic pickup and connect the pickup to the VT6 unit as shown on page 7 of user manual 250-0083. ***Note:** To prevent possible electrical interference, do not run pickup cable in the same conduit as the AC line.*

6 Kit Installation Instructions

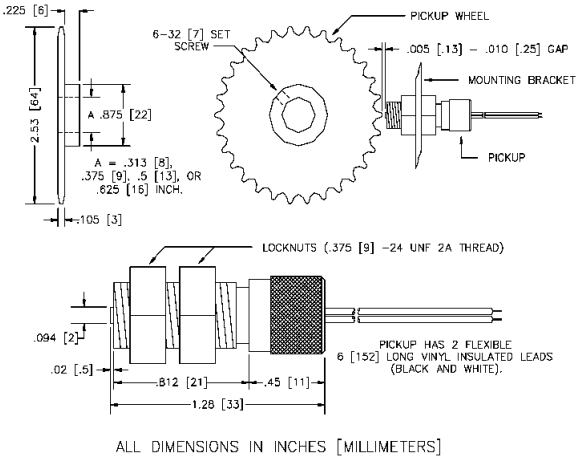

Figure 1. PK1 Dimensions

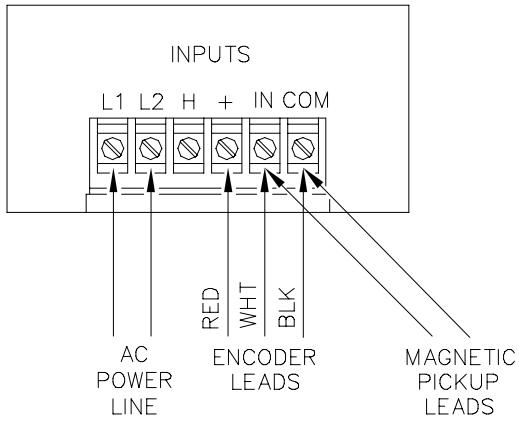

Fig. 3. PK1 Pickup Connection to VT6

Minarik Corporation

901 East Thompson Avenue
Glendale, California 91201-2011

Phone: (818) 502-1528

Fax: (818) 502-0716

www.minarikcorp.com

Document number 250-0041, Revision 2

Printed in the U.S.A – 2/99

\$11.00 U.S.A. – \$12.00 Canada