

# INSTRUCTION MANUAL

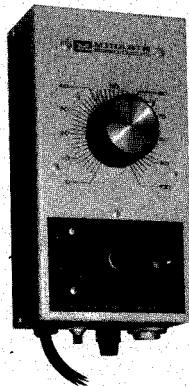

## ADJUSTABLE SPEED CONTROLS MODELS SL32 and SL52



**Minarik Electric**  
**Masters of Control®**



**PRODUCT DATA MANUAL SL32 AND SL52**

**INSTALLATION and OPERATING INSTRUCTIONS  
FOR MODELS SL32 and SL52 MINARIK®  
ADJUSTABLE SPEED CONTROLS for  
BODINE® SHUNT WOUND  
1/20, 1/15 and 1/8 HP 115 VDC MOTORS**

**TABLE OF CONTENTS**

**SECTION 1 - GENERAL INFORMATION ..... 1 thru 2**  
Features and Specifications ..... 1 thru 2  
Dimensional Data ..... 2

**SECTION 2 - INSTALLATION ..... 2 thru 3**  
SAFETY WARNINGS ..... 3  
Minarik® Models SL32 and SL52 ..... 2 thru 3

**SECTION 3 - OPERATING INSTRUCTIONS ..... 3 thru 4**  
Minarik® Models SL32 and SL52 ..... 3 thru 4

**SECTION 4 - CALIBRATION INFORMATION .. 4 thru 7 and 10**  
SAFETY WARNING ..... 4  
Maximum Speed Adjustment ..... 4 thru 5  
Speed Regulation (Adjustable I.R. Compensation) ..... 5  
Current Limiting ..... 5  
Standard Calibration Instructions ..... 5 thru 7 and 10

**SECTION 5 - PARTS LIST ..... 11 thru 12**  
Minarik® Models SL32 and SL52 ..... 11 thru 12

**SECTION 6 - TROUBLE SHOOTING ..... 13 thru 15**  
Minarik® Models SL32 and SL52 ..... 13 thru 15

**SECTION 7 - SCHEMATICS ..... 8 thru 9**  
Minarik® Models SL32 and SL52 ..... 8 thru 9

Disclaimer ..... Inside Back Cover  
Warranty ..... Outside Back Cover



## SECTION 1 - GENERAL INFORMATION

The Models SL32 and SL52 Minarik® adjustable speed controls are full wave, solid state devices that are designed to control and vary the speed of Bodine® 1/20th thru 1/8th HP, 115 VDC shunt wound motors. The SL32 is designed to operate 1/20th and 1/15th HP motors. The SL52 is designed to operate 1/8th HP motors. The controls have choke/capacitor filtering to assure the controlled motor will be extra quiet, smooth and cool running. In a typical application 2% base speed regulation is provided with the help of temperature, line voltage and I.R. compensation. The controls feature a RUN/STOP switch with dynamic braking, controlled acceleration and current limiting. The SL32 has a dual speed range of 36:1 and 50:1. The SL52 has a dual speed range of 35:1 and 41:1. They also have adjustable I.R. compensation and a maximum speed adjustment to limit high speed operation. The Models SL32 and SL52 Minarik® adjustable speed controls are a U.L. (Underwriters Laboratories) recognized component, File E35603.

### FEATURES

- \* RUN/STOP (Dynamic Braking) SWITCH
- \* DUAL SPEED RANGE
- \* CHOKE/CAPACITOR FILTERING
- \* TEMPERATURE COMPENSATION
- \* 2% BASE SPEED REGULATION (Typical Application)
- \* MAXIMUM SPEED ADJUSTMENT
- \* ADJUSTABLE I.R. COMPENSATION
- \* LINE STARTING and STOPPING
- \* LINE VOLTAGE COMPENSATION
- \* FULL WAVE ARMATURE and FIELD SUPPLY
- \* CONTROLLED ACCELERATION
- \* CURRENT LIMITING

### SPECIFICATIONS

INPUT VOLTAGE ..... 115 VAC, 50/60 Hertz Single Phase

MAXIMUM INPUT CURRENT

MODEL SL32 ..... 1.8 Amperes

MODEL SL52 ..... 3.0 Amperes

OUTPUT ARMATURE VOLTAGE ..... 0-115 VDC

## SPECIFICATIONS (Continued)

OUTPUT ARMATURE CURRENT	
MODEL SL32 .....	0.7 Amperes
MODEL SL52 .....	1.2 Amperes
OUTPUT FIELD VOLTAGE .....	100 VDC
OUTPUT FIELD CURRENT .....	0.2 Amperes
WEIGHT .....	3.25 Pounds
AMBIENT TEMPERATURE RANGE .....	10° thru 40° CENTIGRADE

## SECTION 2 - INSTALLATION

### MINARIK® MODELS SL32 AND SL52

The controls are housed in a NEMA 1 enclosure and have a line cord with plug and motor socket at the end of the case. The units may be vertically wall mounted or horizontally bench mounted utilizing the three keyholes on the back of the case (refer to Figure 1-1 below). The units may also be operated without mounting.

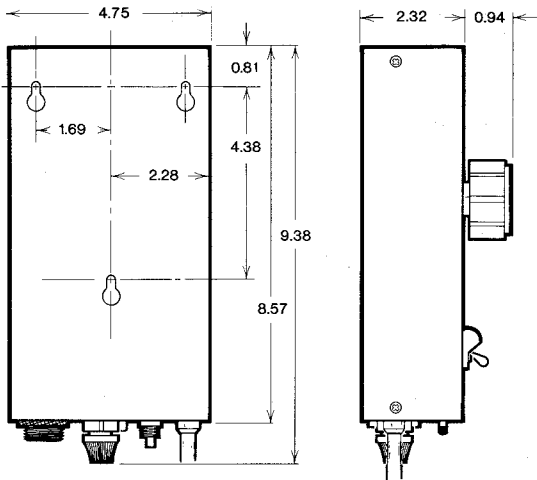

All Dimensions in Inches

Figure 1-1 - SL32 and SL52 MOUNTING DIMENSIONS



leave it on continuously. The maximum torque is obtained in the LO speed range only.

4. Slide the FWD-REV (Forward-Reverse) switch to the desired direction of rotation. FWD gives CW rotation when facing the output shaft with motors cabled by Minarik.

5. Place the RUN/STOP switch in the RUN position and turn speed knob CW to the desired speed.

6. Motor may be started and stopped at any speed setting with the RUN/STOP switch. When placed in the STOP position the motor is dynamically braked to a stop. Motor may be started and stopped with the POWER switch but will coast to a stop.

7. To reverse the motor direction, first stop the motor by using the RUN/STOP switch, and then slide the FWD-REV switch to the desired direction of rotation.

#### SECTION 4 - CALIBRATION INFORMATION

**SAFETY WARNING:** Dangerous voltages exist on the printed circuit board. Contact with components and/or printed circuitry could cause serious injury or fatality. Please refer to and follow the Safety Warnings on page 3.

**IMPORTANT:** A non-metallic screwdriver should be used when adjusting the trim pots to avoid any possibility of the screwdriver's blade contacting live circuitry and shorting the circuitry or allowing contact with any dangerous or fatal voltages.

##### MAXIMUM SPEED, SPEED REGULATION (I.R. COMPENSATION) and CURRENT LIMITING

Three potentiometers, located on the control PC board, are provided for adjustment of the maximum motor speed, regulation of the motor provided with the system and limitation of output current.

1. MAXIMUM SPEED - This feature is provided to allow the motor speed to be adjusted between 75 to 120% of motor name

plate rated speed when the speed adjust knob is set at maximum.

2. SPEED REGULATION (ADJUSTABLE I.R. COMPENSATION) - Regulation is obtained by circuitry which raises the armature voltage to maintain speed when increased loading tends to slow the motor down.

3. CURRENT LIMITING - This is provided for protection against excessive armature current with current limited to approximately 250% of full load rating with FACTORY SETTING of the trim pot. Turning the trim pot CCW reduces the armature current. **Note:** Adjusting this trim pot CW to give armature currents higher than the factory setting could cause damage to the PC board components in case of motor overload or stall.

#### STANDARD CALIBRATION for MINARIK® MODELS SL32 and SL52

These controls have been factory calibrated and no further adjustments should be necessary. However, if the controls have been repaired or the user wants to make any changes the below listed procedures should be followed.

1. With the line voltage disconnected, unscrew the heat sink hold down screw on the rear cover of the control (see Figure 4-1 below).

2. Unscrew the two screws on each side of the control.

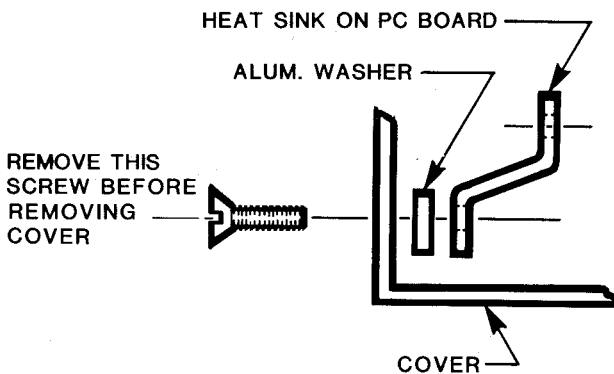

Figure 4-1 - HEAT SINK HOLD DOWN SCREW

3. Remove the rear cover by grasping the sides and carefully pulling it straight off.

4. Set the POWER switch to the OFF position.

5. The direction switch may be set to either FWD or REV.

6. Set the motor RUN/STOP switch to RUN.

7. Set the speed adjust knob to "100" (full CW).

8. Set the MAXIMUM SPEED trim pot to full CCW (refer to Figure 4-2 shown below).

9. Set the SPEED REGULATION trim pot to full CCW (refer to Figure 4-2 shown below).

10. Set the CURRENT LIMITING trim pot to full CCW (it is the unlabeled trim pot in Figure 4-2 shown below).

11. Attach the motor cable plug to the control's motor socket, being careful to key the ridge on the plug into the slot on the socket.

12. Connect a DC voltmeter, 0-150 volts minimum scale, across the armature and a DC ammeter, 0-3 amps minimum scale, in series with the armature (refer to Figure 4-3 on page 7).

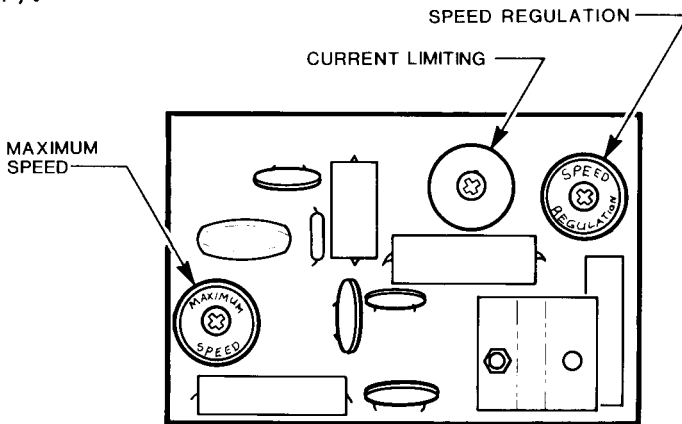

Figure 4-2 - TRIM POT LOCATIONS ON PC BOARD

13. Heed and follow the SAFETY WARNING at the beginning of this section (page 4).

14. With no load on the motor, apply 115 VAC to the control. Then slide the control POWER switch to the LO position.

15. Adjust MAXIMUM SPEED pot to 125 volts at no load.

16. Load the motor to a stall and quickly turn the CURRENT LIMITING trim pot CW until the ammeter reads 1.5 amperes for the SL32 or 2.5 amperes for the SL52.

17. With no load on the motor, turn the front panel speed adjust knob until the voltmeter reads 10 volts.

a. For the SL32, adjust the SPEED REGULATION trim pot until the armature voltage increases from 10 volts at no load to 20 volts when loaded to 0.6 amperes.

b. For the SL52, adjust the SPEED REGULATION trim pot until the armature voltage increases from 10 volts at no load to 16 volts when loaded to 1 ampere.

18. Set power switch to OFF position and disconnect line voltage.

19. Check to see that the aluminum washer, which goes between the control cover and the PC board heat sink (refer to Figure 4-1 on page 5), is aligned over the cover or heat sink screw hole. The aluminum washer has a white substance

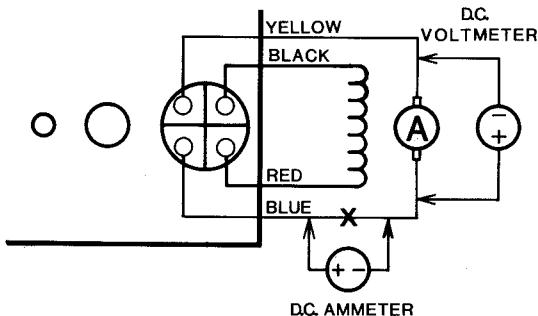
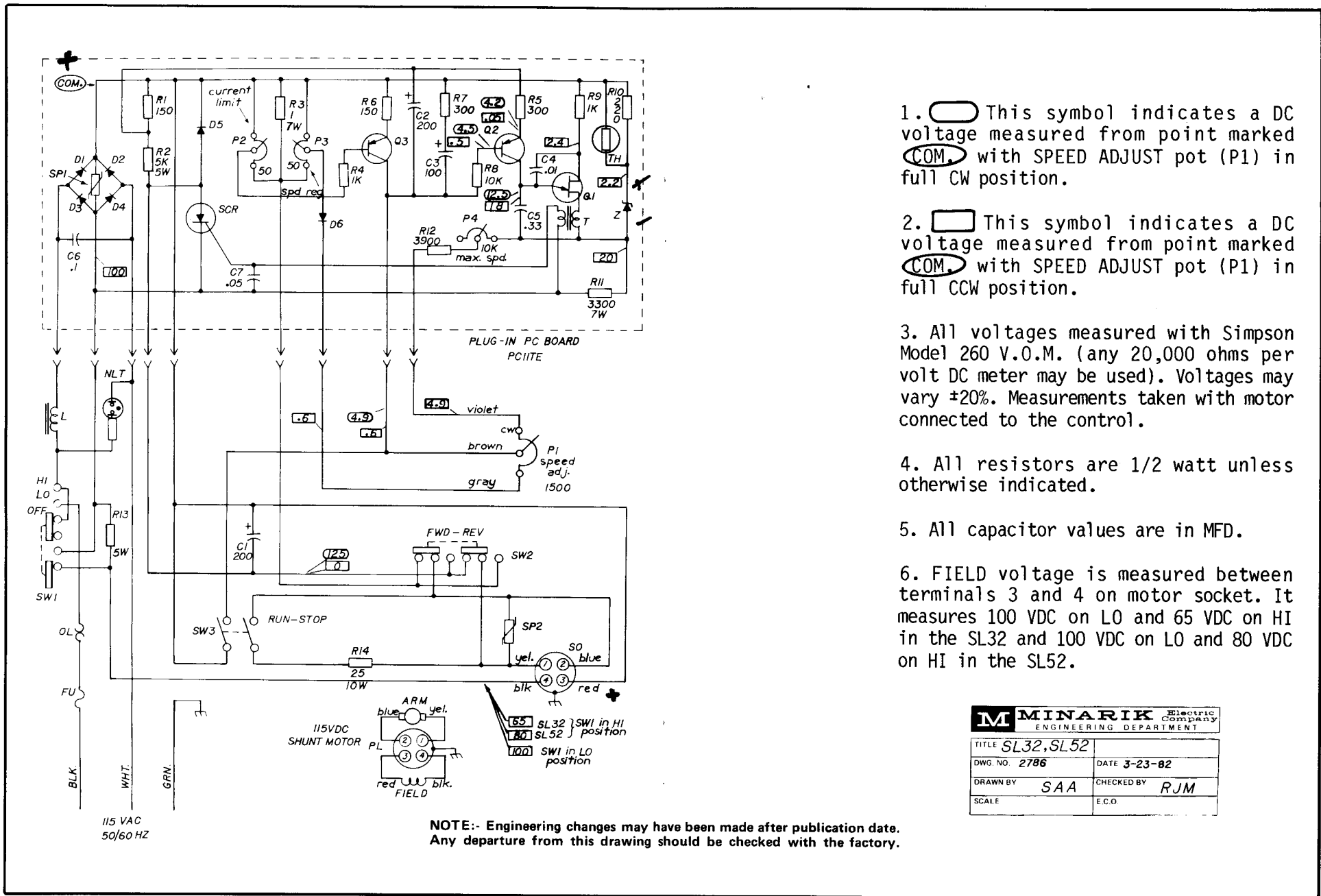



Figure 4-3 - VOLTMETER and AMMETER CONNECTIONS



1.  This symbol indicates a DC voltage measured from point marked **COM.** with SPEED ADJUST pot (P1) in full CW position.

2.  This symbol indicates a DC voltage measured from point marked **COM.** with SPEED ADJUST pot (P1) in full CCW position.

3. All voltages measured with Simpson Model 260 V.O.M. (any 20,000 ohms per volt DC meter may be used). Voltages may vary ±20%. Measurements taken with motor connected to the control.

4. All resistors are 1/2 watt unless otherwise indicated.

5. All capacitor values are in MFD.

6. FIELD voltage is measured between terminals 3 and 4 on motor socket. It measures 100 VDC on LO and 65 VDC on HI in the SL32 and 100 VDC on LO and 80 VDC on HI in the SL52.

<b>M MINARIK</b> Electric Company ENGINEERING DEPARTMENT	
TITLE <b>SL32, SL52</b>	DATE <b>3-23-82</b>
DWG. NO. <b>2786</b>	CHECKED BY <b>RJM</b>
DRAWN BY <b>SAA</b>	E.C.O.
SCALE	

Figure 7-1 - MODELS SL32 and SL52 SCHEMATIC

**SECTION 4 - CALIBRATION INFORMATION**  
**(Continued from page 7)**

on both sides of it and when the cover was removed in step 3, the washer probably stuck to either the cover or the heat sink. Do NOT remove this white material. It is known as "heat sink compound" and is necessary to transfer the SCR generated heat out of the control thru the heat sink to the cover where it can be dissipated into the open air.

20. Carefully slide the cover back into place. Make sure that the aluminum washer is between the cover and the heat sink and replace the heat sink hold down screw.

21. Replace the two cover screws on each side of the control.

## SECTION 5 - PARTS LIST

### MINARIK® MODELS SL32 AND SL52 PARTS LIST

REFERENCE	PART NUMBER	DESCRIPTION
C1	011-0026	250 MFD 200 VDC
C2	011-0025	200 MFD 10 VDC
C3	011-0021	100 MFD 15 VDC
C4	010-0015	0.01 MFD 1K VOLT
C5	010-0037	0.33 MFD 100 VOLT
C6	010-0032	0.1 MFD 500 VOLT
C7	010-0025	0.05 MFD 500 VOLT
D1-D4	071-0007	3 AMP 600 VOLT SILICON DIODES
D5-D6	071-0012	1 AMP 600 VOLT SILICON DIODES
FU	050-0021	3 AMP 3AG NORMAL BLOW FUSE (SL32)
FU	050-0022	5 AMP 3AG NORMAL BLOW FUSE (SL52)
L	240-0006	MINARIK CHOKE
NLT	040-0003	NEON PILOT LIGHT
OL	090-0011	1.8 AMP CIRCUIT BREAKER (SL32)
OL	090-0005	3.0 AMP CIRCUIT BREAKER (SL52)
P1	120-0003	1.5K OHM 5 WATT POT
P2-P3	121-0001	50 OHM 1-1/2 WATT POT
P4	121-0017	10K OHM 1-1/2 WATT POT
Q1	070-0009	2N2646 OR 2N2647
Q2	070-0010	2N5354 OR 2N3638
Q3	070-0013	2N5400
R1	031-0022	150 OHM 1/2 WATT
R2	032-0028	5K OHM 5 WATT
R3	032-0033	1 OHM 7 WATT
R4	031-0026	1K OHM 1/2 WATT
R5	031-0026	300 OHM 1/2 WATT
R6	031-0022	150 OHM 1/2 WATT
R7	031-0026	300 OHM 1/2 WATT
R8	031-0042	10K OHM 1/2 WATT
R9	031-0026	1K OHM 1/2 WATT
R10	031-0024	220 OHM 1/2 WATT
R11	032-0036	3.3K OHM 7 WATT
R12	031-0038	3.9K OHM 1/2 WATT

MINARIK® MODELS SL32 AND SL52 PARTS LIST (Continued)

REFERENCE	PART NUMBER	DESCRIPTION
R13	032-0025	600 OHM 5 WATT (SL32)
R13	032-0024	300 OHM 5 WATT (SL52)
R14	032-0043	25 OHM 10 WATT
SCR	072-0002	8 AMP 400 VOLT SCR
S0	164-0003	4 PIN MOTOR SOCKET
SP1-SP2	075-0002	TRANSIENT SUPPRESSOR
SW1	080-0005	OFF-LO-HI ROCKER SWITCH
SW2	085-0002	DPDT SLIDE SWITCH
SW3	080-0007	DPST TOGGLE SWITCH
T	230-0004	1:1 PULSE TRANSFORMER
TH	033-0001	760 OHM 1% THERMISTOR
Z	071-0002	1N4747 ZENER DIODE
	200-0003-32	COMPLETE SL32 CALIBRATED PC BOARD ASSEMBLY
	200-0003-52	COMPLETE SL52 CALIBRATED PC BOARD ASSEMBLY

## SECTION 6 - TROUBLE SHOOTING

With the enclosed schematic and parts list a trained service technician, by following the below listed procedure, can trouble shoot and find defective parts using only a volt-ohmmeter and a DC ammeter.

Before proceeding check the following:

1. Be sure the line cord is plugged into a wall outlet of the same voltage as that listed on the control nameplate.
2. See that the plug on the motor cable is correctly keyed into the motor socket on the control.
3. Check to see that the line fuse is of the same value as shown on the control nameplate.

I. - Heed and follow the SAFETY WARNING at the beginning of Section 4 on page 4.

II. - Set speed control pot, P1, at zero on the dial, place the motor RUN/STOP switch in the STOP position and then place POWER switch SW1 into L0 range.

A. If pilot light NLT, on the panel does not go on, check:

1. Line fuse, FU.
2. Circuit breaker, OL (press to reset).
3. AC voltage at wall outlet.
4. AC voltage on both sides of power switch, SW1.

III. - If line fuse, FU, blows, place the POWER switch in the OFF position. Unplug the line cord from wall outlet and check:

A. Plug on motor cable may not be correctly keyed into the control's motor socket.

B. Pilot light, NLT, may be shorted.

C. Transient suppressor, SP1 or SP2, may be shorted.

D. One or more of diodes, D1, D2, D3, or D4, may be shorted.

1. Disconnect motor from control socket.

2. Rectifier bridge should have high resistance in both directions across AC terminals.

3. Across field DC terminals resistance should read high in one direction and low in the opposite direction.

4. Across each of the diodes, resistance should read high in one direction and low in the opposite direction.

E. Motor cable or motor field may be shorted or grounded. A resistance reading on the motor cable plug between pins 3 and 4 should read:

1/20 HP	NSH-33	830 Ohms
1/15 HP	NSH-34	950 Ohms
1/8 HP	NSH-54	700 Ohms

IV. - Connect motor cable to control, plug the line cord into wall outlet, set motor RUN/STOP switch in the RUN position and the POWER switch to LO range, advance the speed adjust knob to the maximum setting on the dial:

A. If fuse, FU, blows or circuit breaker, OL, trips:

1. Motor may be overloaded. Place the motor RUN/STOP switch in the STOP position and disconnect load from the motor. Then place motor switch in RUN position, the motor should run at full speed without blowing the fuse or tripping the circuit breaker.

2. Motor armature or motor cable may be shorted or grounded. Disconnect the motor cable. An ohmmeter reading between pins 1 and 2 on the motor cable plug should read approximately 5 to 9 ohms. A reading from either pin to the motor frame should show open (use high ohm scale).

3. Motor field circuit may be open. Check for correct motor field resistance as described in III. E. on page 14.

4. Filter capacitor, C1, may be shorted.

5. A field diode, D1, D2, D3 or D4 may be open, causing the fuse to blow or circuit breaker to trip at no load or very light load because of a high armature current, due to a weak field.

6. Diode, D5 may be shorted.

B. If line fuse does not blow, or circuit breaker does not trip, but motor will not run:

1. Speed adjust potentiometer, P1, may be open.

2. Silicon controlled rectifier, SCR, may be defective.

3. Transistor, Q1, may be defective.

4. Transistor, Q3, may be defective.

5. Filter choke, L, may be open.

6. Zener diode, Z, may be shorted.

V. - If motor runs at high speed regardless of speed control potentiometer setting:

A. Silicon controlled rectifier, SCR, may be shorted.

B. Transistor, Q2, may be shorted.

C. Diode, D6, may be open.

D. Speed adjust potentiometer, P1, may be open.

E. Speed regulation trim pot, P3, may be open.

- - - - - NOTES - - - - -

DISCLAIMER

The information and technical data in this manual are subject to change without notice. Minarik Electric Company and its Divisions make no warranty of any kind with regard to this material, including, but not limited to, the implied warranties of merchantability and fitness for a particular purpose. Minarik Electric Company and its Divisions assume no responsibility for any errors that may appear in this manual and make no commitment to update or to keep current the information in this manual.



Area Code 818 - 502-1528

FAX 1-818-502-9002

901 East Thompson Avenue - Glendale, CA 91201-2011

DOCUMENT NUMBER 250-0008, REVISION 7  
LITHO U.S.A. - 11/87

## LIMITED WARRANTY

**A. WARRANTY:**— Minarik Electric Company warrants that their products will be free from defects in material and workmanship for a period of two (2) years from date of shipment thereof. Within the warranty period Minarik Electric Company will repair or replace such products which are determined by us to be defective and which are returned to Minarik Electric Company, 901 East Thompson Avenue, Glendale, CA 91201-2011 or to the nearest Minarik Authorized Service Station, with shipping charges prepaid. At our option, all return shipments are F.O.B. Minarik Electric Company or its Authorized Service Station. This warranty will not apply to any product which has been subjected to misuse, negligence or accident; or misapplied; or repaired by unauthorized persons; or improperly installed. Minarik is not responsible for removal, installation or any other incidental expenses incurred in shipping the product to or from the repair point.

**B. DISCLAIMER:**— The provisions of paragraph 'A' are Minarik's sole obligation and exclude all other warranties of MERCHANTABILITY or use, express or implied. We further disclaim any responsibility whatsoever to the customer or to any other person for injury to person, or damage to or loss of property of value, caused by any product which has been subjected to misuse, negligence or accident; or misapplied; or modified or repaired by unauthorized persons; or improperly installed.

**C. LIMITATION OF LIABILITY:**— In the event of any claim for breach of any of Minarik's obligations, whether express or implied, and particularly in the event of any claim of a breach of the warranty contained in paragraph 'A', or of any other warranties, express or implied, or claim of liability, which might, despite paragraph 'B', be decided against us by any lawful authority, Minarik Electric Company shall under no circumstances be liable for any consequential damages, losses or expense arising in connection with the use of, or inability to use, our product for any purpose whatsoever. An adjustment made under the warranty does not void the warranty, nor does it imply an extension of the original two (2) years warranty period. Products serviced and/or parts replaced on a no charge basis during the warranty period carry the unexpired portion of the original warranty only.

If for any reason any of the foregoing provisions shall be ineffective, the company's liability for damages arising out of its manufacture or sale of equipment, or use thereof, whether such liability is based on warranty, contract, negligence, strict liability in tort or otherwise, shall not in any event exceed the full purchase price of such equipment.

Any action against the Company based upon any liability or obligation arising hereunder or under any law applicable to the sale of equipment or the use thereof, must be commenced within one year after the cause of such action arises.



**Minarik Electric Co.**  
**Masters of Control®**