

Bravo! An Alternative For Machine Designers



Vent Free Design. No breather or vents to leak! Factory lubricated for life with synthetic, semi-fluid gear lubricant with an operating range of -15°C to 130°C.



NEMA C flange with quill input accepts 56C, 143-5TC and 182-4TC motors.



Bravo™ up to two-thirds lighter and one-third smaller!

Single-piece aluminum alloy housing is vacuum impregnated with Resinol RT (MIL-STD 276) for protection and sealing. No secondary finish required but readily accepts paint. Combines light weight with high tensile strength. Precision machined for alignment of bearings and gearing.

Oversized bearings support positively-retained, high speed shaft for higher shock load capacity — ideal for frequent starting and reversing applications. Premium, Nitrile® high temperature seals each end.

Single-piece alloy steel input shaft and worm shaft. High helix angle worm is case-hardened (Rc 58-60), ground, teeth are profiled and radiused, for noise reduction and enhanced efficiency.

Bronze alloy worm gear is centrifugally cast onto an iron hub for maximum strength, lubricity and superior life.

Oversized bearings for radial load capability and maximum hollow output shaft diameters.

Premium, high-temperature Nitrile® output seals.

Impregnated and machined bearing caps with exterior machined surfaces mate to a variety of mounting accessories. Extra-deep thread engagement provided for greater support strength. Zinc plated hardware.

Hollow output shaft mounting is standard at no extra cost. Reduces total drive envelope size, weight and cost. Solid shaft single and double output is available.



Look Inside the LEESON 182-4T Frame Motor

Fan guard, fan and endshield work together to provide frame-hugging airflow for maximum cooling and over-load capacity. Vents in fan guard meet UL 1/4" articulated probe standard for safe operation.

Cooler running temperatures are achieved by using air guides on the endshield to straighten airflow over the frame for improved heat dissipation and longer insulation life.

Large capacitor housing (single phase) with large MFD capacitors, one molded gasket/joint and simplified wiring.

C face models feature bearing lock to withstand 1000+ lb axial loads. C face endshield designed to handle five times motor weight in overhung load.

Double-strength lifting lug can support ten times the motor weight.

EPACT efficiencies and IRIS™ (Inverter Rated Insulation System) are standard on three phase models. Protects against inverter-generated voltage spikes, efficiency verified by independent laboratory.

Improved operating efficiencies through use of state-of-the-art lamination designs and lamination steels. Die cast rotor is heat-shrunk to shaft.

Endshield design places the bearing load directly over the frame rabbet for excellent radial stiffness and shaft load capabilities. Double shielded bearings (each end) with Shell Dolium R Lubricant.

Endshield stiffening ribs provide increased rigidity to meet demands of high load applications. Cast iron bearing inserts for longer life and quieter operation.

Starting switch and field proven centrifugal device (single phase only) for maximum reliability and performance, even in applications requiring frequent starts.

Large conduit box (steel) and optional box (aluminum) are interchangeable and use the same mounting pattern. Cover lip design reduces contaminate infiltration and enhances dust-tight gasket seal. Box volume exceeds new NEC requirements.

Full fact metal nameplate has connection data, amperage and efficiencies.

Heavy-gauge base is extra-strong and provides reduced flexing and improved structural stiffness.

"Full-opening conduit box" cover makes for easier access to connections. Standard steel box features one 1-3/8" and three 1-1/8" knockouts.

Internal fan of high temperature, glass-filled nylon remains secure—even during the highest temperatures—and provides improved airflow. Reduces "hot spots" and increases insulation life.

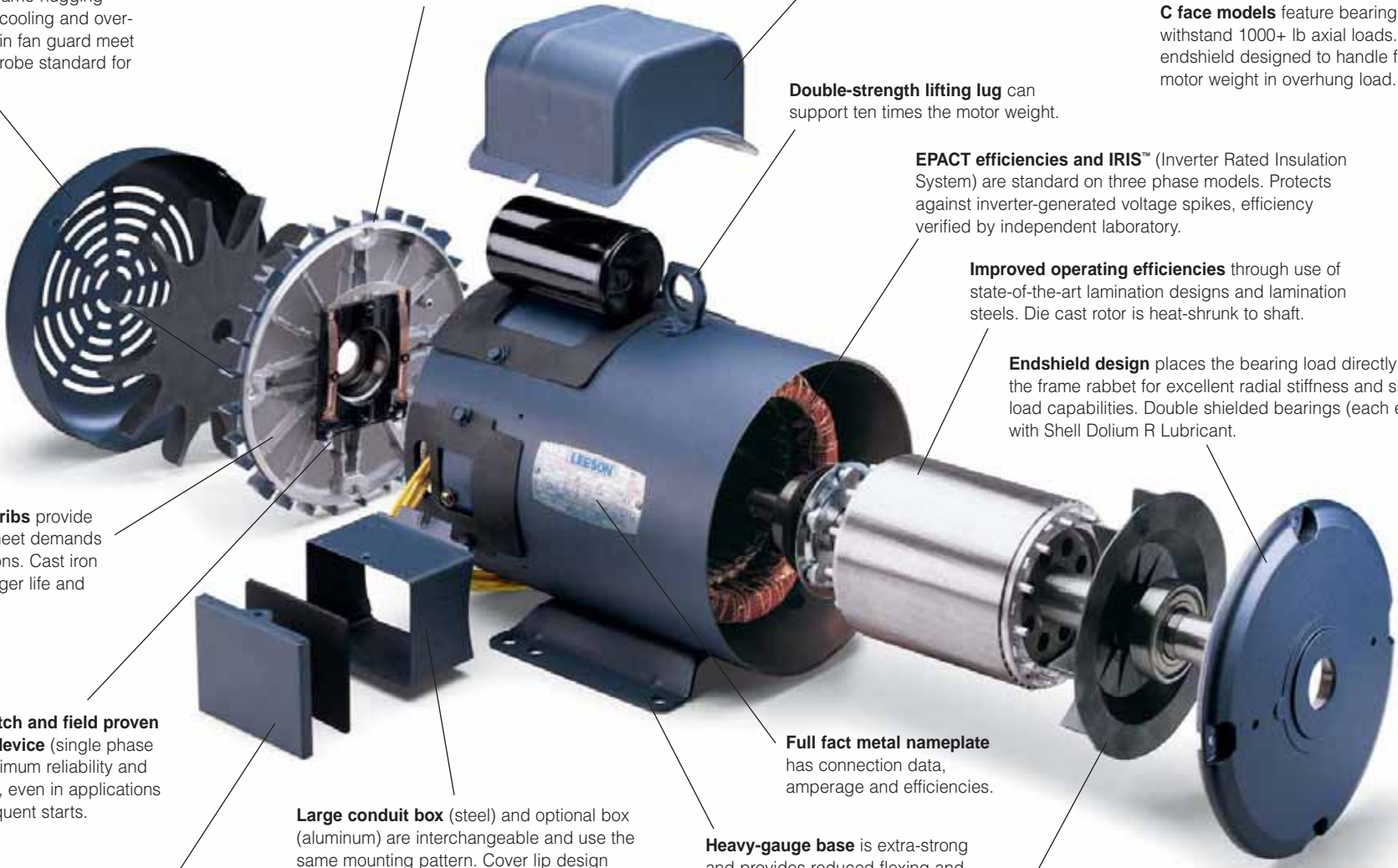

LEESON...Industrial Quality From the Inside Out

Cooling System – quiet, efficient cooling with high volume, chemically inert, static-free fan. Heavy steel fan cover channels air for maximum cooling. Fan positively positioned by opposing flats and snap ring/shoulder for trouble-free operation even in frequent starting applications.

Data Plate – “full fact” metal nameplate has complete information including connection data, amperage and full load efficiency.

Capacitor – molded-case starting capacitor in single phase motors assures high starting torques, adequate for the most demanding loads.

Winding – high temperature, moisture-resistant (MR200° magnet wire) copper winding tied each end, preheated, immersed in Class H polyester varnish and cured, resulting in a stator with vibration and environmental resistance, built-in overload capacity and high full-load, verified efficiencies for energy savings.

Starting Switch – single phase motors use a field-proven rotating mechanism for “three phase” reliability, even in applications requiring frequent starts.

Industrial Design Endshield – internal ribs for rigidity and cast iron bearing inserts for accurate alignment and quiet operation.

Stationary Switch – heavy-duty silver-cadmium oxide contacts and wear pads (single phase only).

Connection Box – generously sized, gasketed conduit box with several access holes and ground screw for easy quick connections to permanently marked leads.

Motor Base & Frame – a heavy-gauge base is electrically welded in multiple locations to a seam-welded steel frame for maximum rigidity and mounting strength.

Overload Protection – thermal overload protectors allow the motor to work at its fullest while providing protection against stall conditions and excessive overload.

Rotor/Shaft Assembly – high pressure cast, void-free rotor is heat shrunk to a precision machined shaft, dynamically balanced for quiet vibration-free operation. Electric motor grade ball bearings used each end. Shell Dolium R lubricant. Internal fan eliminates “hot spots”.

Industrial Design Endshield – heavyweight, deep cross section design endshields, with internal ribs for rigidity and cast iron bearing inserts precision machined for accurate alignment and quiet operation.



LEESON's Inverter Rated Insulation System (IRIS™) provides superior motor protection against voltage spikes induced by variable frequency drives. This total insulation system protects better than spike-resistant magnet wire alone. Specially formed phase insulation, cushioned and sleeved connections (from the leads all the way into the turns), and deep-penetrating, non-hygroscopic, high temperature varnish are just a few features contributing to the extra protection. The IRIS™ total insulation system is standard at no extra cost in all LEESON stock three-phase motors, 1 HP and larger.



Removable inspection cover allows periodic inspection of gearing during routine maintenance.

Ratios up to 63:1 in two-stage units and up to 278:1 in three-stage units to maximize efficiency and reduce overall case size.

Single-piece aluminum alloy housing vacuum impregnated with Resinol RT (MIL-STD 276) for protection and sealing. No secondary finish required but readily accepts paint. Combines light weight with high tensile strength. Precision machined for alignment of bearings and gearing.

Mounting dimensions are interchangeable with many popular reducers, including SEW, David Brown, Nord, Dodge, and Brook Hansen.

Robust output shaft of high strength steel alloy for superior torque and overhung load capacities.

Premium Viton® seals provide extra protection against entry of contaminants or loss of lubrication. Tandem seals available on input and output.

Permanently marked nameplate with output torque, ratio and maximum input horsepower.

Oversized ball bearings on both input and output shafts.

All gearing is hardened and ground (AGMA Class 10 or better), for enhanced efficiency and noise reduction. Double reduction units are 96 – 97% efficient.

LeCENTRIC™ REDUCERS ARE FILLED WITH MOBILGEAR SHC 320 SYNTHETIC OIL as standard. All sizes are considered "lubed for life." Specify mounting position at time of order.

Aluminum NEMA C face input flange (motorized quill input models) with machined fits for precision alignment of motor and bearings.

Bearing spans optimized to allow for maximum overhung load capacity, enhanced durability and reliability—while minimizing shaft deflection.

Removable mounting base allows interchange with dozens of competitive units.

Bolt-on output flange also available to allow interchange with many industry-standard sizes.

