

STYLE BMQ

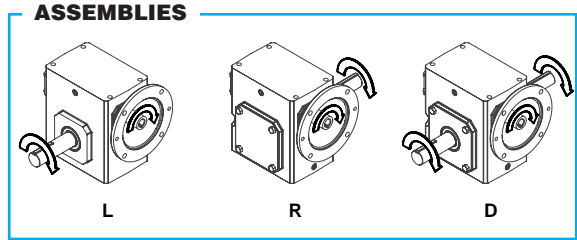
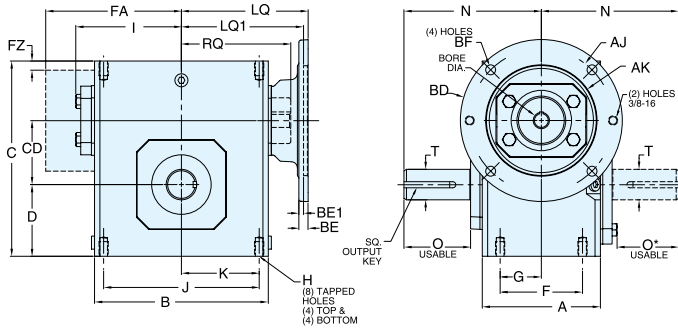

REVERSE ALL ARROWS FOR OPPOSITE INPUT SHAFT ROTATION. CONTACT FACTORY FOR OTHER MOUNTINGS OR ASSEMBLY POSITIONS.

STYLE BMQ DIMENSIONS (Inches)

Series	A	B	C	D	CD	F	G	H		I	J	K	N	O	O*	T +0.000 -0.0015	Output Key
								Tap Size	Depth								
813	2.82	3.80	4.66	1.72	1.33	2.00	1.00	5/16-18 UNC	0.50	2.61	3.25	1.63	4.00	2.16	1.94	0.625	3/16 X 1.38
815	3.44	4.88	5.38	1.91	1.54	2.75	1.38	5/16-18 UNC	0.63	3.14	4.19	2.09	4.31	2.11	1.90	0.750	3/16 X 1.38
818	3.56	5.06	5.75	2.06	1.75	2.75	1.38	5/16-18 UNC	0.63	3.24	4.19	2.09	4.31	2.05	1.84	0.875	3/16 X 1.38
821	3.81	5.80	6.38	2.28	2.06	2.88	1.44	3/8-16 UNC	0.63	3.61	5.00	2.50	4.68	2.29	2.08	1.000	1/4 X 1.44
824	4.06	6.12	6.94	2.50	2.38	2.88	1.44	3/8-16 UNC	0.69	3.77	5.00	2.50	5.14	2.66	2.44	1.125	1/4 X 1.44
826	4.84	7.12	8.00	2.94	2.63	3.38	1.69	3/8-16 UNC	0.69	4.34	6.38	3.19	5.63	2.73	2.52	1.125	1/4 X 1.44
830	5.25	8.12	8.88	3.25	3.00	4.00	2.00	7/16-14 UNC	0.88	4.84	7.00	3.50	6.75	3.60	3.36	1.250	1/4 X 1.56
832	5.75	8.50	9.38	3.50	3.25	4.00	2.00	7/16-14 UNC	0.88	5.02	7.50	3.75	7.06	3.66	3.42	1.375	5/16 X 2.50
842	6.13	10.25	11.38	4.44	4.25	5.00	2.50	5/8-11 UNC	1.00	6.10	8.50	4.25	8.12	4.50	4.21	1.875	1/2 X 2.50
852	7.19	13.00	14.00	5.12	5.25	5.81	2.91	5/8-11 UNC	1.25	7.50	11.00	5.50	9.06	4.78	4.53	2.000	1/2 X 2.50
860**	8.13	14.25	16.50	6.50	6.00	6.38	3.19	5/8-11 UNC	1.00	N/A	12.75	6.38	10.00	4.65	4.65	2.500	5/8 X 4.00

STYLE BM

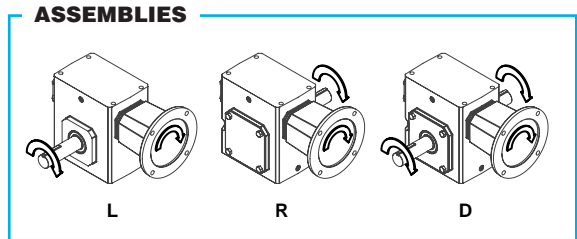
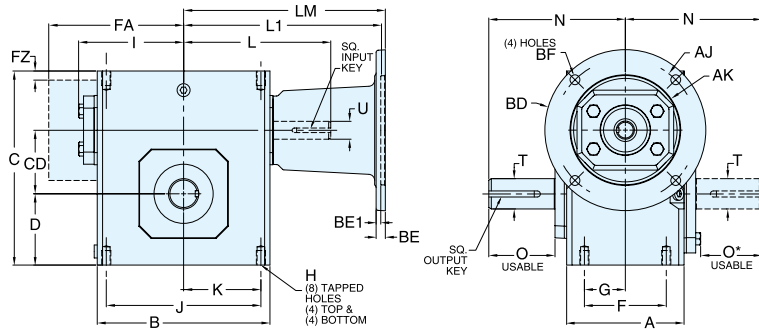

REVERSE ALL ARROWS FOR OPPOSITE INPUT SHAFT ROTATION. CONTACT FACTORY FOR OTHER MOUNTINGS OR ASSEMBLY POSITIONS.

STYLE BM DIMENSIONS (Inches)

Series	A	B	C	D	CD	F	G	H		I	J	K	L	N	O	O*	T +0.000 -0.0015	U +0.000 -0.0015	Input Key	Output Key
								Tap Size	Depth											
813	2.82	3.80	4.66	1.72	1.33	2.00	1.00	5/16-18 UNC	0.50	2.61	3.25	1.63	3.82	4.00	2.16	1.94	0.625	0.500	1/8 X 1.00	3/16 X 1.38
815	3.44	4.88	5.38	1.91	1.54	2.75	1.38	5/16-18 UNC	0.63	3.14	4.19	2.09	4.35	4.31	2.11	1.90	0.750	0.625	3/16 X 1.38	3/16 X 1.38
818	3.56	5.06	5.75	2.06	1.75	2.75	1.38	5/16-18 UNC	0.63	3.24	4.19	2.09	4.45	4.31	2.05	1.84	0.875	0.625	3/16 X 1.38	3/16 X 1.38
821	3.81	5.80	6.38	2.28	2.06	2.88	1.44	3/8-16 UNC	0.63	3.61	5.00	2.50	4.82	4.68	2.29	2.08	1.000	0.625	3/16 X 1.38	1/4 X 1.44
824	4.06	6.12	6.94	2.50	2.38	2.88	1.44	3/8-16 UNC	0.69	3.77	5.00	2.50	5.51	5.14	2.66	2.44	1.125	0.750	3/16 X 1.63	1/4 X 1.44
826	4.84	7.12	8.00	2.94	2.63	3.38	1.69	3/8-16 UNC	0.69	4.34	6.38	3.19	6.07	5.63	2.73	2.52	1.125	0.750	3/16 X 1.63	1/4 X 1.44
830	5.25	8.12	8.88	3.25	3.00	4.00	2.00	7/16-14 UNC	0.88	4.84	7.00	3.50	6.57	6.75	3.60	3.36	1.250	0.875	3/16 X 1.63	1/4 X 1.56
832	5.75	8.50	9.38	3.50	3.25	4.00	2.00	7/16-14 UNC	0.88	5.02	7.50	3.75	6.76	7.06	3.66	3.42	1.375	0.875	3/16 X 1.63	5/16 X 2.50
842	6.13	10.25	11.38	4.44	4.25	5.00	2.50	5/8-11 UNC	1.00	6.10	8.50	4.25	9.57	8.12	4.50	4.21	1.875	1.250	1/4 X 2.50	1/2 X 2.50
852	7.19	13.00	14.00	5.12	5.25	5.81	2.91	5/8-11 UNC	1.25	7.50	11.00	5.50	10.88	9.06	4.78	4.53	2.000	1.250	1/4 X 3.00	1/2 X 2.50
860**	8.13	14.25	16.50	6.50	6.00	6.38	3.19	5/8-11 UNC	1.00	N/A	12.75	6.38	11.78	10.00	4.65	4.65	2.500	1.500	3/8 X 3.00	5/8 X 4.00

STYLE B

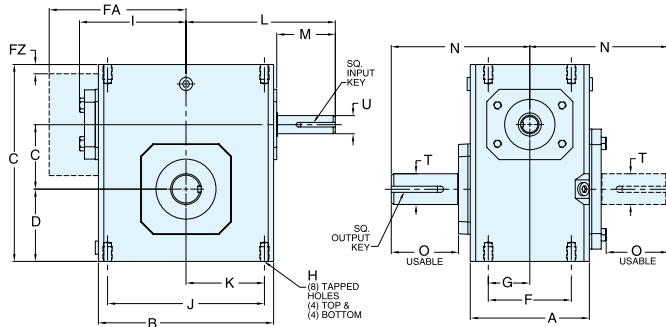

ASSEMBLIES

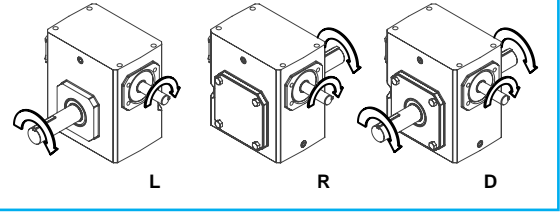

REVERSE ALL ARROWS FOR OPPOSITE INPUT SHAFT ROTATION. CONTACT FACTORY FOR OTHER MOUNTINGS OR ASSEMBLY POSITIONS.

STYLE B DIMENSIONS (Inches)

Series	A	B	C	D	CD	F	G	H		I	J	K	L	M	N	O	O*	T +0.000 -0.0015	U +0.000 -0.0015	Input Key	Output Key
								Tap Size	Depth												
813	2.82	3.80	4.66	1.72	1.33	2.00	1.00	5/16-18 UNC	0.50	2.61	3.25	1.63	3.82	1.76	4.00	2.16	1.94	0.625	0.500	1/8 X 1.00	3/16 X 1.38
815	3.44	4.88	5.38	1.91	1.54	2.75	1.38	5/16-18 UNC	0.63	3.14	4.19	2.09	4.35	1.76	4.31	2.11	1.90	0.750	0.625	3/16 X 1.38	3/16 X 1.38
818	3.56	5.06	5.75	2.06	1.75	2.75	1.38	5/16-18 UNC	0.63	3.24	4.19	2.09	4.45	1.76	4.31	2.05	1.84	0.875	0.625	3/16 X 1.38	3/16 X 1.38
821	3.81	5.80	6.38	2.28	2.06	2.88	1.44	3/8-16 UNC	0.63	3.61	5.00	2.50	4.82	1.76	4.68	2.29	2.08	1.000	0.625	3/16 X 1.38	1/4 X 1.44
824	4.06	6.12	6.94	2.50	2.38	2.88	1.44	3/8-16 UNC	0.69	3.77	5.00	2.50	5.51	2.38	5.14	2.66	2.44	1.125	0.750	3/16 X 1.63	1/4 X 1.44
826	4.84	7.12	8.00	2.94	2.63	3.38	1.69	3/8-16 UNC	0.69	4.34	6.38	3.19	6.07	2.38	5.63	2.73	2.52	1.125	0.750	3/16 X 1.63	1/4 X 1.44
830	5.25	8.12	8.88	3.25	3.00	4.00	2.00	7/16-14 UNC	0.88	4.84	7.00	3.50	6.57	2.38	6.75	3.60	3.36	1.250	0.875	3/16 X 1.63	1/4 X 1.56
832	5.75	8.50	9.38	3.50	3.25	4.00	2.00	7/16-14 UNC	0.88	5.02	7.50	3.75	6.76	2.38	7.06	3.66	3.42	1.375	0.875	3/16 X 1.63	5/16 X 2.50
842	6.13	10.25	11.38	4.44	4.25	5.00	2.50	5/8-11 UNC	1.00	6.10	8.50	4.25	9.57	3.47	8.12	4.50	4.21	1.875	1.250	1/4 X 2.50	1/2 X 2.50
852	7.19	13.00	14.00	5.12	5.25	5.81	2.91	5/8-11 UNC	1.25	7.50	11.00	5.50	10.88	3.38	9.06	4.78	4.53	2.000	1.250	1/4 X 3.00	1/2 X 2.50
860**	8.13	14.25	16.50	6.50	6.00	6.38	3.19	5/8-11 UNC	1.00	N/A	12.75	6.38	11.78	3.41	10.00	4.65	4.65	2.500	1.500	3/8 X 3.00	5/8 X 4.00

MOTOR MOUNTING DIMENSIONS

NEMA DIMENSIONS (Inches)

Series	LM		L1		LQ		LQ1			RQ		
	48CZ	56C/140TC	180TC/210TC	250TC	48CZ/56C/140TC	180TC	210TC	250TC	48CZ/56C/140TC	180TC	210TC	250TC
813	5.63	6.07	N/A	N/A	3.46	N/A	N/A	N/A	3.09	N/A	N/A	N/A
815	6.16	6.60	N/A	N/A	3.99	N/A	N/A	N/A	3.62	N/A	N/A	N/A
818	6.26	6.70	N/A	N/A	4.09	N/A	N/A	N/A	3.59	N/A	N/A	N/A
821	6.63	7.07	N/A	N/A	4.46	N/A	N/A	N/A	4.06	N/A	N/A	N/A
824	N/A	7.76	8.76	N/A	4.63♦	5.06	N/A	N/A	4.09♦	4.56	N/A	N/A
826	N/A	8.32	9.32	N/A	5.19♦	5.62	N/A	N/A	4.82♦	5.13	N/A	N/A
830	N/A	8.82	9.82	N/A	5.69♦	6.12	6.56	N/A	5.32♦	5.63	6.06	N/A
832	N/A	9.01	10.01	N/A	5.88♦	6.31	6.75	N/A	5.51♦	5.81	6.25	N/A
842	N/A	11.81	12.90	13.46	6.45♦	7.21	7.21	7.77	6.04♦	6.68	6.68	7.24
852	N/A	13.21	14.30	14.86	7.85♦	8.61	8.61	9.17	7.35♦	7.98	7.98	8.54
860	N/A	N/A	15.88	16.50	10.45♦	9.33	9.33	9.94	10.01♦	8.69	8.69	8.69

Frame	AJ*	AK	BD	BE	BE1	Bore Dia.	Keyway▲	BF*
48CZ	3.75	3.00	4.36	0.38	N/A	0.500	1/8 X 1/16	0.28
56C	5.88	4.50	6.50	0.38	N/A	0.625	3/16 X 3/32	0.41
140TC	5.88	4.50	6.50	0.38	N/A	0.875	3/16 X 3/32	0.41
180TC	7.25	8.50	8.50	N/A	0.50	1.125	1/4 X 1/8	0.53
210TC	7.25	8.50	8.50	N/A	0.50	1.375	5/16 X 5/32	0.53
250TC	7.25	8.50	8.50	N/A	0.50	1.625	3/8 X 3/16	0.53

IEC DIMENSIONS (Inches)♦

Series	LQ1						RQ					
	D63D	D71D	D80D	D90D	D100LD■	D132D	D63D	D71D	D80D	D90D	D100LD■	D132D
813	2.62	2.65	2.89	N/A	N/A	N/A	2.45	2.47	2.71	N/A	N/A	N/A
815	3.15	3.18	3.42	N/A	N/A	N/A	2.98	3.00	3.24	N/A	N/A	N/A
818	3.25	3.28	3.52	N/A	N/A	N/A	2.95	2.97	3.21	N/A	N/A	N/A
821	3.62	3.65	3.89	N/A	N/A	N/A	3.43	3.44	3.68	N/A	N/A	N/A
824	N/A	3.72	4.34	N/A	N/A	N/A	3.46	3.46	3.71	N/A	N/A	N/A
826	N/A	4.28	4.90	4.90	5.30	N/A	4.09	4.72	4.72	5.07	N/A	N/A
830	N/A	4.78	5.41	5.41	5.80	N/A	4.59	5.22	5.22	5.57	N/A	N/A
832	N/A	4.97	5.59	5.59	5.99	N/A	4.78	5.41	5.41	5.76	N/A	N/A
842	N/A	N/A	N/A	6.38	6.39	7.17	N/A	N/A	N/A	6.16	6.14	6.93
852	N/A	N/A	N/A	7.78	7.78	8.57	N/A	N/A	N/A	7.46	7.45	8.24

Frame●	AJ	AK	BD	BE	Bore Dia.	Keyway▲	BF TAP	OD
D63D	115	95	117	10	11	4 X 2	M8 X 1.25	131
D71D	130	110	132	11	14	5 X 2.5	M8 X 1.25	146
D80D	165	130	165	15	19	6 X 3	M10 X 1.50	184
D90D	165	130	165	15	24	8 X 3.5	M10 X 1.50	184
D100LD■	215	180	216	18	28	8 X 3.5	M12 X 1.75	237
D132D	265	230	267	18	38	10 X 4	M12 X 1.75	290

- * Applies to double output shaft
- ** Series 860 reducers are supplied with a fan. Dimension FA=11.13" and dimension FZ=.33"
- ▲ Keyway width by depth
- ♦ Mounting holes rotated 45° from positions shown on series BM860 with frame sizes 180TC - 250TC.
- ♦ Metric input flange options are available on quill input styles only.
- ♦ 48CZ not available
- Also applies to frame size D112MD
- Dimensions in millimeters (mm).

STYLE TMQ

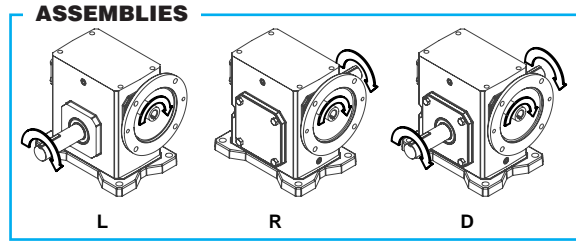
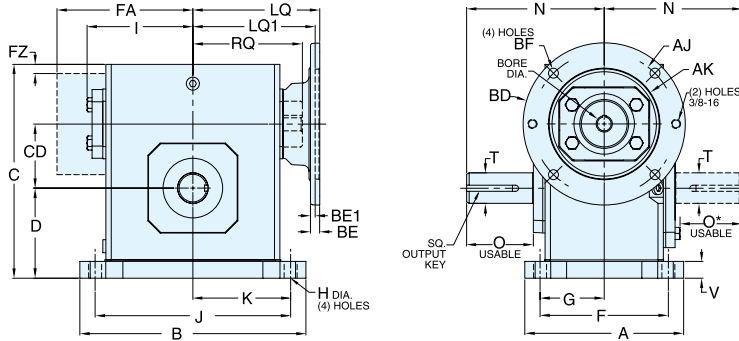

REVERSE ALL ARROWS FOR OPPOSITE INPUT SHAFT ROTATION. CONTACT FACTORY FOR OTHER MOUNTINGS OR ASSEMBLY POSITIONS.

STYLE TMQ DIMENSIONS (Inches)

Series	A	B	C	D	CD	F	G	H	I	J	K	N	O	O*	T +0.000 -0.0015	V	Output Key
813	4.24	5.37	5.19	2.25	1.33	3.31	1.66	0.34	2.61	4.37	2.19	4.00	2.16	1.94	0.625	0.53	3/16 X 1.38
815	5.56	6.50	5.97	2.50	1.54	4.31	2.16	0.41	3.14	5.25	2.63	4.31	2.11	1.90	0.750	0.59	3/16 X 1.38
818	5.75	6.99	6.44	2.75	1.75	4.50	2.25	0.41	3.24	5.75	2.88	4.31	2.05	1.84	0.875	0.69	3/16 X 1.38
821	6.00	7.69	7.09	3.00	2.06	4.69	2.34	0.47	3.61	6.38	3.19	4.68	2.29	2.08	1.000	0.72	1/4 X 1.44
824	6.19	8.37	7.69	3.25	2.38	4.88	2.44	0.49	3.77	7.06	3.53	5.14	2.66	2.44	1.125	0.75	1/4 X 1.44
826	6.50	9.25	8.75	3.69	2.63	5.25	2.63	0.53	4.34	8.00	4.00	5.63	2.73	2.52	1.125	0.75	1/4 X 1.44
830	7.50	10.00	9.63	4.00	3.00	5.88	2.94	0.53	4.84	8.44	4.22	6.75	3.60	3.36	1.250	0.75	1/4 X 1.56
832	7.75	11.12	10.25	4.38	3.25	6.13	3.06	0.53	5.02	9.50	4.75	7.06	3.66	3.42	1.375	0.81	5/16 X 2.50
842	9.75	13.24	12.38	5.44	4.25	7.63	3.81	0.66	6.10	11.12	5.56	8.12	4.50	4.21	1.875	1.00	1/2 X 2.50
852	10.50	16.24	15.13	6.25	5.25	8.38	4.19	0.78	7.50	14.12	7.06	9.06	4.78	4.53	2.000	1.13	1/2 X 2.50
860**	12.00	18.99	17.75	7.75	6.00	9.50	4.75	0.91	N/A	16.49	8.25	10.00	4.65	4.65	2.500	1.25	5/8 X 4.00

STYLE TM

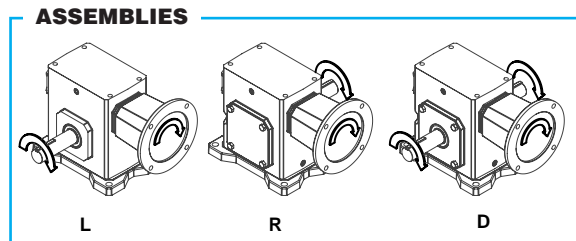
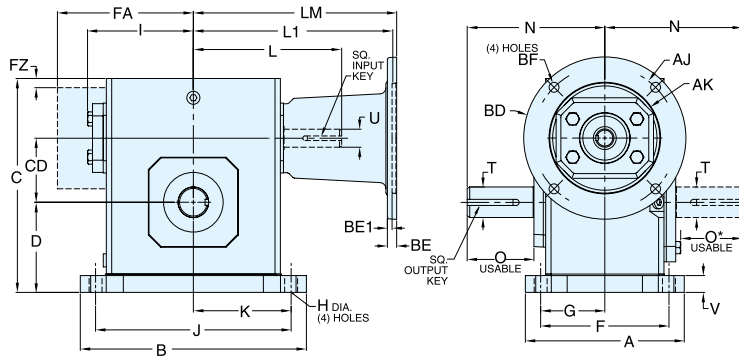

REVERSE ALL ARROWS FOR OPPOSITE INPUT SHAFT ROTATION. CONTACT FACTORY FOR OTHER MOUNTINGS OR ASSEMBLY POSITIONS.

STYLE TM DIMENSIONS (Inches)

Series	A	B	C	D	CD	F	G	H	I	J	K	L	N	O	O*	T +0.000 -0.0015	U +0.000 -0.0015	V	Input Key	Output Key
813	4.24	5.37	5.19	2.25	1.33	3.31	1.66	0.34	2.61	4.37	2.19	3.82	4.00	2.16	1.94	0.625	0.500	0.53	1/8 X 1.00	3/16 X 1.38
815	5.56	6.50	5.97	2.50	1.54	4.31	2.16	0.41	3.14	5.25	2.63	4.35	4.31	2.11	1.90	0.750	0.625	0.59	3/16 X 1.38	3/16 X 1.38
818	5.75	6.99	6.44	2.75	1.75	4.50	2.25	0.41	3.24	5.75	2.88	4.45	4.31	2.05	1.84	0.875	0.625	0.69	3/16 X 1.38	3/16 X 1.38
821	6.00	7.69	7.09	3.00	2.06	4.69	2.34	0.47	3.61	6.38	3.19	4.82	4.68	2.29	2.08	1.000	0.625	0.72	3/16 X 1.38	1/4 X 1.44
824	6.19	8.37	7.69	3.25	2.38	4.88	2.44	0.49	3.77	7.06	3.53	5.51	5.14	2.66	2.44	1.125	0.750	0.75	3/16 X 1.63	1/4 X 1.44
826	6.50	9.25	8.75	3.69	2.63	5.25	2.63	0.53	4.34	8.00	4.00	6.07	5.63	2.73	2.52	1.125	0.750	0.75	3/16 X 1.63	1/4 X 1.44
830	7.50	10.00	9.63	4.00	3.00	5.88	2.94	0.53	4.84	8.44	4.22	6.57	6.75	3.60	3.36	1.250	0.875	0.75	3/16 X 1.63	1/4 X 1.56
832	7.75	11.12	10.25	4.38	3.25	6.13	3.06	0.53	5.02	9.50	4.75	6.76	7.06	3.66	3.42	1.375	0.875	0.81	3/16 X 1.63	5/16 X 2.50
842	9.75	13.24	12.38	5.44	4.25	7.63	3.81	0.66	6.10	11.12	5.56	9.57	8.12	4.50	4.21	1.875	1.250	1.00	1/4 X 2.50	1/2 X 2.50
852	10.50	16.24	15.13	6.25	5.25	8.38	4.19	0.78	7.50	14.12	7.06	10.88	9.06	4.78	4.53	2.000	1.250	1.13	1/4 X 3.00	1/2 X 2.50
860**	12.00	18.99	17.75	7.75	6.00	9.50	4.75	0.91	N/A	16.49	8.25	11.78	10.00	4.65	4.65	2.500	1.500	1.25	3/8 X 3.00	5/8 X 4.00

STYLE T

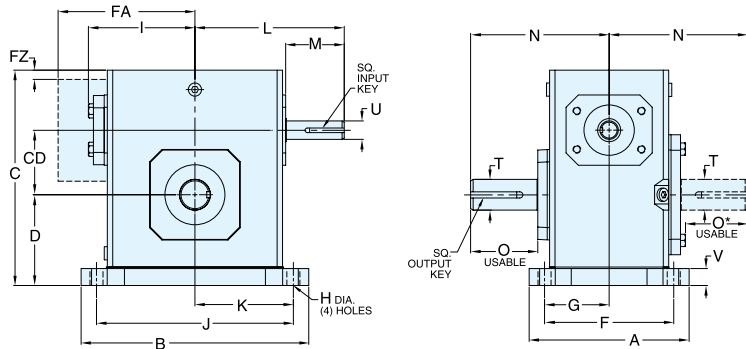

ASSEMBLIES

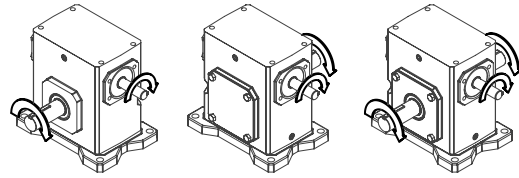

REVERSE ALL ARROWS FOR OPPOSITE INPUT SHAFT ROTATION. CONTACT FACTORY FOR OTHER MOUNTINGS OR ASSEMBLY POSITIONS.

STYLE T DIMENSIONS (Inches)

Series	A	B	C	D	CD	F	G	H	I	J	K	L	M	N	O	O*	T +0.000 -0.0015	U +0.000 -0.0015	V	Input Key	Output Key
813	4.24	5.37	5.19	2.25	1.33	3.31	1.66	0.34	2.61	4.37	2.19	3.82	1.76	4.00	2.16	1.94	0.625	0.500	0.53	1/8 X 1.00	3/16 X 1.38
815	5.56	6.50	5.97	2.50	1.54	4.31	2.16	0.41	3.14	5.25	2.63	4.35	1.76	4.31	2.11	1.90	0.750	0.625	0.59	3/16 X 1.38	3/16 X 1.38
818	5.75	6.99	6.44	2.75	1.75	4.50	2.25	0.41	3.24	5.75	2.88	4.45	1.76	4.31	2.05	1.84	0.875	0.625	0.69	3/16 X 1.38	3/16 X 1.38
821	6.00	7.69	7.09	3.00	2.06	4.69	2.34	0.47	3.61	6.38	3.19	4.82	1.76	4.68	2.29	2.08	1.000	0.625	0.72	3/16 X 1.38	1/4 X 1.44
824	6.19	8.37	7.69	3.25	2.38	4.88	2.44	0.49	3.77	7.06	3.53	5.51	2.38	5.14	2.66	2.44	1.125	0.750	0.75	3/16 X 1.63	1/4 X 1.44
826	6.50	9.25	8.75	3.69	2.63	5.25	2.63	0.53	4.34	8.00	4.00	6.07	2.38	5.63	2.73	2.52	1.125	0.750	0.75	3/16 X 1.63	1/4 X 1.44
830	7.50	10.00	9.63	4.00	3.00	5.88	2.94	0.53	4.84	8.44	4.22	6.57	2.38	6.75	3.60	3.36	1.250	0.875	0.75	3/16 X 1.63	1/4 X 1.56
832	7.75	11.12	10.25	4.38	3.25	6.13	3.06	0.53	5.02	9.50	4.75	6.76	2.38	7.06	3.66	3.42	1.375	0.875	0.81	3/16 X 1.63	5/16 X 2.50
842	9.75	13.24	12.38	5.44	4.25	7.63	3.81	0.66	6.10	11.12	5.56	9.57	3.47	8.12	4.50	4.21	1.875	1.250	1.00	1/4 X 2.50	1/2 X 2.50
852	10.50	16.24	15.13	6.25	5.25	8.38	4.19	0.78	7.50	14.12	7.06	10.88	3.38	9.06	4.78	4.53	2.000	1.250	1.13	1/4 X 3.00	1/2 X 2.50
860**	12.00	18.99	17.75	7.75	6.00	9.50	4.75	0.91	N/A	16.49	8.25	11.78	3.41	10.00	4.65	4.65	2.500	1.500	1.25	3/8 X 3.00	5/8 X 4.00

MOTOR MOUNTING DIMENSIONS

NEMA DIMENSIONS (Inches)

Series	LM		L1		LQ		LQ1			RQ		
	48CZ	56C/140TC	180TC/210TC	250TC	48CZ/56C/140TC	180TC	210TC	250TC	48CZ/56C/140TC	180TC	210TC	250TC
813	5.63	6.07	N/A	N/A	3.46	N/A	N/A	N/A	3.09	N/A	N/A	N/A
815	6.16	6.60	N/A	N/A	3.99	N/A	N/A	N/A	3.62	N/A	N/A	N/A
818	6.26	6.70	N/A	N/A	4.09	N/A	N/A	N/A	3.59	N/A	N/A	N/A
821	6.63	7.07	N/A	N/A	4.46	N/A	N/A	N/A	4.06	N/A	N/A	N/A
824	N/A	7.76	8.76	N/A	4.63♦	5.06	N/A	N/A	4.09♦	4.56	N/A	N/A
826	N/A	8.32	9.32	N/A	5.19♦	5.62	N/A	N/A	4.82♦	5.13	N/A	N/A
830	N/A	8.82	9.82	N/A	5.69♦	6.12	6.56	N/A	5.32♦	5.63	6.06	N/A
832	N/A	9.01	10.01	N/A	5.88♦	6.31	6.75	N/A	5.51♦	5.81	6.25	N/A
842	N/A	11.81	12.90	13.46	6.45♦	7.21	7.21	7.77	6.04♦	6.68	6.68	7.24
852	N/A	13.21	14.30	14.86	7.85♦	8.61	8.61	9.17	7.35♦	7.98	7.98	8.54
860	N/A	N/A	15.88	16.50	10.45♦	9.33	9.33	9.94	10.01♦	8.69	8.69	8.69

Frame	AJ*	AK	BD	BE	BE1	Bore Dia.	Keyway▲	BF*
48CZ	3.75	3.00	4.36	0.38	N/A	0.500	1/8 X 1/16	0.28
56C	5.88	4.50	6.50	0.38	N/A	0.625	3/16 X 3/32	0.41
140TC	5.88	4.50	6.50	0.38	N/A	0.875	3/16 X 3/32	0.41
180TC	7.25	8.50	8.50	N/A	0.50	1.125	1/4 X 1/8	0.53
210TC	7.25	8.50	8.50	N/A	0.50	1.375	5/16 X 5/32	0.53
250TC	7.25	8.50	8.50	N/A	0.50	1.625	3/8 X 3/16	0.53

IEC DIMENSIONS (Inches)♦

Series	LQ1						RQ					
	D63D	D71D	D80D	D90D	D100LD■	D132D	D63D	D71D	D80D	D90D	D100LD■	D132D
813	2.62	2.65	2.89	N/A	N/A	N/A	2.45	2.47	2.71	N/A	N/A	N/A
815	3.15	3.18	3.42	N/A	N/A	N/A	2.98	3.00	3.24	N/A	N/A	N/A
818	3.25	3.28	3.52	N/A	N/A	N/A	2.95	2.97	3.21	N/A	N/A	N/A
821	3.62	3.65	3.89	N/A	N/A	N/A	3.43	3.44	3.68	N/A	N/A	N/A
824	N/A	3.72	4.34	N/A	N/A	N/A	N/A	3.46	3.71	N/A	N/A	N/A
826	N/A	4.28	4.90	4.90	5.30	N/A	N/A	4.09	4.72	4.72	5.07	N/A
830	N/A	4.78	5.41	5.41	5.80	N/A	N/A	4.59	5.22	5.22	5.57	N/A
832	N/A	4.97	5.59	5.59	5.99	N/A	N/A	4.78	5.41	5.41	5.76	N/A
842	N/A	N/A	N/A	6.38	6.39	7.17	N/A	N/A	N/A	6.16	6.14	6.93
852	N/A	N/A	N/A	7.78	7.78	8.57	N/A	N/A	N/A	7.46	7.45	8.24

Frame●	AJ	AK	BD	BE	Bore Dia.	Keyway▲	BF TAP	OD
D63D	115	95	117	10	11	4 X 2	M8 X 1.25	131
D71D	130	110	132	11	14	5 X 2.5	M8 X 1.25	146
D80D	165	130	165	15	19	6 X 3	M10 X 1.50	184
D90D	165	130	165	15	24	8 X 3.5	M10 X 1.50	184
D100LD■	215	180	216	18	28	8 X 3.5	M12 X 1.75	237
D132D	265	230	267	18	38	10 X 4	M12 X 1.75	290

- * Applies to double output shaft
- ** Series 860 reducers are supplied with a fan. Dimension FA=11.13" and dimension FZ=.33"
- ▲ Keyway width by depth
- * Mounting holes rotated 45° from positions shown on series BM860 with frame sizes 180TC - 250TC.
- ♦ Metric input flange options are available on quill input styles only.
- ◆ 48CZ not available
- Also applies to frame size D112MD
- Dimensions in millimeters (mm).

STYLE HMQ

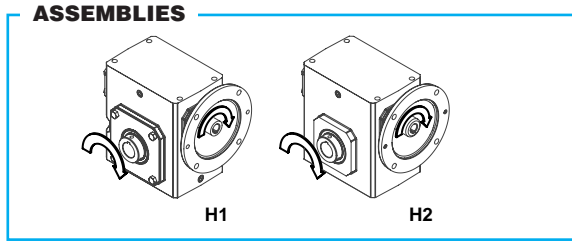
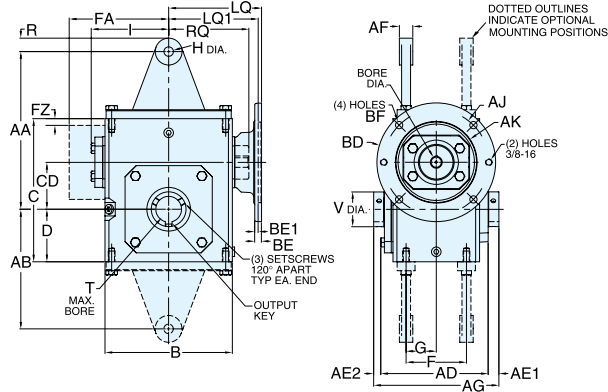

REVERSE ALL ARROWS FOR OPPOSITE INPUT SHAFT ROTATION. CONTACT FACTORY FOR OTHER MOUNTINGS OR ASSEMBLY POSITIONS.

STYLE HMQ DIMENSIONS (Inches)

Series	AA	AB	AD	AE1	AE2	AF	AG	B	C	D	CD	F	G	H	I	R	T MAX -0.000 +0.0025	V	Output Key
813	4.19	2.97	3.90	0.53	0.32	0.75	4.75	3.80	4.66	1.72	1.33	2.00	1.00	0.53	2.61	0.50	0.625	1.00	3/16 X 1.50
815	5.97	4.41	4.61	0.51	0.30	0.75	5.42	5.19	5.38	1.91	1.54	2.75	1.38	0.53	3.14	0.75	0.625	1.00	3/16 X 1.50
818	6.19	4.56	4.73	0.49	0.28	0.75	5.50	5.19	5.75	2.06	1.75	2.75	1.38	0.53	3.24	0.75	1.000	1.44	1/4 X 3.00
821	7.24	5.43	4.99	0.61	0.40	0.75	6.00	5.80	6.38	2.28	2.06	2.88	1.44	0.53	3.61	0.75	1.438	1.94	3/8 X 3.00
824	7.69	5.75	5.18	0.51	0.31	0.75	6.00	6.12	6.94	2.50	2.38	2.88	1.44	0.69	3.77	0.75	1.438	1.94	3/8 X 3.00
826	8.81	6.69	6.01	0.60	0.39	0.75	7.00	7.38	8.00	2.94	2.63	3.38	1.69	0.53	4.34	0.75	1.438	1.94	3/8 X 3.00
830	10.63	8.25	6.53	0.60	0.36	0.75	7.50	8.12	8.88	3.25	3.00	4.00	2.00	0.53	4.84	0.88	1.938	2.51	1/2 X 3.00
832	10.88	8.50	7.04	0.54	0.29	0.75	7.88	8.75	9.38	3.50	3.25	4.00	2.00	0.53	5.02	0.88	1.938	2.51	1/2 X 3.00
842	11.94	9.44	7.53	0.63	0.34	0.75	8.50	10.25	11.38	4.44	4.25	5.00	2.50	0.53	6.10	0.75	2.188	2.75	1/2 X 3.00
852	13.88	10.12	8.85	0.97	0.68	1.00	10.50	13.00	14.00	5.12	5.25	5.81	2.91	0.66	7.50	1.00	3.438	4.26	7/8 X 3.44
860**	15.00	11.50	10.52	0.52	0.52	0.38	11.50	14.50	16.50	6.50	6.00	6.38	3.19	0.66	N/A	0.69	3.438	4.18	7/8 X 3.44

STYLE HM

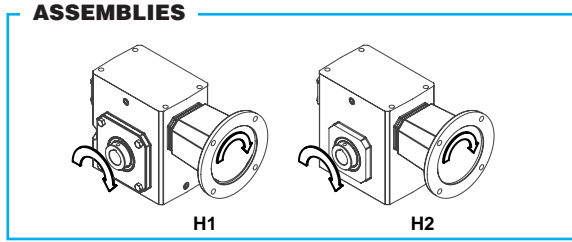
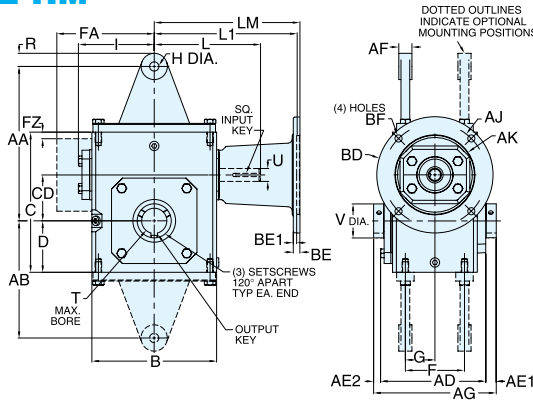

REVERSE ALL ARROWS FOR OPPOSITE INPUT SHAFT ROTATION. CONTACT FACTORY FOR OTHER MOUNTINGS OR ASSEMBLY POSITIONS.

STYLE HM DIMENSIONS (Inches)

Series	AA	AB	AD	AE1	AE2	AF	AG	B	C	D	CD	F	G	H	I	L	R	T MAX -0.000 +0.0025	U +0.000 -0.0015	V	Input Key	Output Ket
813	4.19	2.97	3.90	0.53	0.32	0.75	4.75	3.80	4.66	1.72	1.33	2.00	1.00	0.53	2.61	3.82	0.50	0.625	0.500	1.00	1/8 X 1.00	3/16 X 1.50
815	5.97	4.41	4.61	0.51	0.30	0.75	5.42	5.19	5.38	1.91	1.54	2.75	1.38	0.53	3.14	4.35	0.75	0.625	0.625	1.00	3/16 X 1.38	3/16 X 1.50
818	6.19	4.56	4.73	0.49	0.28	0.75	5.50	5.19	5.75	2.06	1.75	2.75	1.38	0.53	3.24	4.45	0.75	1.000	0.625	1.44	3/16 X 1.38	1/4 X 3.00
821	7.24	5.43	4.99	0.61	0.40	0.75	6.00	5.80	6.38	2.28	2.06	2.88	1.44	0.53	3.61	4.82	0.75	1.438	0.625	1.94	3/16 X 1.38	3/8 X 3.00
824	7.69	5.75	5.18	0.51	0.31	0.75	6.00	6.12	6.94	2.50	2.38	2.88	1.44	0.69	3.77	5.51	0.75	1.438	0.750	1.94	3/16 X 1.63	3/8 X 3.00
826	8.81	6.69	6.01	0.60	0.39	0.75	7.00	7.38	8.00	2.94	2.63	3.38	1.69	0.53	4.34	6.07	0.75	1.438	0.750	1.94	3/16 X 1.63	3/8 X 3.00
830	10.63	8.25	6.53	0.60	0.36	0.75	7.50	8.12	8.88	3.25	3.00	4.00	2.00	0.53	4.84	6.57	0.88	1.938	0.875	2.51	3/16 X 1.63	1/2 X 3.00
832	10.88	8.50	7.04	0.54	0.29	0.75	7.88	8.75	9.38	3.50	3.25	4.00	2.00	0.53	5.02	6.76	0.88	1.938	0.875	2.51	3/16 X 1.63	1/2 X 3.00
842	11.94	9.44	7.53	0.63	0.34	0.75	8.50	10.25	11.38	4.44	4.25	5.00	2.50	0.53	6.10	9.57	0.75	2.188	1.250	2.75	1/4 X 2.50	1/2 X 3.00
852	13.88	10.12	8.85	0.97	0.68	1.00	10.50	13.00	14.00	5.12	5.25	5.81	2.91	0.66	7.50	10.88	1.00	3.438	1.250	4.26	1/4 X 3.00	7/8 X 3.44
860**	15.00	11.50	10.52	0.52	0.52	0.38	11.50	14.50	16.50	6.50	6.00	6.38	3.19	0.66	N/A	11.78	0.69	3.438	1.500	4.18	3/8 X 3.00	7/8 X 3.44

STYLE H

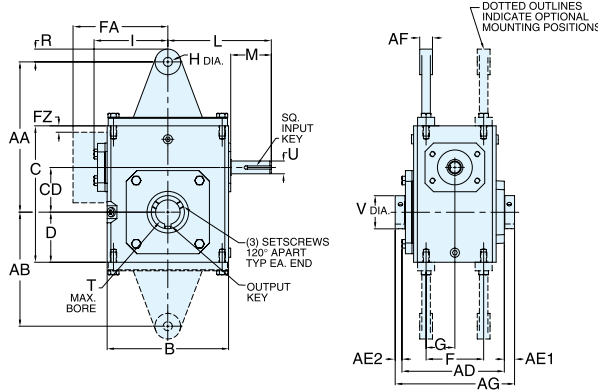

ASSEMBLIES

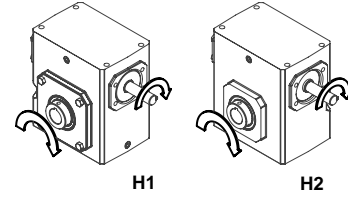

REVERSE ALL ARROWS FOR OPPOSITE INPUT SHAFT ROTATION. CONTACT FACTORY FOR OTHER MOUNTINGS OR ASSEMBLY POSITIONS.

STYLE H DIMENSIONS (Inches)

Series	AA	AB	AD	AE1	AE2	AF	AG	B	C	D	CD	F	G	H	I	L	M	R	T MAX▼ -0.000 +0.0025	U +0.000 -0.0015	V	Input Key	Output Ket
813	4.19	2.97	3.90	0.53	0.32	0.75	4.75	3.80	4.66	1.72	1.33	2.00	1.00	0.53	2.61	3.82	1.76	0.50	0.625	0.500	1.00	1/8 X 1.00	3/16 X 1.50
815	5.97	4.41	4.61	0.51	0.30	0.75	5.42	5.19	5.38	1.91	1.54	2.75	1.38	0.53	3.14	4.35	1.76	0.75	0.625	0.625	1.00	3/16 X 1.38	3/16 X 1.50
818	6.19	4.56	4.73	0.49	0.28	0.75	5.50	5.19	5.75	2.06	1.75	2.75	1.38	0.53	3.24	4.45	1.76	0.75	1.000	0.625	1.44	3/16 X 1.38	1/4 X 3.00
821	7.24	5.43	4.99	0.61	0.40	0.75	6.00	5.80	6.38	2.28	2.06	2.88	1.44	0.53	3.61	4.82	1.76	0.75	1.438	0.625	1.94	3/16 X 1.38	3/8 X 3.00
824	7.69	5.75	5.18	0.51	0.31	0.75	6.00	6.12	6.94	2.50	2.38	2.88	1.44	0.69	3.77	5.51	2.38	0.75	1.438	0.750	1.94	3/16 X 1.63	3/8 X 3.00
826	8.81	6.69	6.01	0.60	0.39	0.75	7.00	7.38	8.00	2.94	2.63	3.38	1.69	0.53	4.34	6.07	2.38	0.75	1.438	0.750	1.94	3/16 X 1.63	3/8 X 3.00
830	10.63	8.25	6.53	0.60	0.36	0.75	7.50	8.12	8.88	3.25	3.00	4.00	2.00	0.53	4.84	6.57	2.38	0.88	1.938	0.875	2.51	3/16 X 1.63	1/2 X 3.00
832	10.88	8.50	7.04	0.54	0.29	0.75	7.88	8.75	9.38	3.50	3.25	4.00	2.00	0.53	5.02	6.76	2.38	0.88	1.938	0.875	2.51	3/16 X 1.63	1/2 X 3.00
842	11.94	9.44	7.53	0.63	0.34	0.75	8.50	10.25	11.38	4.44	4.25	5.00	2.50	0.53	6.10	9.57	3.47	0.75	2.188	1.250	2.75	1/4 X 2.50	1/2 X 3.00
852	13.88	10.12	8.85	0.97	0.68	1.00	10.50	13.00	14.00	5.12	5.25	5.81	2.91	0.66	7.50	10.88	3.38	1.00	3.438	1.250	4.26	1/4 X 3.00	7/8 X 3.44
860**	15.00	11.50	10.52	0.52	0.52	0.38	11.50	14.50	16.50	6.50	6.00	6.38	3.19	0.66	N/A	11.78	3.41	0.69	3.438	1.500	4.18	3/8 X 3.00	7/8 X 3.44

MOTOR MOUNTING DIMENSIONS

NEMA DIMENSIONS (Inches)

Series	LM		L1		LQ		LQ1			RQ		
	48CZ	56C/140TC	180TC/210TC	250TC	48CZ/56C/140TC	180TC	210TC	250TC	48CZ/56C/140TC	180TC	210TC	250TC
813	5.63	6.07	N/A	N/A	3.46	N/A	N/A	N/A	3.09	N/A	N/A	N/A
815	6.16	6.60	N/A	N/A	3.99	N/A	N/A	N/A	3.62	N/A	N/A	N/A
818	6.26	6.70	N/A	N/A	4.09	N/A	N/A	N/A	3.59	N/A	N/A	N/A
821	6.63	7.07	N/A	N/A	4.46	N/A	N/A	N/A	4.06	N/A	N/A	N/A
824	N/A	7.76	8.76	N/A	4.63♦	5.06	N/A	N/A	4.09♦	4.56	N/A	N/A
826	N/A	8.32	9.32	N/A	5.19♦	5.62	N/A	N/A	4.82♦	5.13	N/A	N/A
830	N/A	8.82	9.82	N/A	5.69♦	6.12	6.56	N/A	5.32♦	5.63	6.06	N/A
832	N/A	9.01	10.01	N/A	5.88♦	6.31	6.75	N/A	5.51♦	5.81	6.25	N/A
842	N/A	11.81	12.90	13.46	6.45♦	7.21	7.21	7.77	6.04♦	6.68	6.68	7.24
852	N/A	13.21	14.30	14.86	7.85♦	8.61	8.61	9.17	7.35♦	7.98	7.98	8.54
860	N/A	N/A	15.88	16.50	10.45♦	9.33	9.33	9.94	10.01♦	8.69	8.69	8.69

Frame	AJ*	AK	BD	BE	BE1	Bore Dia.	Keyway▲	BF*
48CZ	3.75	3.00	4.36	0.38	N/A	0.500	1/8 X 1/16	0.28
56C	5.88	4.50	6.50	0.38	N/A	0.625	3/16 X 3/32	0.41
140TC	5.88	4.50	6.50	0.38	N/A	0.875	3/16 X 3/32	0.41
180TC	7.25	8.50	8.50	N/A	0.50	1.125	1/4 X 1/8	0.53
210TC	7.25	8.50	8.50	N/A	0.50	1.375	5/16 X 5/32	0.53
250TC	7.25	8.50	8.50	N/A	0.50	1.625	3/8 X 3/16	0.53

IEC DIMENSIONS (Inches)♦

Series	LQ1						RQ					
	D63D	D71D	D80D	D90D	D100LD■	D132D	D63D	D71D	D80D	D90D	D100LD■	D132D
813	2.62	2.65	2.89	N/A	N/A	N/A	2.45	2.47	2.71	N/A	N/A	N/A
815	3.15	3.18	3.42	N/A	N/A	N/A	2.98	3.00	3.24	N/A	N/A	N/A
818	3.25	3.28	3.52	N/A	N/A	N/A	2.95	2.97	3.21	N/A	N/A	N/A
821	3.62	3.65	3.89	N/A	N/A	N/A	3.43	3.44	3.68	N/A	N/A	N/A
824	N/A	3.72	4.34	N/A	N/A	N/A	N/A	3.46	3.71	N/A	N/A	N/A
826	N/A	4.28	4.90	4.90	5.30	N/A	N/A	4.09	4.72	4.72	5.07	N/A
830	N/A	4.78	5.41	5.41	5.80	N/A	N/A	4.59	5.22	5.22	5.57	N/A
832	N/A	4.97	5.59	5.59	5.99	N/A	N/A	4.78	5.41	5.41	5.76	N/A
842	N/A	N/A	N/A	6.38	6.39	7.17	N/A	N/A	N/A	6.16	6.14	6.93
852	N/A	N/A	N/A	7.78	7.78	8.57	N/A	N/A	N/A	7.46	7.45	8.24

Frame●	AJ	AK	BD	BE	Bore Dia.	Keyway▲	BF TAP	OD
D63D	115	95	117	10	11	4 X 2	M8 X 1.25	131
D71D	130	110	132	11	14	5 X 2.5	M8 X 1.25	146
D80D	165	130	165	15	19	6 X 3	M10 X 1.50	184
D90D	165	130	165	15	24	8 X 3.5	M10 X 1.50	184
D100LD■	215	180	216	18	28	8 X 3.5	M12 X 1.75	237
D132D	265	230	267	18	38	10 X 4	M12 X 1.75	290

** Series 860 reducers are supplied with a fan. Dimension FA=11.13" and dimension FZ=.33"

- ▲ Keyway width by depth
- * Mounting holes rotated 45° from positions shown on series BM860 with frame sizes 180TC - 250TC.
- ♦ Metric input flange options are available on quill input styles only.
- ◆ 48CZ not available
- Also applies to frame size D112MD
- Dimensions in millimeters (mm).
- ▼ For additional bore sizes available, refer to page 144.