

B3 FOOT-MOUNTED

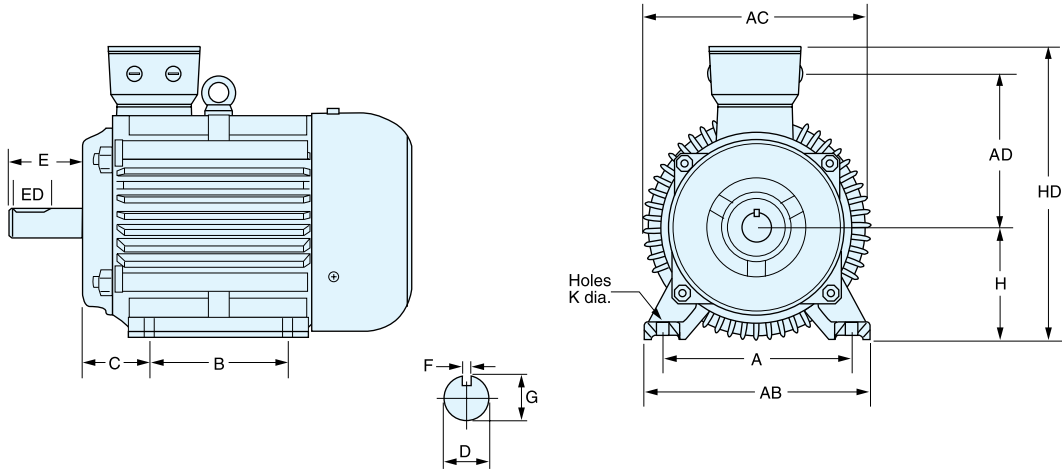

METRIC (IEC) FRAME DIMENSIONS (Millimeters)

Frame	Mounting						Shaft						General			B5 Flange						B14 Face					
	A	B	C	H	AB	K	D	E	F	G	ED	DH	AC	AD	HD	M	N	P	S	T	LA	M	N	P	S	T	LA
D56	90	71	36	56	107	6	9	20	3	7.5	8	M3 x 8	-	-	-	100	80	120	7	2.5	7	65	50	80	M5	2.5	7
D63	100	80	40	63	122	7	11	23	4	8.5	10	M4 x 10	126	84	171	115	95	140	10	3.0	7	75	60	90	M5	2.5	7
D71	112	90	45	71	136	7	14	30	5	11.0	20	M5 x 12.5	141	94	191	130	110	160	10	3.5	7	85	70	105	M6	2.5	9
D80	125	100	50	80	154	10	19	40	6	15.5	25	M6 x 16	159	102	206	165	130	200	12	3.5	12	100	80	120	M6	3.0	9
D90S	140	100	56	90	172	10	24	50	8	20.0	32	M8 x 19	180	112	229	165	130	200	12	3.5	12	115	95	140	M8	3.0	9
D90L	140	125	56	90	172	10	24	50	8	20.0	32	M8 x 19	180	112	229	165	130	200	12	3.5	12	115	95	140	M8	3.0	9
DF100L	160	140	63	100	205	12	28	60	8	24.0	40	M10 x 22	205	130	270	215	180	250	15	4.0	11	130	110	160	M8	3.5	14
DF112M	190	140	70	112	230	12	28	60	8	24.0	40	M10 x 22	240	150	300	215	180	250	15	4.0	12	130	110	160	M8	3.5	11
DF132S	216	140	89	132	270	12	38	80	10	33.0	56	M12 x 28	275	180	345	265	230	300	15	4.0	12	165	130	200	M10	3.5	14
DF132M	216	178	89	132	270	12	38	80	10	33.0	56	M12 x 28	275	180	345	265	230	300	15	4.0	12	165	130	200	M10	3.5	14
DF160M	254	210	108	160	320	15	42	110	12	37.0	80	M16 x 36	330	210	420	300	250	350	19	5.0	13	215	180	250	M12	4.0	13
DF160L	254	254	108	160	320	15	42	110	12	37.0	80	M16 x 36	330	210	420	300	250	350	19	5.0	13	215	180	250	M12	4.0	13
DF180M	279	241	121	180	355	15	48	110	14	42.5	80	M16 x 36	360	236	455	300	250	350	19	5.0	15	-	-	-	-	-	-
DF180L	279	279	121	180	355	15	48	110	14	42.5	80	M16 x 36	360	236	455	300	250	350	19	5.0	15	-	-	-	-	-	-
DF200L	318	305	133	200	395	19	55	110	16	49.0	100	M20 x 42	420	260	505	-	-	-	-	-	-	-	-	-	-	-	-
DF225S	356	286	149	225	435	19	55*	110*	16*	49*	100*	M20 x 42	450	275	580	-	-	-	-	-	-	-	-	-	-	-	-
DF225M	356	311	149	225	435	19	55*	110*	16*	49*	100*	M20 x 42	450	275	580	-	-	-	-	-	-	-	-	-	-	-	-
DF250M	406	349	168	250		24	60*	140*	18*	53*	125*	M20 x 42	508	300	625	-	-	-	-	-	-	-	-	-	-	-	-

* 2 Pole Dimensions

The overall length dimension for each catalog item is listed on pages 68-70 of this catalog. Frames DF100L through DF132M, conduit box is located in the center of the frame.

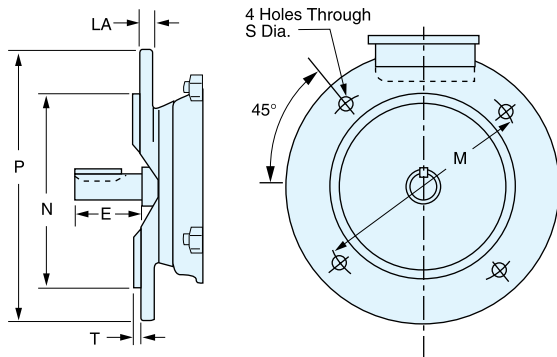

B5 FLANGE

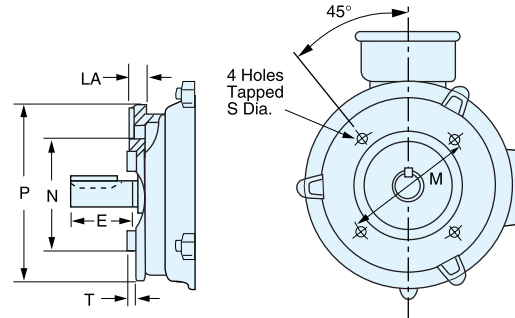

B14 FACE

RIGID MOUNT 158 SERIES

C FACE 158 SERIES

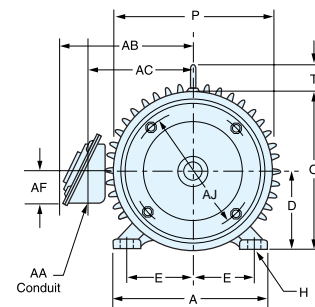
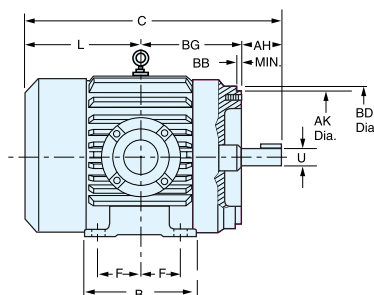
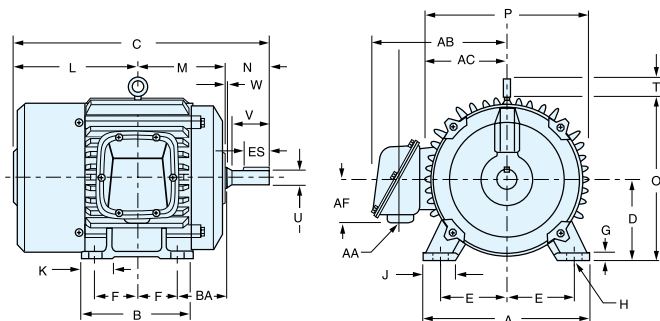

NEMA EXPLOSION-PROOF • 158 SERIES • RIGID MOUNT DIMENSIONS (Inches)

Frame Size	A	B	D	E	F	G	H	J	K	L	M	N	O	P	T	U	V	N-W	ES	AA	AB	AC	AF	BA	KEY
182T	9	6	4 1/2	3 3/4	2 1/4	7/16	7/16	1 3/4	1 7/8	6 13/16	4 15/16	2 13/16	9 1/8	9 1/4	—	1.125	2 1/2	2 3/4	1 7/8	3/4	7 13/16	6 9/16	3 1/8	2 3/4	1/4
184T	7	2 3/4	7 5/16	2 15/16	7 5/16	5 7/16	5 7/16																		
213T	10 1/2	7	5 1/4	4 1/4	2 3/4	7/16	7/16	2	1 7/8	8 1/8	6 3/16	3 7/16	10 1/2	10 1/2	2 5/16	1.375	3 1/8	3 1/4	2 7/16	1	9 1/4	7 5/8	3 1/2	3 1/2	5/16
215T		8 1/2			3 1/2					8 7/8	6 15/16														
254T	12 1/2	10 1/4	6 1/4	5	4 1/8	5/8	9/16	2 1/2	2 5/8	10 3/8	8 5/16	4 1/16	12 1/2	12 1/2	2 5/16	1.625	3 3/4	3 7/8	2 15/16	1 1/4	10 1/4	8 7/8	3 7/8	4 1/4	3/8
256T		12			5					11 1/4	9 3/16														
284T	13 3/4	11 1/2	7	5 1/2	4 3/4	5/8	9/16	2 1/2	2 3/4	11 13/16	9 7/16	4 11/16	14	14	2 7/16	1.875	4 3/8	4 1/2	3 1/4	1 1/2	12 1/8	10	4 7/16	4 3/4	1/2
284TS					3 5/16					3 5/16	1 15/16	3/8													
286T		4 11/16		4 11/16	3 1/4					1/2															
286TS		3 5/16		3 5/16	1 15/16					3/8															
324T	15 1/2	13 1/4	8	6 1/4	5 1/4	5/8	1 1/16	2 3/4	3 1/8	13 3/16	10 7/16	5 5/16	16	16	2 5/8	2.125	5	5 1/8	4	2	14 3/8	11 3/4	5 3/8	5 1/4	1/2
324TS					3 13/16					3 13/16	2	1.875					3 1/2	3 5/8							
326T		5 5/16		5 5/16	3					2.125	5	5 1/8					3								
326TS		3 13/16		3 13/16	2 1/16					1.875	3 1/2	3 5/8													
364T	17	15	9	7	5 5/8	7/8	1 1/16	2 3/4	3 7/8	16 11/16	11 3/8	6	18 1/2	19	12 7/16	2.375	5 5/8	5 3/4	4 1/4	3	16 1/16	13 5/16	6 7/8	5 7/8	5/8
364TS					3 7/8					3 7/8	2 1/16	1.875					3 1/2	3 5/8							
365T		6		6	4 1/4					2.375	5 5/8	5 3/4					4 1/4								
365TS		3 7/8		3 7/8	2 1/16					1.875	3 1/2	3 5/8													
405T	19	16	10	8	6 7/8	1 1/8	13/16	3 1/4	3 1/4	17 9/16	13 1/8	7 5/8	21 5/16	22 5/16	2 15/16	2.875	7	7 1/8	5 11/16	4	16 3/8	13 1/4	7 1/2	6 5/8	3/4
405TS					4 5/8					4 5/8	2 7/8	2.125					4	4 1/8	2 7/8						1/2

NEMA EXPLOSION-PROOF • 158 SERIES • C FACE DIMENSIONS (Inches)

Frame Size	A	B	D	E	F	H	L	O	P	T	U	V	AH	AJ		BB	AK	BD	BG	AA	AB	AC	AF	KEYWAY
														DIA.	BARR.									
182T	9	6	4 1/2	3 3/4	2 1/4	7/16	6 5/8	9 1/8	9 1/4	—	1.1250	2 1/2	2 5/8	7 1/4	4	9/32	8.500	8 3/4	5 7/8	3/4	9 3/8	7 1/8	2 1/2	1/4
184T		7			2 3/4		7 1/8												6 3/8					

The condensed dimensions shown on these pages are for general reference only and are not for construction. The overall length or "C" dimension for each catalog item is included in this catalog. [Certified drawings of all ratings are available for construction purposes.](#)

RIGID MOUNT G-SERIES

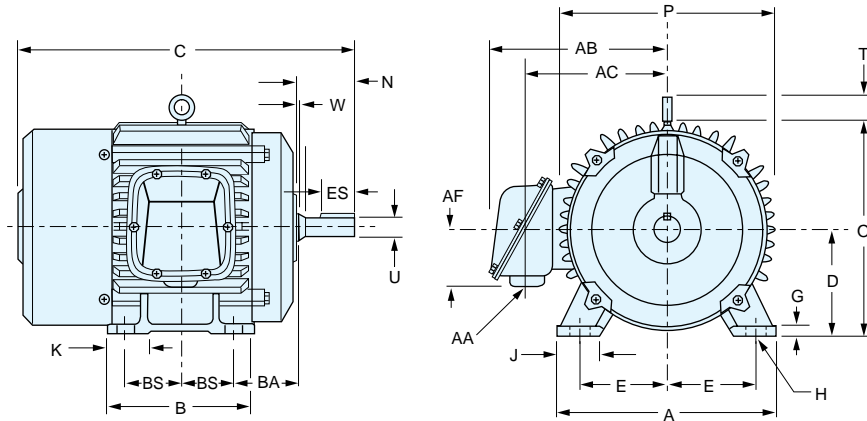

NEMA EXPLOSION-PROOF • G-SERIES • RIGID MOUNT DIMENSIONS (Inches)

Frame Size	A	B	D	E	2F*	G	H	J	K	N	O	P	T	U	N-W	ES	AA	AB	AC	AF	BA	BS	KEY	C Dim
182T 184T	8.88	7.75	—	3.75	6.75	0.45	0.41-0.46	1.56	—	2.78	9.36	9.76	2.62	1.125	2.75	1.75	0.75	9.73	7.13	—	2.75	3.37	0.25	17.12
213T 215T	10.38	8.50	5.19 5.25	4.25	7.00	0.60	0.44	1.87	—	3.41	10.60	11.50	2.62	1.375	3.38	2.38	0.75	10.94	8.32	2.55	3.50	3.50	0.31	20.18
254T 256T	12.12	10.25	6.19 6.25	5.00	8.25 10.00	0.55	0.53-0.58	2.08	—	4.19	14.07	14.12	—	1.625	4.00	2.88	1.25	13.67	10.65	3.12	4.25	4.12 5.00	0.38	23.52 25.27
284T 284TS 286T 286TS	13.00	11.50 13.00	6.94 7.00	5.50	9.50 11.00	0.88	0.53-0.58	2.50	2.50	4.81 3.44 4.81 3.44	14.74	15.50	3.25	1.875 1.625 1.875 1.625	4.62	3.25 1.88 3.25 1.88	1.50	15.33	11.44	5.38	4.75	4.75	0.50 0.38 0.50 0.38	26.30 24.94 27.80 26.44
324T 324TS 326T 326TS	15.75	13.00 14.50	7.94 8.00	6.25	10.50 12.00	0.86	0.66-0.71	3.50	—	5.50 4.00 5.50 4.00	17.10	16.00	3.25	2.125 1.875 2.125 1.875	5.25 3.75 5.25 3.75	3.88 2.00 3.88 2.00	2.00	16.50	12.64	5.38	5.25	5.25	0.50 0.50	28.87 27.37 30.37 28.87
364T 364TS 365T 365TS	17.75	13.25 14.25	8.94 9.00	7.00	11.25 12.25	1.12	0.66-0.71	4.00	3.25	6.12 4.00 6.12 4.00	19.00	20.00	3.62	2.375 1.875 2.375 1.875	5.88 3.75 5.88 3.75	4.24	2.50	19.75	14.50	5.38	5.88	5.62 6.12	0.62	31.50 29.38 32.50 30.38
405T 405TS	19.25	16.25	—	8.00	13.75	1.12	0.81-0.86	4.25	3.75	7.50 4.50	20.87	21.75	3.62	2.875 2.125	7.25 4.25	5.62 2.75	2.50	21.50	16.38	5.38	6.62	6.88	0.75 0.50	37.12 34.12
444T 444TS 445T 445TS 449T 449TS	21.50	18.00 19.75 28.25	10.94 11.00	9.00	14.50 16.50 25.00	1.25 1.22 1.25	0.81-0.86	3.75	4.50 5.12 9.88	8.75 5.00 8.75 5.00 8.75 5.00	23.12 24.11 24.19	24.25 26.31 26.31	3.62 2.44 0.77	3.375 2.375 3.375 2.375 3.375 2.375	8.50 4.75 8.50 4.75 8.50 4.75	6.88 3.00 6.88 3.00 6.88 3.00	2.50 3.00	22.75 27.24 26.09	17.50 20.06 18.88	5.38 6.18	7.50	7.25 8.25 1.78	0.88 0.62 0.88 0.62 0.88 0.62	41.25 37.50 43.19 39.44 51.69 47.97

* 182-4T and 213-5T frames have eight-hole bases. 449T and TS frames have six-hole bases. Others have four-hole bases.

RIGID MOUNT 150 & 170 SERIES

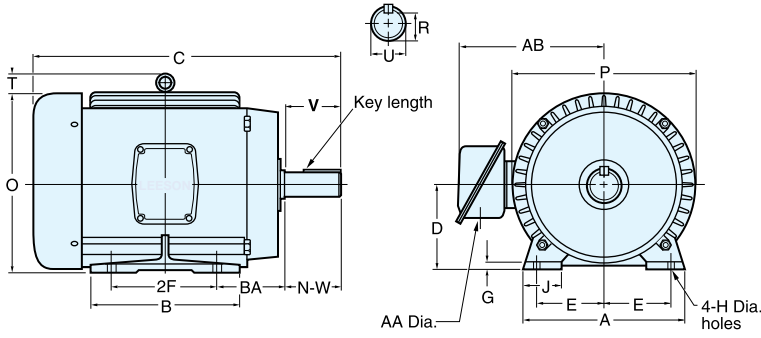

NEMA SHAFT AND KEYWAY DIMENSIONS (Inches)

NEMA SHAFT (U)	KEYWAY DIMENSIONS (R)	(S)	NEMA SHAFT (U)	KEYWAY DIMENSIONS (R)	(S)
3/8	21/64	FLAT	1-7/8	1-19/32	1/2
1/2	29/64	FLAT	2-1/8	1-27/32	1/2
5/8	33/64	3/16	2-3/8	2-1/64	5/8
7/8	49/64	3/16	2-1/2	2-3/16	5/8
1-1/8	63/64	1/4	2-7/8	2-29/64	3/4
1-3/8	1-13/64	5/16	3-3/8	2-7/8	7/8
1-5/8	1-13/32	3/8	3-7/8	3-5/16	1

■ S is keyway width.
U minus R is keyway depth.

C FACE 150 & 170 SERIES

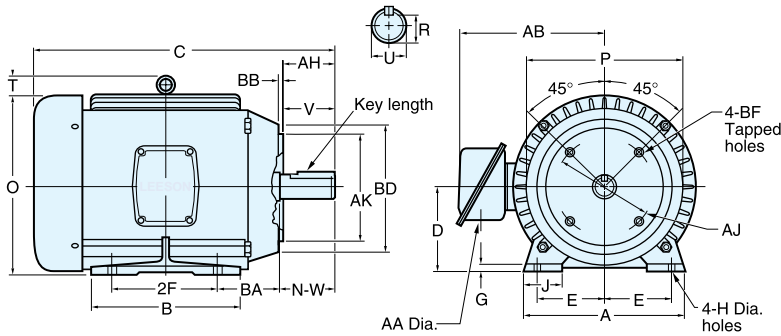

NEMA CAST IRON FRAME • 150 & 170 SERIES DIMENSIONS (Inches)

Frame Size ▲	B		D	E	2F	H	N	O	P	U	N-W	AA	AB	AH	AJ	AK	BA	BB	BD	T	T	TAP	KEY	
	TEFC	ODP																		ODP	TS	**		
182T	7/4	67/8	4 1/2	3 3/4	4 1/2	13/32	2 7/8	8 3/4	8 5/32	1 1/8	2 3/4	3/4	6 3/8	2 5/8	7 1/4	8 1/2	*2 3/4	1/4	8 7/8	1 9/16	2 1/2	1/2-13	1/4	
184T					5 1/2															1 3/4				
213T	7 1/2	7 1/2	5 1/4	4 1/4	5 1/2	13/32	—	10 11/16	10 13/16	1 3/8	3 3/8	1	8 5/16	3 1/8	7 1/4	8 1/2	*3 1/2	1/4	9	1 15/16	3 1/8	1/2-13	5/16	
215T	9	9			7														2					
254T	10 3/8	10 3/8	6 1/4	5	8 1/4	17/32	—	12 15/16	13 1/4	1 5/8	4	1 1/4	11 5/8	3 3/4	7 1/4	8 1/2	*4 1/4	1/4	9 5/8	2 19/32	3 3/4	1/2-13	3/8	
256T	12 1/8	12 1/8			10															2 11/16				
284TS	11 3/4	11 3/4	7	5 1/2	9 1/2	17/32	—	14 1/2	14 3/4	1 5/8	3 1/4	1 1/2	11 3/4	3	9	10 1/2	4 3/4	1/4	11	2 19/32	4 3/8	1/2-13	3/8	
284T																								
286TS	13 1/4	13 1/4			11					1 5/8	3 1/4			3						3 1/8	3		3/8	
286T																								
324TS	12 7/8	13 3/8	8	6 1/4	10 1/2	2 1/32	—	15 3/4	15 3/4	1 7/8	3 3/4	2	13 1/2	3 1/2	11	12 1/2	5 1/4	1/4	13 3/8	2 3/4	5	5/8-11	1/2	
324T																								
326TS	14 3/8	14 7/8			12					2 1/8	5 1/4			5						2 3/16	3 1/2	3/8	1/2	
326T																								
364TS	13 3/8	14 7/16	9	7	11 1/4	2 1/32	—	17 13/16	16	1 7/8	3 3/4	3	15 7/16	3 1/2	11	12 1/2	5 7/8	1/4	14	2 1/2	5 5/8	5/8-11	1/2	
364T																								
365TS	14 3/8	15 7/16			12 1/4					1 7/8	3 3/4			3 1/2						2 13/16	3 1/2	3/8	1/2	
365T																								
404TS	15 15/16	15 15/16	10	8	12 1/4	13/16	—	19 5/16	19 1/8	2 1/8	4 1/4	3	16 5/16	4	11	12 1/2	6 5/8	1/4	15 1/2	2 25/32	7	5/8-11	1/2	
404T																								
405TS	17 7/16	17 7/16			13 3/4					2 1/8	4 1/4			7						3 1/8	4	3/8	1/2	
405T																								
444T	18 11/16	20 5/8	11	9	14 1/2	13/16	—	22 1/4	22	3 3/8	8 1/2	3	21 11/16	8 1/4	14	16	7 1/2	1/4	18	3	8 1/4	5/8-11	7/8	
444TS																								
445T	20 5/8	20 5/8			16 1/2					2 3/8	4 3/4			3 3/8						3 3/4	4 1/2	3/8	7/8	
445TS																								
447T	24 3/8	29 1/8	11	9	20	13/16	—	24 1/4	26 1/2	3 3/8	8 1/2	3	25 15/16	8 1/4	14	16	7 1/2	1/4	18	3 3/16	8 1/4	5/8-11	7/8	
449T																								

* 182-184TC NEMA C face BA dimension is 3 1/2". 213-215TC NEMA C face BA dimension is 4 1/4". 254-256TC NEMA C face BA dimension is 4 3/4".
 ** 326TC and smaller have 4 mounting holes in NEMA C face, 364TC and larger have 8 mounting holes.
 ▲ Blue shading denotes dimensions established by NEMA standard MG1, others are unique to LEESON, and will vary with each manufacturer.

Dimensions



DIMENSIONS

SPEEDMASTER® INVERTER MOTORS

TENV—C FACE, RIGID BASE

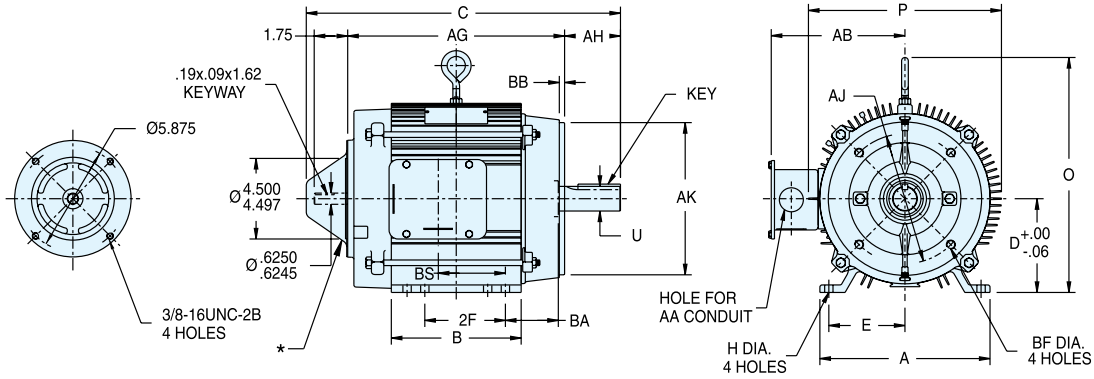

TENV • C FACE • RIGID BASE • DIMENSIONS (Inches)

Frame Size	D	E	2F	H	O MAX.	P MAX.	U	AA	AB MAX.	AG MAX.	AH	AJ	AK	BA	BB	BF	BS	KEY
143TC	3.50	2.75	4.00	.38	7.45	7.98	.875	1.09	7.04	9.25	2.12	5.875	4.50	2.62	.13	3/8-16	2.81	.19 x .19 x 1.38
145TC	3.50	2.75	5.00	.35	7.45	7.98	.875	1.09	7.04	10.25	2.12	5.875	4.50	2.62	.13	3/8-16	3.81	.19 x .19 x 1.38
182TC	4.50	3.75	4.50	.41	9.36	9.76	1.125	1.09	8.08	11.75	2.62	7.250	8.50	3.50	.27	1/2-13	2.25	.25 x .25 x 1.75
184TC	4.50	3.75	5.50	.41	9.36	9.76	1.125	1.09	8.08	12.75	2.62	7.250	8.50	3.50	.27	1/2-13	2.75	.25 x .25 x 1.75
213TC	5.25	4.25	5.50	.44	10.97	11.50	1.375	1.09	9.31	15.12	3.12	7.250	8.50	4.25	.27	1/2-13	3.50	.31 x .31 x 2.38
215TC	5.25	4.25	7.00	.44	10.97	11.50	1.375	1.09	9.31	17.31	3.12	7.250	8.50	4.25	.27	1/2-13	6.18	.31 x .31 x 2.38
254TC	6.25	5.00	8.25	.53	14.09	14.27	1.625	1.25	9.83	19.06	3.75	7.250	8.50	4.75	.27	1/2-13	6.31	.38 x .38 x 2.88
256TC	6.25	5.00	10.00	.56	14.09	14.27	1.625	1.25	11.08	18.82	3.75	7.250	8.50	4.75	.27	1/2-13	5.00	.38 x .38 x 2.88
284TC	7.00	5.50	9.50	.56	14.16	14.32	1.875	1.50	12.31	20.57	4.38	9.000	10.50	4.75	.27	1/2-13	5.50	.50 x .50 x 3.25

TEBC—TOTALLY ENCLOSED BLOWER COOLED, RIGID BASE

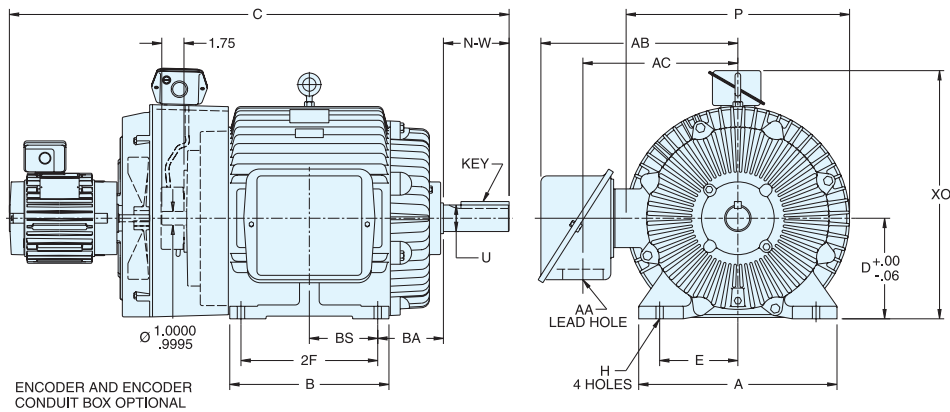

TEBC • TOTALLY ENCLOSED BLOWER COOLED • RIGID BASE • DIMENSIONS (Inches)

Frame Size	D	E	2F	H	O MAX.	P MAX.	U	AA	AB MAX.	AC MAX.	BA	BS	FU	N-W	KEY
325T	8.00	6.25	10.50	.66	16.00	15.88	2.12	2.00	13.69	10.69	5.25	5.25	1.00	5.25	.50 x .50 x 3.88
326T	8.00	6.25	12.00	.66	16.00	15.88	2.12	2.00	13.69	10.69	5.25	6.00	1.00	5.25	.50 x .50 x 3.88
364T	9.00	7.00	11.25	.66	19.00	20.00	2.38	3.62	17.85	14.56	5.88	5.62	1.00	5.88	.62 x .62 x 4.25
365T	9.00	7.00	12.25	.66	19.00	20.00	2.38	3.62	17.85	14.56	5.88	6.12	1.00	5.88	.62 x .62 x 4.25
404T	10.00	8.00	12.25	.81	20.88	21.75	2.88	3.62	18.75	14.75	6.62	6.12	1.00	7.25	.75 x .75 x 5.62
405T	10.00	8.00	13.75	.81	20.88	21.75	2.88	3.62	19.75	16.25	6.62	6.88	1.00	7.25	.75 x .75 x 5.62
444T	11.00	9.00	14.50	.81	24.19	25.31	3.38	3.62	20.94	17.38	7.50	7.25	1.00	8.50	.88 x .88 x 6.88
445T	11.00	9.00	16.50	.81	24.19	26.31	3.38	3.62	20.94	17.38	7.50	8.25	1.00	8.50	.88 x .88 x 6.88
449T	11.00	9.00	25.00	.81	24.22	26.31	3.38	4.62	25.90	19.31	7.50	1.78	1.00	8.50	.88 x .88 x 6.88

Dimensions

RIGID MOUNT

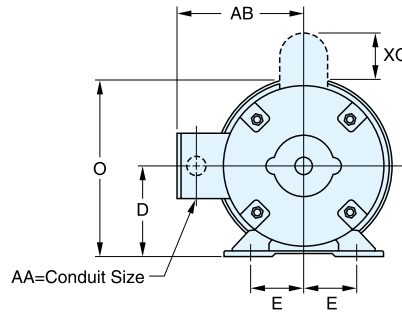
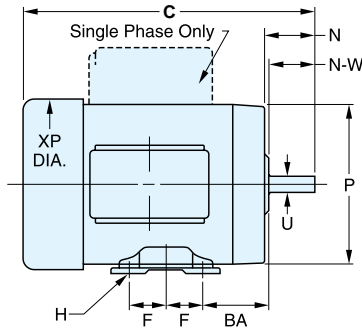

The condensed dimensions shown on these pages are for general reference only and are not for construction. The overall length or "C" dimension for each catalog item is included in this catalog. **Certified drawings of all ratings are available for construction purposes.**

C FACE

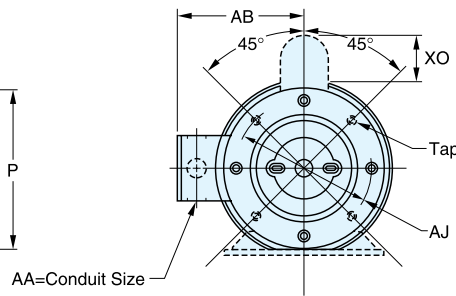
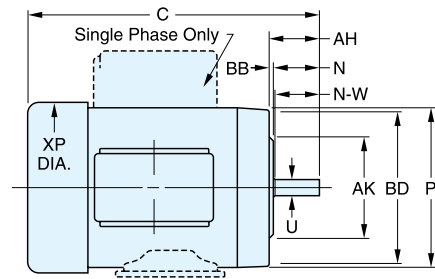

NEMA SHAFT AND KEYWAY DIMENSIONS ■ (Inches)

NEMA SHAFT (U)	KEYWAY DIMENSIONS (R)	KEYWAY DIMENSIONS (S)	NEMA SHAFT (U)	KEYWAY DIMENSIONS (R)	KEYWAY DIMENSIONS (S)
3/8	21/64	FLAT	1-7/8	1-19/32	1/2
1/2	29/64	FLAT	2-1/8	1-27/32	1/2
5/8	33/64	3/16	2-3/8	2-1/64	5/8
7/8	49/64	3/16	2-1/2	2-3/16	5/8
1-1/8	63/64	1/4	2-7/8	2-29/64	3/4
1-3/8	1-13/64	5/16	3-3/8	2-7/8	7/8
1-5/8	1-13/32	3/8	3-7/8	3-5/16	1

■ S is keyway width.
U minus R is keyway depth.

NEMA STEEL FRAME DIMENSIONS (Inches)

Frame Size ▲	D	E	F	H	N	O	P	U	N-W	AA	AB	AH	AJ	AK	BA	BB	BD	XO	XP	TAP **	KEY
42	2 ⁵ / ₈	1 ³ / ₄	2 ⁷ / ₃₂	9 ³ / ₃₂ Slot	1 ¹ / ₄	5 ¹ / ₁₆	4 ⁷ / ₈	3 ³ / ₈	1 ¹ / ₈	3 ³ / ₈	4 ¹ / ₂	1 ⁵ / ₁₆	3 ³ / ₄	3	2 ¹ / ₁₆	1 ¹ / ₈	4 ⁷ / ₈	1 ⁵ / ₈	5 ¹ / ₈	1 ¹ / ₄ -20	3 ⁵ / ₁₆ Flat
48	3	2 ¹ / ₈	1 ³ / ₈	1 ¹ / ₃₂ Slot	1 ⁹ / ₁₆	5 ¹³ / ₁₆	5 ¹⁹ / ₃₂	1 ¹ / ₂	1 ¹ / ₂	1 ¹ / ₂	4 ⁷ / ₈	1 ¹¹ / ₁₆	3 ³ / ₄	3	2 ¹ / ₂	1 ¹ / ₈	5	2 ¹ / ₄	5 ⁷ / ₈	1 ¹ / ₄ -20	3 ⁵ / ₁₆ Flat
S56 56	3 ¹ / ₂	2 ⁷ / ₁₆	1 ¹ / ₂	1 ¹ / ₃₂ Slot	1 ¹⁵ / ₁₆	6 ⁵ / ₁₆ 6 ¹³ / ₁₆	5 ¹⁹ / ₃₂ 6 ¹⁹ / ₃₂	5 ⁵ / ₈	1 ⁷ / ₈	1 ¹ / ₂	4 ⁷ / ₈ 5 ⁵ / ₁₆	2 ¹ / ₁₆	5 ⁷ / ₈	4 ¹ / ₂	2 ³ / ₄	1 ¹ / ₈	6 ¹ / ₂	2 ¹ / ₄	5 ⁷ / ₈ 7 ⁵ / ₃₂	3 ⁵ / ₈ -16	3 ¹ / ₁₆
143T 145T	3 ¹ / ₂	2 ³ / ₄	2 2 ¹ / ₂	1 ¹ / ₃₂	2 ³ / ₈	6 ¹³ / ₁₆	6 ¹⁹ / ₃₂	7 ¹ / ₈	2 ¹ / ₄	3 ³ / ₄	5 ⁵ / ₁₆	2 ¹ / ₈	5 ⁷ / ₈	4 ¹ / ₂	*2 ¹ / ₄	1 ¹ / ₈	6 ¹ / ₂	2 ¹ / ₄	7 ⁵ / ₃₂	3 ⁵ / ₈ -16	3 ¹ / ₁₆
182T 184T	4 ¹ / ₂	3 ³ / ₄	2 ¹ / ₄ 2 ³ / ₄	1 ³ / ₃₂	2 ⁷ / ₈	8 ³ / ₄	8 ¹⁵ / ₃₂	1 ¹ / ₈	2 ³ / ₄	3 ³ / ₄	6 ⁷ / ₁₆	2 ⁵ / ₈	7 ¹ / ₄	8 ¹ / ₂	*2 ³ / ₄	1 ¹ / ₄	8 ⁷ / ₈	2 ¹ / ₄	9 ⁷ / ₃₂	1 ¹ / ₂ -13	1 ¹ / ₄
S213T 213T 215T	5 ¹ / ₄	4 ¹ / ₄	2 ³ / ₄ 2 ³ / ₄ 3 ¹ / ₂	1 ³ / ₃₂	3 ¹ / ₂ —	9 ²⁷ / ₃₂ 10 ⁵ / ₈	8 ¹³ / ₃₂ 9 ²¹ / ₃₂	1 ³ / ₈ 3 ³ / ₈	3 ³ / ₈	3 ³ / ₄	7 ¹⁹ / ₃₂	3 ¹ / ₈	7 ¹ / ₄	8 ¹ / ₂	*3 ¹ / ₂	1 ¹ / ₄	8 ⁷ / ₈ 8 ⁵ / ₈	2 ¹ / ₄	9 ⁷ / ₃₂ 10 ¹⁹ / ₁₆	1 ¹ / ₂ -13	5 ¹ / ₁₆

* 143-5TC NEMA C face BA dimension is 2³/₄". 182-4TC NEMA C face BA dimension is 3¹/₂". 213-5TC NEMA C face BA dimension is 4¹/₄".
** 326TC and smaller have 4 mounting holes in NEMA C face, 364TC and larger have 8 mounting holes.

▲ Blue shading denotes dimensions established by NEMA standard MG1, others are unique to LEESON, and will vary with each manufacturer.

Split-Phase Motors - 191868, 191869 & 191870 (page 50)

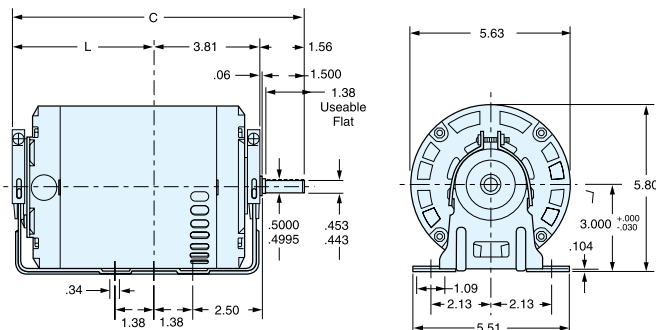

Pedestal Fan Motors (page 50)

Note: Motors with U = .625 have a 3/16" keyway.

