

Lightning & Surge Protection

Contents

1. What is Lightning? How to Protect Instruments?	2
1-1. Where can lightning enter into a system?	2
1-2. Which arrester do you choose?	2
1-3. Induced lightning surges	2
1-4. Electrostatic field	3
1-5. Magnetic field	3
1-6. What effect does lightning have?	4
1-7. The surge absorber element	4
1-8. The discharge element	5
1-9. Correct use of lightning arresters	5
2. FAQ for Lightning Arresters	6
Q1. Is there a way to protect electronic instruments from a direct lightning strike?	6
Q2. A remote field transmitter connected to a local indicator which is protected by a lightning arrester begins to show inconsistent display values. What could be the trouble?	7
Q3. A control room instrument was damaged during a recent lightning strike. What can be done to prevent this damage in the future?	8
Q4. A transmitter that is attached to a panel located indoors was damaged by a recent lightning strike. Can you explain why this occurred?	9
Q5. Is a lightning arrester necessary for a power source line?	10
Q6. During a recent lightning storm, the power was turned off but some instruments were still damaged. Can you explain this?	11
Q7. An instrument was blackened by a lightning strike via a lightning rod. Is there a reason for this?	12
Q8. It has been said that if you use buried cables, then that is enough protection from lightning. Is this a true statement?	13
Q9. How much resistance is appropriate when grounding the M-RESTER?	14
Q10. Is an instrument safe if the lightning arrester on the power supply line is damaged?	15
Q11. A field transmitter was connected to a lightning arrester, but it was still damaged by a lightning strike. Can you tell me why?	16
Q12. After a lightning storm, there was no input from the remote RTD sensor to the temperature transmitter. There is no detectable damage to the transmitter. What could have happened?	17
3. Connection Examples	18

1. What is Lightning? How to Protect Instruments?

Computers and electronic instruments are essential for processing various kinds of information in a high speed manner. However, they are often subject to the induced energy caused by lightning, because of their generally low dielectric strength.

Lightning is a phenomenon in which negative electric charges generated in a thunderstorm discharge to the ground as a result of dielectric breakdown in the air. A lightning surge, even an indirect one, induces a surge voltage on the cable lines, and transmits a momentary high voltage impulse to the sensors/transmitters in the field, or to the inputs of computers and instruments in the control room.

1-1. Where can lightning enter into a system?

Lightning surges typically enter into an instrumentation system through the signal cables and power cables, which are often connected from one building to another. The effects of induced surges on a connected device will be more severe when the connected cable is longer and the device is located closer to the place where the actual lightning strikes. A lightning strike which occurred a distance away from the electronic equipment could still cause severe damage. Even lightning rods with minimal cable lengths do not always protect as they are hoped. The effects of lightning surges differ according to the location of cable and the environment. Lightning arresters installed in these paths absorb and eliminate the high voltage impulse energy and protect the electronic equipment from damage.

1-2. Which arrester do you choose?

A 4 – 20mA DC signal is transmitted through a cable for a 2-wire system with 24V DC power. A pair of lightning arresters of the same specifications are installed at both ends of the cable, because both the sensor and the receiving instrument incorporate electronic circuits that can be damaged.

Lightning arresters should be installed for an RTD, even though it has no electronic circuit within itself, in order to prevent the probe from wire breakdown. This is especially important if the RTD is installed in a critical, continuous operation loop.

Lightning arresters are available for other specific applications such as thermocouples, potentiometers, strain gauges, telemetry and multiplex transmission systems.

Lightning arresters for power supply lines are designed not to interfere with the commercial power line frequency. In addition, they are equipped with an overload protection circuit which ensures continuous current flow even if the lightning discharge element is destroyed.

1-3. Induced lightning surges

When electric charges are accumulated in thunderclouds, a dielectric breakdown which causes discharging between clouds or between a cloud and the ground eventually occurs.

At the same time, an abnormally high voltage is induced through power transmission cables or communication cables located close to where such discharge occurred.

1-4. Electrostatic field

When thunderclouds located above a power transmission cable or communication cable contain negative charges at the bottom, high level positive charges are induced electrostatically within the cable (Figure 4-1).

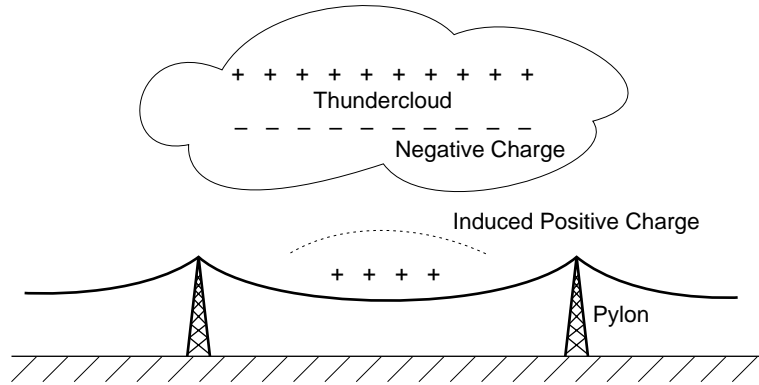

Figure 4 – 1

When a discharge between clouds or to the ground occurs, it dissipates negative charges inside the clouds, and within the cable the positive charges are freed and flow in both directions (Figure 4-2).

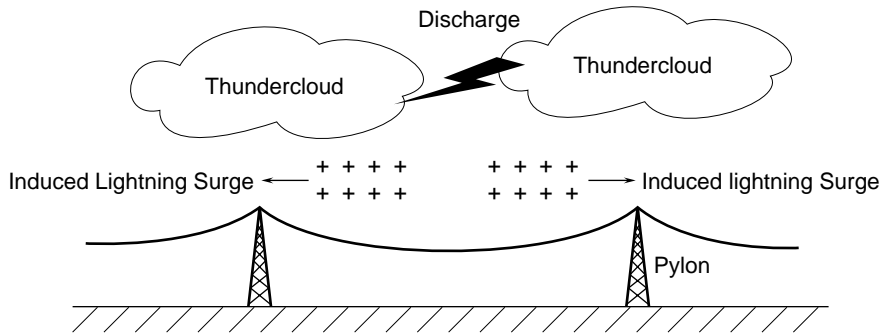

Figure 4 – 2

1-5. Magnetic field

A discharge between clouds and the ground close to a power transmission cable or communication cable generates a magnetic field due to a surge current. When the magnetic waves propagated within the field reach the cable, a lightning surge is induced (Figure 5-1).

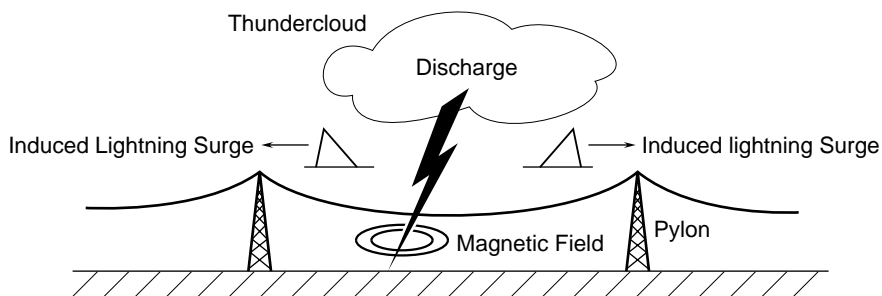

Figure 5 – 1

1-6. What effect does lightning have?

Lightning occurs at a voltage typically as high as five thousand volts between the cable and ground, while it induces several hundred volts between lines. The lightning-induced surge can propagate in the cable and instantaneously apply violent energy to electronic equipment connected to both ends of the cable. Examination of electronic instruments destroyed by lightning surges tells us that there are two kinds of breakdowns that occur: **interline breakdown** and **discharge breakdown**.

• Interline breakdown (V_1)

This occurs when the surge voltage between cables is directly applied to the electronic components in the instrument. Usually, only those components that are located near the termination of the cable where the surge entered are destroyed.

• Discharge breakdown (V_2 , V_3)

Lightning surges cause a very high potential difference (voltage) between two conductors and ground, and a discharge occurs between some part of an electronic circuit and those electrically connected to ground, such as metal cases. Electronic components become damaged because some of the discharge current flows through the electronic circuit (Figure 6-1).

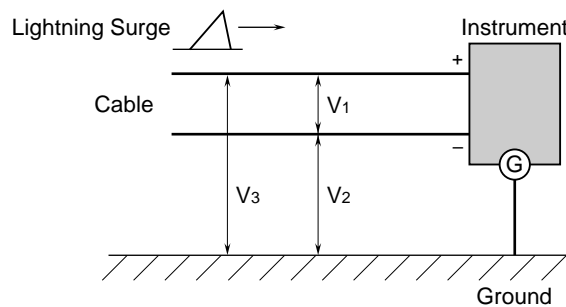

Figure 6 – 1

1-7. The surge absorber element

As shown in the figures below, the surge voltage V_s is limited to the voltage V_c when a discharge current flows through the surge absorber element. The discharge current value is determined by the impedance Z_s and the surge voltage V_s (Figure 7-1).

The withstand voltage of the protected instrument must be higher than the maximum surge voltage V_c (Figure 7-2).

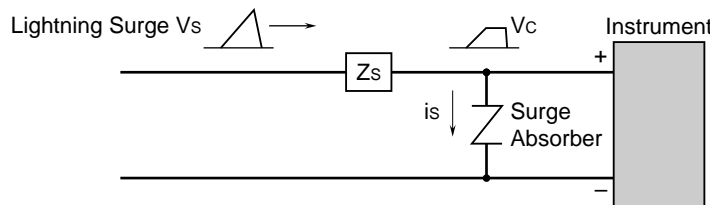

Figure 7 – 1

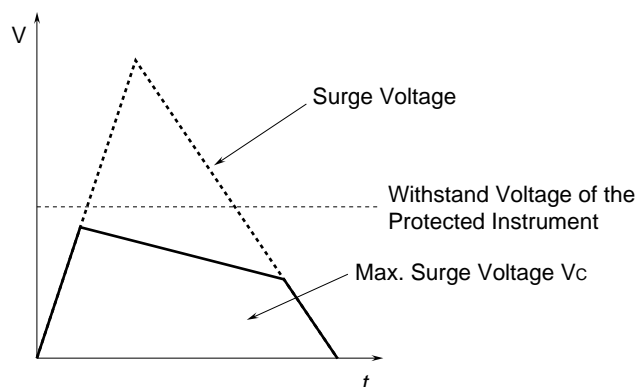

Figure 7 – 2

1-8. The discharge element

The SR Gas Tube Arrester is composed of two electrodes and a ceramic tube with inert gases such as argon, helium, neon, etc. sealed inside.

The insulating envelope of the gas tube arrester is superior to other arresters in mechanical strength, heat and shock resistance, calminating in a dependable, high performance arrester (Figure 8-1).

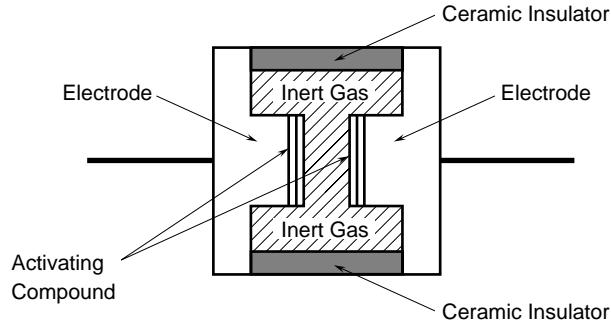

Figure 8 – 1

1-9. Correct use of lightning arresters

Grounding is important for stable performance and safety of computer systems and electronic instruments. There must be no potential difference between the ground terminals of the lightning arrester and the protected instrument. The use of a ground strap or crossover wire is necessary if such a potential does occur in order to assure a proper discharge path for the lightning surge (Figure 9-1).

Before performing the insulation test for an instrument panel equipped with lightning arresters, you must disable the arresters because they will start discharging during the test and possibly cause insulation failures. For signal line arresters, simply unplug the element from the base socket. Due to its unique design, the socket causes the input and output to be shorted when the element is not installed. This minimizes system "down time" if an element fails in the field due to a lightning strike. For power line arresters, remove all grounding wires connected to the ground terminal. Be sure to re-connect all wires after the testing is completed.

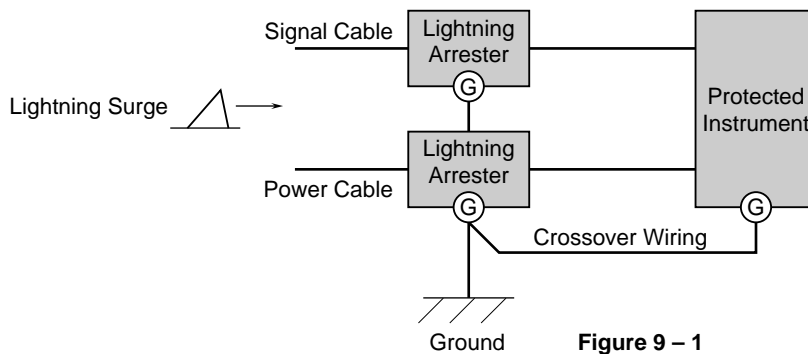

Figure 9 – 1

2. FAQ for Lightning Arresters



Is there a way to protect electronic instruments from a direct lightning strike?



Nothing can protect from a direct lightning strike. A lightning rod is the only way to divert direct strikes.

DISCUSSION

With existing electronic technology, there is no way to protect instrumentation from a direct lightning strike. A lightning rod or overhead grounding wire is still the best protection available from the severity of a direct lightning strike. These protect by shielding electrical conductors and instruments within the protected area.

• Lightning rod

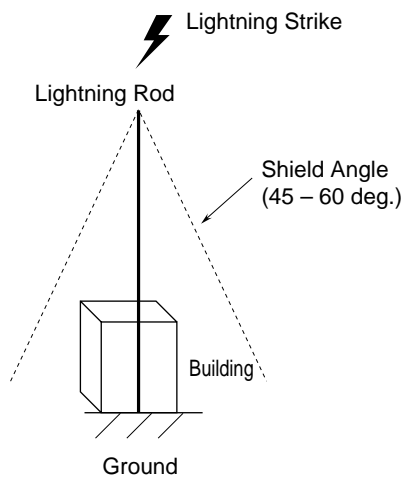

• Overhead grounding wire

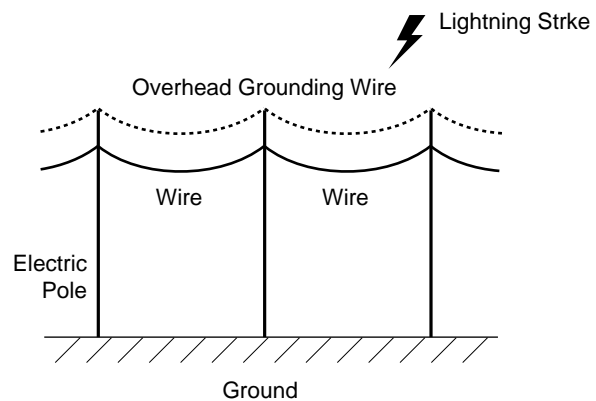

• Lightning rod

This is set up for buildings with heights greater than 60 feet. It protects electrical instruments from direct lightning strikes by floating the surge's current with respect to ground. The shield angle range is between 45 – 60 degrees conic. Simply burying cables is not effective due to the induced electromotive force that occurs around the cable because of impulse current in the ground near a lightning strike.

• Overhead grounding wire

This is a grounding wire which is attached to an overhead transmission line. Its effect is similar to having several lightning rods in a row which shields the lines under them from the lightning strike.



A remote field transmitter connected to a local indicator which is protected by a lightning arrester begins to show inconsistent display values. What could be the trouble?



It may be time to replace the arrester due to its lessened capacity, if the problems just started recently. Each lightning arrester has a different lifetime, less capacity time. Lightning arresters, which have been installed in areas where lightning occurs frequently, should be tested and changed periodically. Replacing the arrester with a new one in this instance may solve the problem.

DISCUSSION

Lightning arresters can be thought of as consumable items in areas where lightning is common. We would recommend for you to periodically check your lightning arresters and keep enough replacements on hand for the next lightning season. M-System's model C-106A-1 M-Rester tester can be used to check most lightning arresters for proper function.

QUESTION
Q3

A control room instrument was damaged during a recent lightning strike. What can be done to prevent this damage in the future?

ANSWER
A

If possible, determine exactly where the lightning entered the instrument. In all probability, it entered through the input signal line or power supply line. We would recommend that you use an arrester on both the signal and power supply lines. Contact your local sales office for specific models for your application.

DISCUSSION

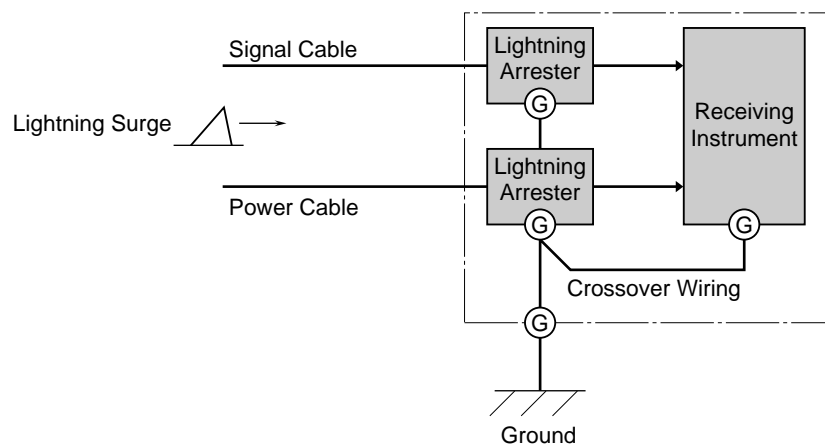

Recommended models:

- Model MDP-24-1 (4 – 20mA DC signal lines)
- Model MA-100 (100 – 120V AC, 2A power supply)
- Model MA-200 (200 – 240V AC, 2A power supply)
- Model MAX-100 (100 – 120V AC, 5A power supply)
- Model MAX-200 (200 – 240V AC, 5A power supply)

QUESTION
Q4

A transmitter that is attached to a panel located indoors was damaged by a recent lightning strike. Can you explain why this occurred?

ANSWER
A

Signals and power sources are commonly connected to a transmitter through outdoor cable pits and conduit pipes. It sounds like the lightning surge damaged the transmitter by means of these lines. If the transmitter's output is sent outdoors, then install lightning arresters to protect the input, power *and output* lines.

DISCUSSION

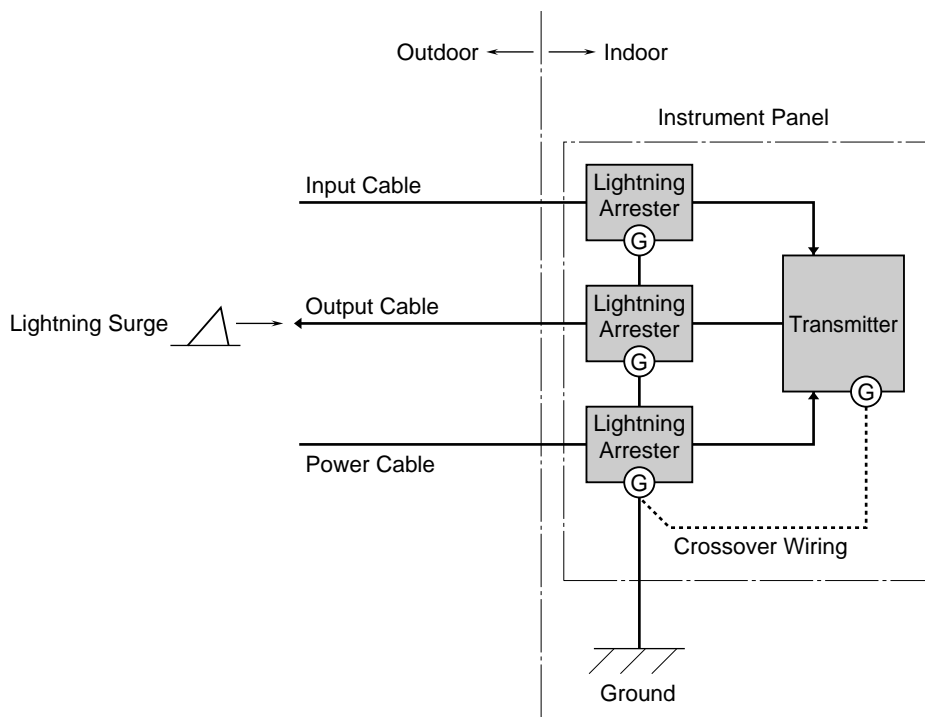

Recommended models:

- Model MDP-24-1 (4 – 20mA DC signal lines)
- Model MA-100 (100 – 120V AC, 2A power supply)
- Model MA-200 (200 – 240V AC, 2A power supply)
- Model MAX-100 (100 – 120V AC, 5A power supply)
- Model MAX-200 (200 – 240V AC, 5A power supply)

QUESTION
Q5

Is a lightning arrester necessary for a power source line?

ANSWER
A

Yes, spikes and surges often propagate through power lines.

DISCUSSION

The most likely place for a lightning strike is the power distribution cables. These spread in all directions, like a spider's web, acting similar to an antenna waiting to receive its signal. Please select the appropriate arrester for your specific application and power requirements.

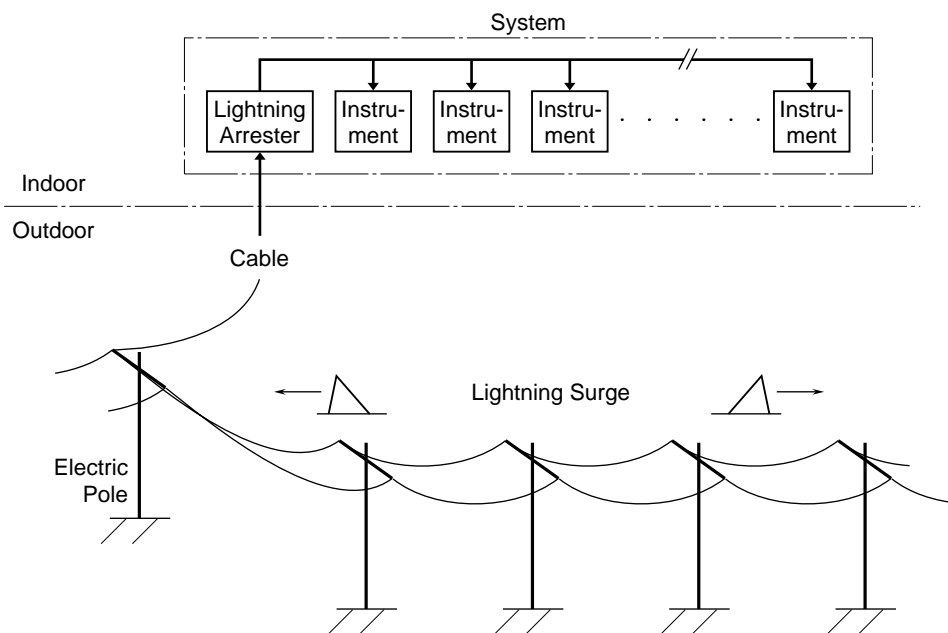

Recommended models:

<u>Model</u>	<u>Power Supply</u>	<u>Load Capacity</u>	<u>Model</u>	<u>Power Supply</u>	<u>Load Capacity</u>
MA-100	100 – 120V AC	2A	MH-105A	100 – 120V AC	5A
MA-200	200 – 240V AC	2A	MH-110A	100 – 120V AC	10A
MAX-100	100 – 120V AC	5A	MH-130A	100 – 120V AC	30A
MAX-200	200 – 240V AC	5A	MH-205A	200 – 240V AC	5A
MMA-100	100 – 120V AC	10A	MH-210A	200 – 240V AC	10A
MMA-200	200 – 240V AC	10A	MH-230A	200 – 240V AC	30A
			MH-1201	100 – 120V AC	200A
			MH-2201	200 – 240V AC	200A
			MH-2203	200 – 240V AC	200A

QUESTION
Q6

During a recent lightning storm, the power was turned off but some instruments were still damaged. Can you explain this?

ANSWER
A

Lightning jumped across the single-pole switch into the instrumentation. We would recommend to use a double-pole switch. However, this does not insure that a severe lightning surge will not damage it depending on the insulation resistance of the switch or the size of the lightning pulse. The only sure solution is to install a lightning arrester in line with the power source.

DISCUSSION

• Single-pole switch

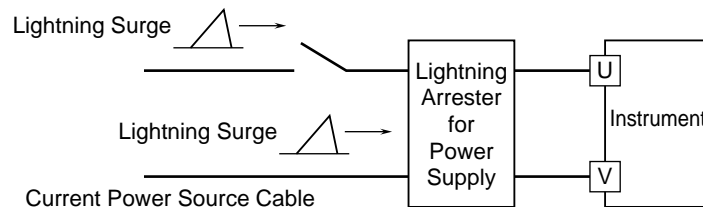

• Double-pole switch

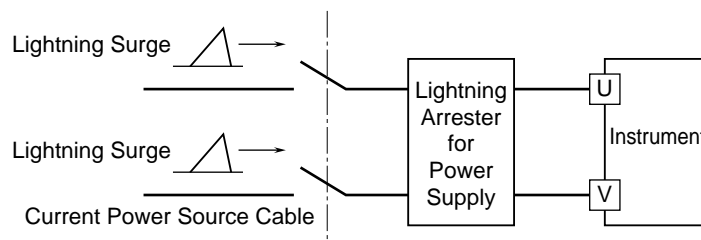

Recommended models:

- Model MA-100 (100 – 120V AC, 2A power supply)
- Model MA-200 (200 – 240V AC, 2A power supply)
- Model MAX-100 (100 – 120V AC, 5A power supply)
- Model MAX-200 (200 – 240V AC, 5A power supply)



An instrument was blackened by a lightning strike via a lightning rod. Is there a reason for this?

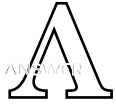

It seems like the lightning rod and the lightning arrester (instrument) share a common ground. We would recommend to separate their grounds from each other.

DISCUSSION

The large lightning surge energy has caused an isolation breakdown in the instrument. The lightning strike enters the instrument through the ground line of the lightning rod. The instrument's ground and the lightning rod's ground should have enough distance separation between them.

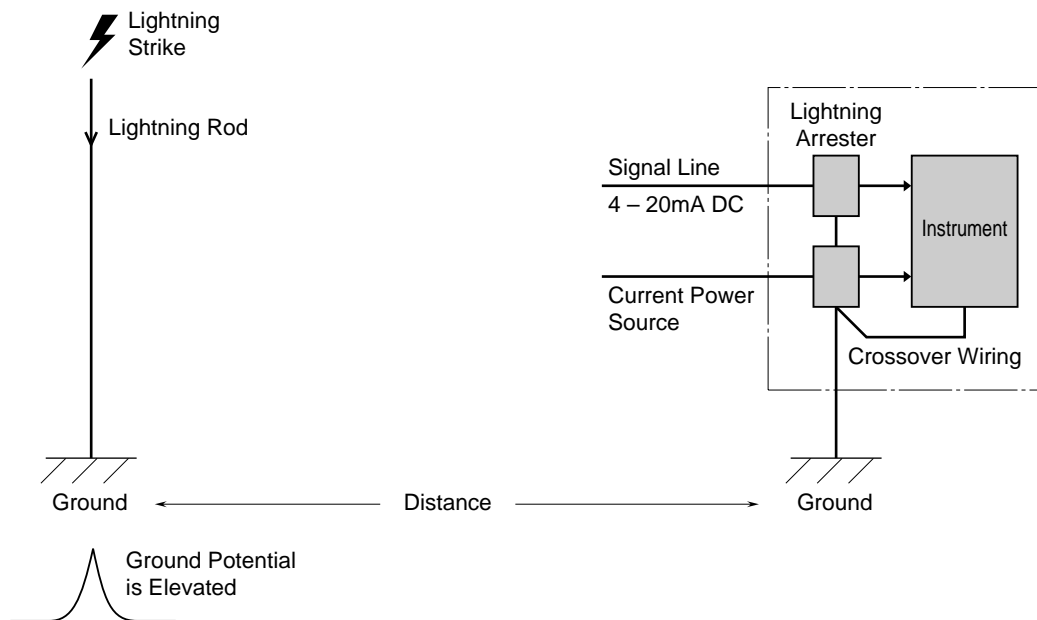

Recommended models:

- Model MDP-24-1 (4 – 20mA DC signal line)
- Model MA-100 (100 – 120V AC, 2A power supply)
- Model MA-200 (200 – 240V AC, 2A power supply)
- Model MAX-100 (100 – 120V AC, 5A power supply)
- Model MAX-200 (200 – 240V AC, 5A power supply)

QUESTION
Q8

It has been said that if you use buried cables, then that is enough protection from lightning. Is this a true statement?

ANSWER
A

No, because buried cables are also vulnerable to the unpredictable power of lightning.

DISCUSSION

A buried cable does not have as much protection from induced lightning as one might expect, because underground soil easily transmits an electromagnetic field which occurs during a lightning discharge. Also, the high lightning current that is being discharged to *ground* by the lightning rod can find its way to the buried cables located in the ground.

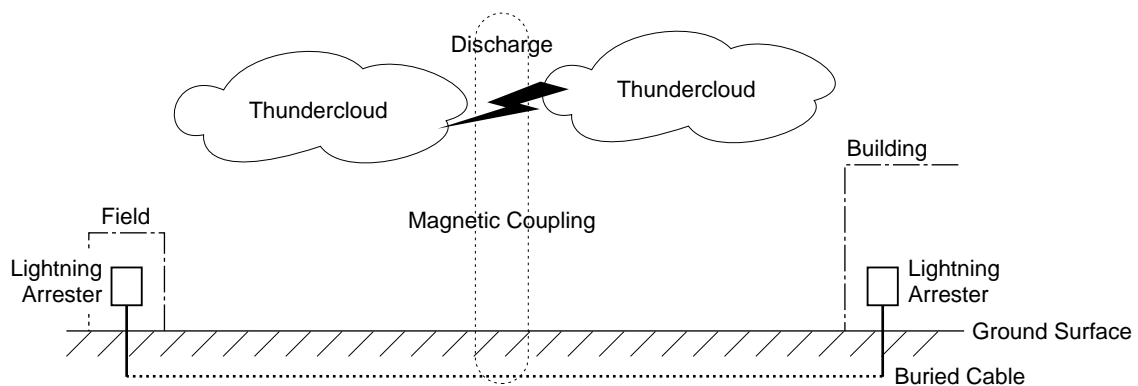

Recommended models:

- Model MDP-24-1 (4 – 20mA DC signal line)
- Model MA-100 (100 – 120V AC, 2A power supply)
- Model MA-200 (200 – 240V AC, 2A power supply)
- Model MAX-100 (100 – 120V AC, 5A power supply)
- Model MAX-200 (200 – 240V AC, 5A power supply)

QUESTION
Q9

How much resistance is appropriate when grounding the M-RESTER?



100 ohms or less.

DISCUSSION

The important thing to remember is that the device ground should be connected with a crossover wire. Then ground is at the potential lightning site. As a result, between the signal line and the ground terminal (G) of an instrument, discharge voltage (V_e) of the lightning arrester can be added.

• **Separate wiring**

A common-mode voltage V_1 , ground resistance (R) \times lightning surge current (i), is added to discharge voltage V_2 at the lightning arrester between the signal line and a ground terminal of an instrument. It may go over the withstand voltage of the instrument.

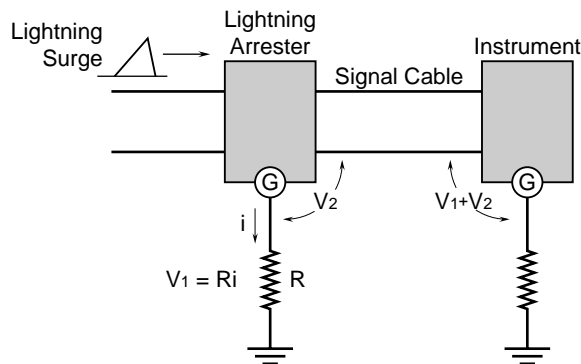

• **Wiring at instrument site**

Voltage V_1 , suitable to a drop in voltage at a connected ground point, is added to discharge voltage V_2 at the lightning arrester, then added between the signal line and a ground terminal of an instrument.

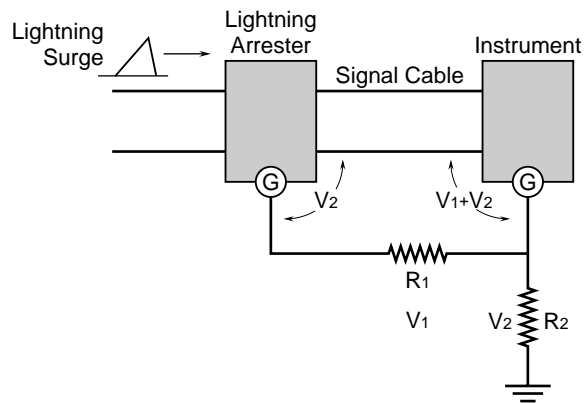

• **Crossover wiring**

Only discharge voltage in a lightning arrester site can be added to the space between the common and the signal line of an instrument. The instrument should be protected.

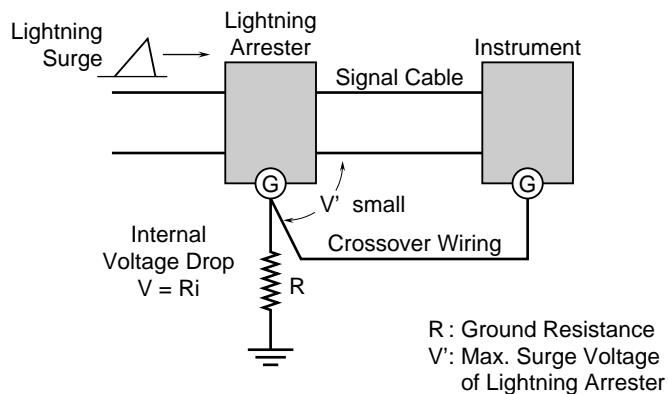

QUESTION
 10

Is an instrument safe if the lightning arrester on the power supply line is damaged?

ANSWER

Yes, because the lightning arresters have internal protection circuits.

DISCUSSION

Impulse voltages from a lightning surge can damage a discharge element. After this damage occurs, the current continues to flow once the voltage has fallen below the maximum levels. Each arrester has a protection circuit for this specific situation.

• MA-100, MA-200

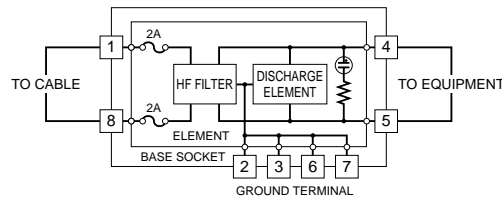

• MAX-100, MAX-200

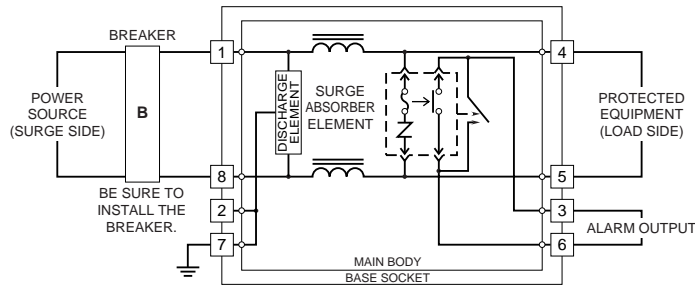

• MMA-100, MMA-200

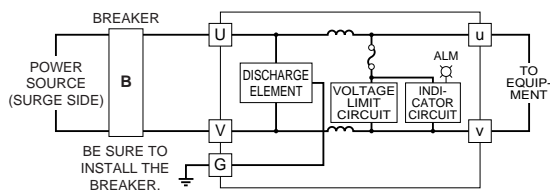

• MH-105A, MH-110A, MH-130A

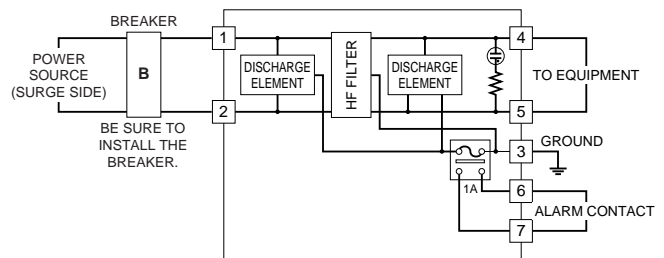

QUESTION
Q11

A field transmitter was connected to a lightning arrester, but it was still damaged by a lightning strike. Can you tell me why?

ANSWER
A

The lightning arrester that was selected could be incorrect for that specific application.

DISCUSSION

The maximum surge voltage of a lightning arrester to be used should be below the withstand voltage of the instrument(s) to be protected. This voltage level could be passed through the arrester to the instrument(s) during a lightning surge. Be sure to confirm this specification before selecting the arrester. Damage to protected equipment may occur because of this variable.

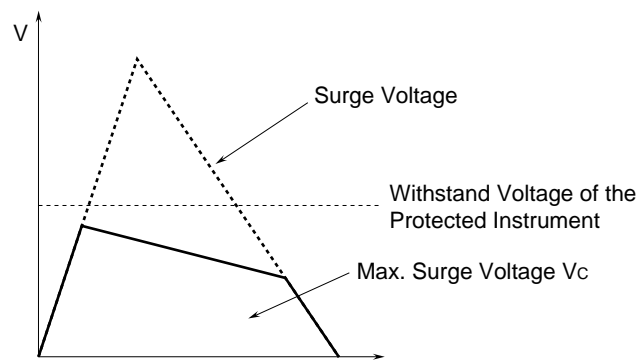

QUESTION
Q12

After a lightning storm, there was no input from the remote RTD sensor to the temperature transmitter. There is no detectable damage to the transmitter. What could have happened?

ANSWER
A

It seems that the RTD temperature sensor was the only device damaged by the lightning surge.

DISCUSSION

It is recommended that a lightning arrester be installed to protect the RTD sensor. If not, then the temperature transmitter's output signal could go upscale or downscale if this sensor is destroyed by a lightning surge. This means excessive down time for the process that is being monitored and controlled.

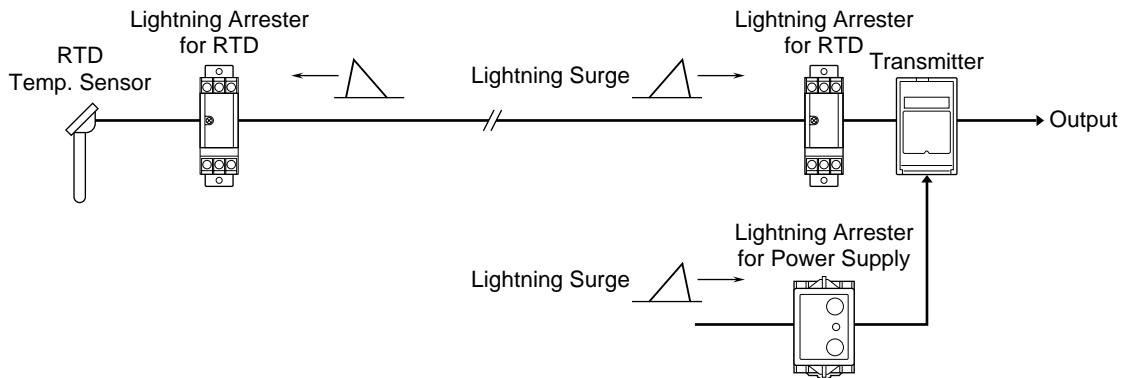

3. Connection Examples

■ THERMOCOUPLE

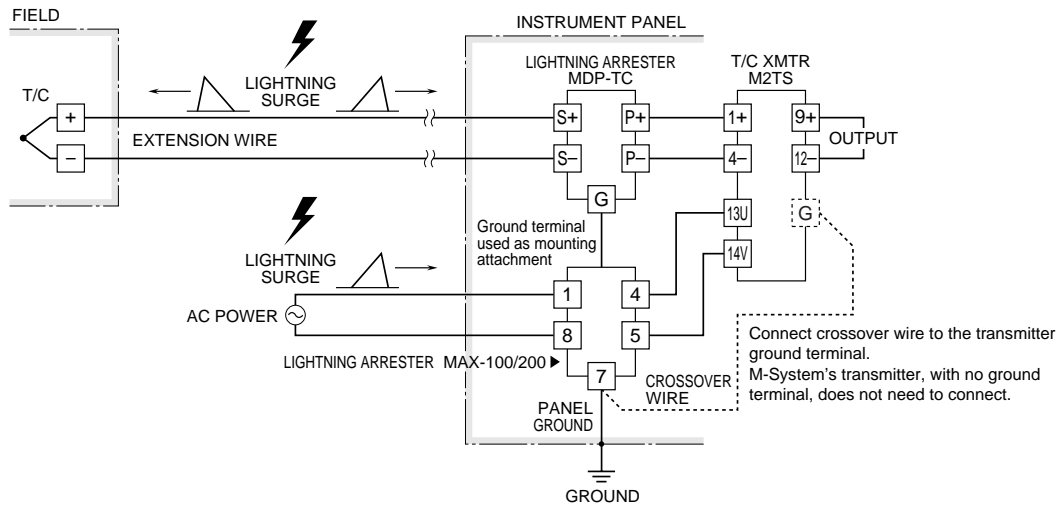

■ RTD

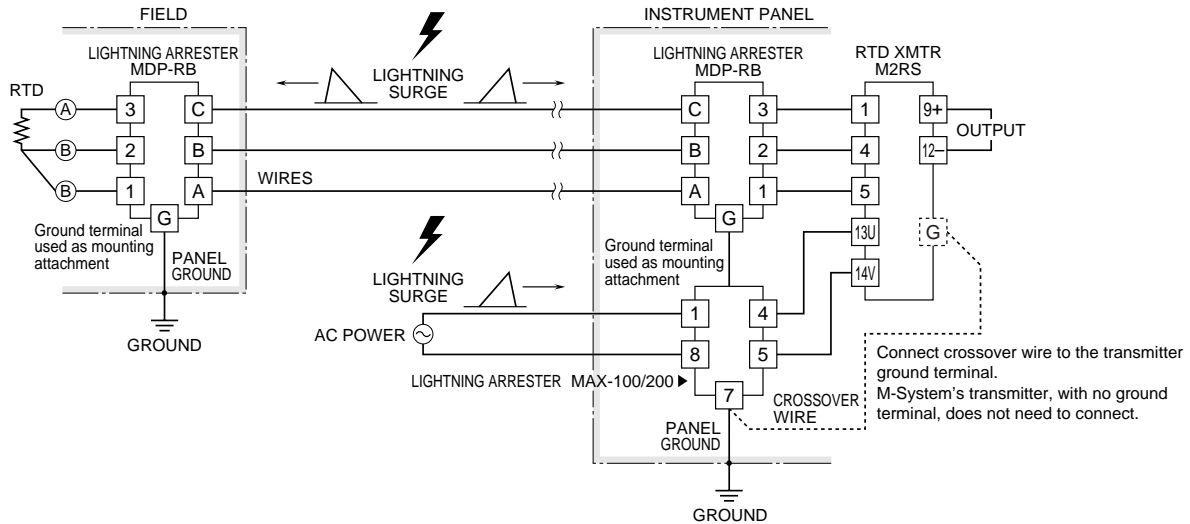

■ 2-WIRE TRANSMITTER

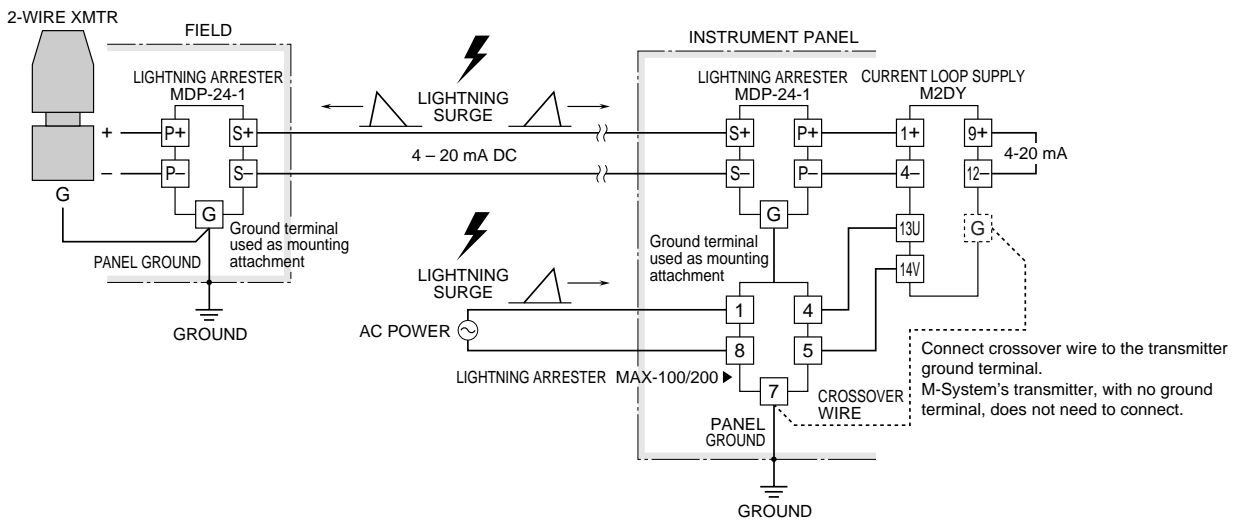

■ ELECTRO-MAGNETIC FLOWMETER

• Transmitter - converter separated

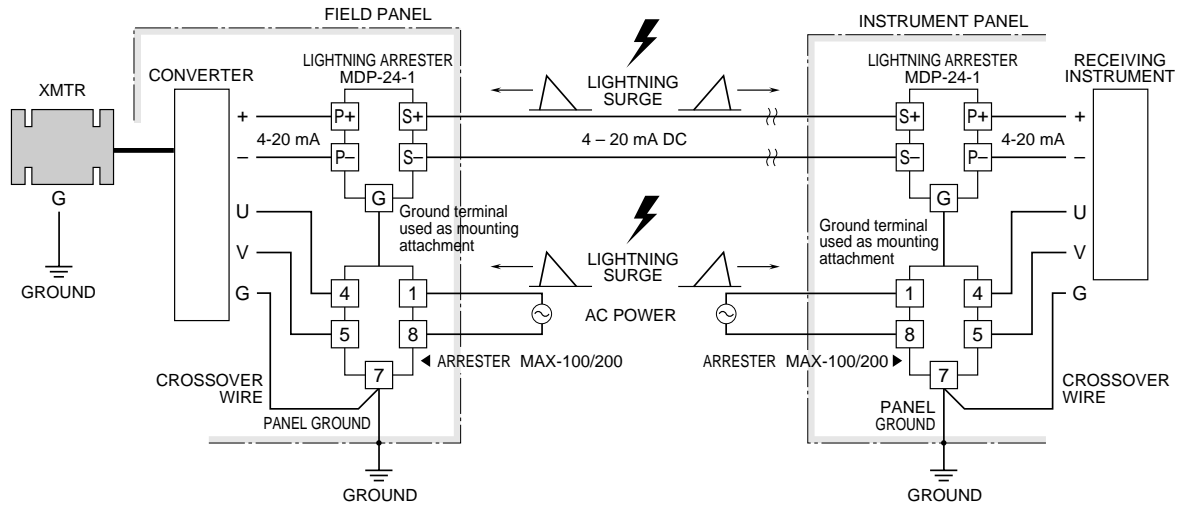

• Transmitter - converter combined

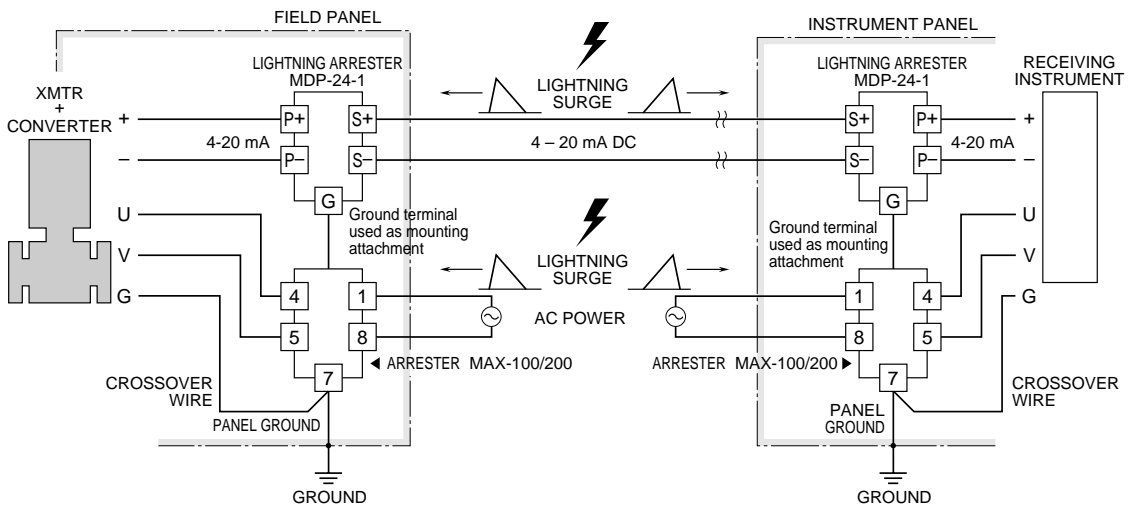

M-SYSTEM WARRANTY

1. What is covered.

M-System Co., Ltd. ("M-System") warrants, to the original purchaser only of new M-System products purchased directly from M-System, or from M-System's authorized distributors or resellers, for its own use not for resale, that the M-System products shall be free from defects in materials and workmanship and shall conform to the specifications set forth in the product catalogue applicable to the M-System products for the Warranty Period (see Paragraph 5 below for the Warranty Period of each product).

THE ABOVE WARRANTY IS THE ONLY WARRANTY APPLICABLE TO THE M-SYSTEM PRODUCTS AND IS IN LIEU OF ALL OTHER WARRANTIES, EXPRESS OR IMPLIED, INCLUDING, BUT NOT LIMITED TO, ALL IMPLIED WARRANTIES OF MERCHANTABILITY OR OF FITNESS FOR A PARTICULAR PURPOSE.

2. What is not covered.

This warranty does not cover any M-System product which has been: (1) modified, altered or subjected to abuse, misuse, negligence or accident; (2) improperly installed or installed in conjunction with any equipment for which it was not designed; or (3) damaged or destroyed by disasters such as fire, flood, lightning or earthquake.

In no event shall M-System be liable for any special, incidental, consequential or other damages, costs or expenses (including, but not limited to, loss of time, loss of profits, inconvenience or loss of use of any equipment).

3. Remedies.

If a defective product is returned to M-System in accordance with the procedures described below, M-System will, at its sole option and expense, either: (1) repair the defective product; (2) replace the defective product; or (3) refund the purchase price for the defective product paid by the purchaser. Except as otherwise provided by applicable state law, these remedies constitute the purchaser's **sole and exclusive** remedies and M-System's sole and exclusive obligation under this warranty.

4. Warranty Procedure.

If the purchaser discovers a failure of the M-System products to conform to the terms of this warranty within the Warranty Period, the purchaser must promptly (and, in any event not more than 30 days after the discovery of such failure) notify the relevant party as described below either by telephone or in writing at the below address to obtain an Authorized Return (AR) number and return the defective product to the relevant party. The designated AR number should be marked on the outside of the return package and on all correspondence related to the defective product. The purchaser shall return, at purchaser's expense, defective products only upon receiving an AR number. In order to avoid processing delays, please be sure to include: copies of the original purchase order and sales invoice; the purchaser's name, address and phone number; the model and serial numbers of the returned product; and a detailed description of the alleged defect.

5. Warranty Period.

Signal Conditioner:	36 months from the date of purchase.
M-Rester:	12 months from the date of purchase.
Valve Actuator:	18 months from the date of shipment from M-System or 12 months from the date of its installation, whichever comes first.
Other Products:	36 months from the date of purchase.

From the United States of America, Canada and Mexico:

M-SYSTEM TECHNOLOGY, INC.
16837 Addison Road, Suite 100
Addison, TX 75001
Phone: (972) 380-0292

From all other countries:

M-SYSTEM CO., LTD.
5-2-55, Minamitsumori, Nishinari-ku,
Osaka 557-0063 JAPAN
Phone: (06) 6659-8201

 **M·SYSTEM CO., LTD.**

5-2-55, Minamitsumori, Nishinari-ku, Osaka 557-0063 JAPAN
Tel: (06)6659-8201 Fax: (06)6659-8510

U. S. A. / CANADA / MEXICO

 **M·SYSTEM
TECHNOLOGY, INC.**

16837 Addison Road Suite 100, Addison, TX 75001
Tel: (972)380-0292 Fax: (972)380-1862
Toll Free: 800-544-3181