

Plug-in Signal Conditioners M-UNIT

CT ALARM
(dual or quad alarm trip; field-configurable)

MODEL **AS4CT**

MODEL & SUFFIX CODE SELECTION

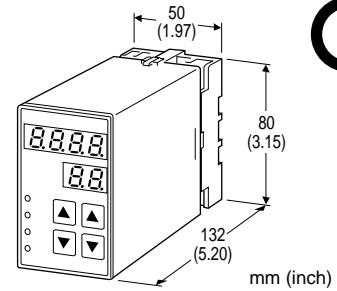
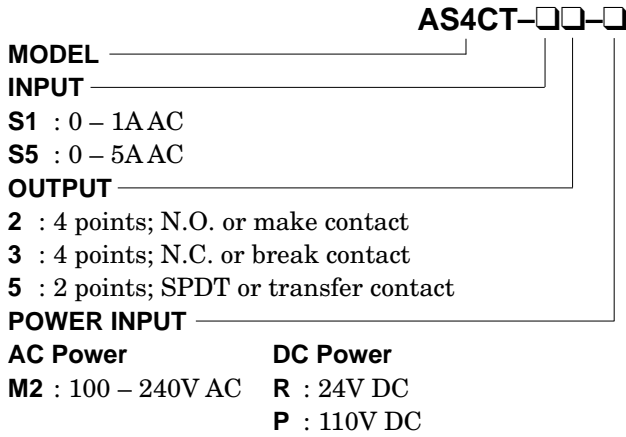

Functions & Features

- Providing relay outputs at preset AC current levels from a CT
- True RMS sensing
- Quad or dual trip
- Setting and display in engineering unit values
- Setpoint adjustments with the front keypad
- Software lock
- Adjustable hysteresis (deadband)
- On-delay timer
- Hi/Lo trip and energized/de-energized coil independently selectable for each setpoint
- CT Protector provided for open-circuit protection
- Enclosed relays
- Relays can be powered by 200V AC and 100V DC
- High-density mounting on DIN rail

Typical Applications

- Annunciator
- Various alarm applications

ORDERING INFORMATION

Specify code number. (e.g. AS4CT-S52-M2)

GENERAL SPECIFICATIONS

Construction: plug-in

Connection: M3.5 screw terminals

Housing material: flame-resistant resin (black)

Isolation: input to output to power

Input waveform: up to 15% of 3rd harmonic content

Setpoint adjustments: front key pad

Sampling cycle: 100 millisecc.

■DISPLAY

LED: 8 mm (.31") 7 segment, red

Number of display digits: 4 digits for DATA display;
2 digits for ITEM display

Range: -1999 to 9999
(decimal point position selectable)

PV indication: input signal in engineering unit

Overrange indication: LEDs flashing

Power saving mode: displays turn off if the keys are
untouched for a preset time period

LEDs: red lights turn on in tripped conditions

INPUT & OUTPUT

■ **INPUT:** 0 – 1A AC or 0 – 5A AC

Frequency: 50 or 60 Hz

Input burden: 0.5VA maximum

Overload capacity: 1000% of rating for 3 sec., 200% for 10 sec., 120% continuous

Operational range: 0 – 115% of rating

■ **OUTPUT**

Alarm Trip Operation Example with quad N.O. contacts (LL, L, H, HH); Terminal No. in parentheses

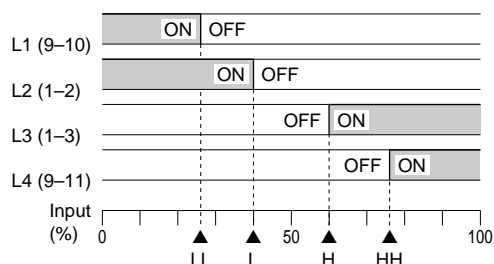
**Trip Operation in Power Failure**

- **Output Code 2:** all relays turn OFF.
- **Output Code 3:** all relays turn ON.
- **Output Code 5:** Terminals 1 – 3, 9 – 11 turn ON.

- **Relay Contact:** 120V AC @1A ($\cos\phi=1$)*
240V AC @0.5A ($\cos\phi=1$)*
30V DC @1A (resistive load)*
electrical life 10^5 cycles (rate 30/min.)

Maximum switching voltage: 380V AC or 125V DC

Maximum switching power: 100VA or 30W*

Minimum load: 5V DC @10mA

Mechanical life: 5×10^7 cycles

*Limited within 0.5A for CE.

INSTALLATION**Power input**

AC: operational voltage range 85 – 264V;
47 – 66 Hz, approx. 7VA

DC: operational voltage range for R: 24V $\pm 10\%$
or P: 85 – 150V;
approx. 3.5W (ripple 10% p-p max.)

Operating temperature: -5 to +55°C (23 to 131°F)

Operating humidity: 30 to 90% RH (non-condensing)

Mounting: surface or DIN rail

Dimensions: W50×H80×D132 mm (1.97"×3.15"×5.20")

See General Spec. Sheet Figure C-2.

Weight: 500 g (1.1 lbs)

Terminal assignment: See General Spec. Sheet Figure D-3.

PERFORMANCE in percentage of FS input

Setpoint accuracy (trip point accuracy):

$\pm(0.3\% \text{ of FS} + 1 \text{ digit})$

Display accuracy: $\pm(0.3\% \text{ of FS} + 1 \text{ digit})$

Temp. coefficient: $\pm 0.015\%/^{\circ}\text{C}$ ($\pm 0.008\%/^{\circ}\text{F}$)

Response time: ≤ 0.7 seconds (0 – 100% at 90% setpoint)

Line voltage effect: $\pm 0.1\%$ over voltage range

Insulation resistance: $\geq 100\text{M}\Omega$ with 500V DC

Dielectric strength: 2000V AC @1 minute

(input to output to power to ground)

STANDARDS & APPROVALS

CE conformity: EMC Directive (89/336/EEC)

EMI EN61000-6-4

EMS EN61000-6-2

Low Voltage Directive (73/23/EEC)

Installation category II

Pollution degree 2

Max. operating voltage 300V

Input to output to power – Basic insulation

SCHEMATIC CIRCUITRY & CONNECTION DIAGRAM

■ OUTPUT SUFFIX CODE: 2

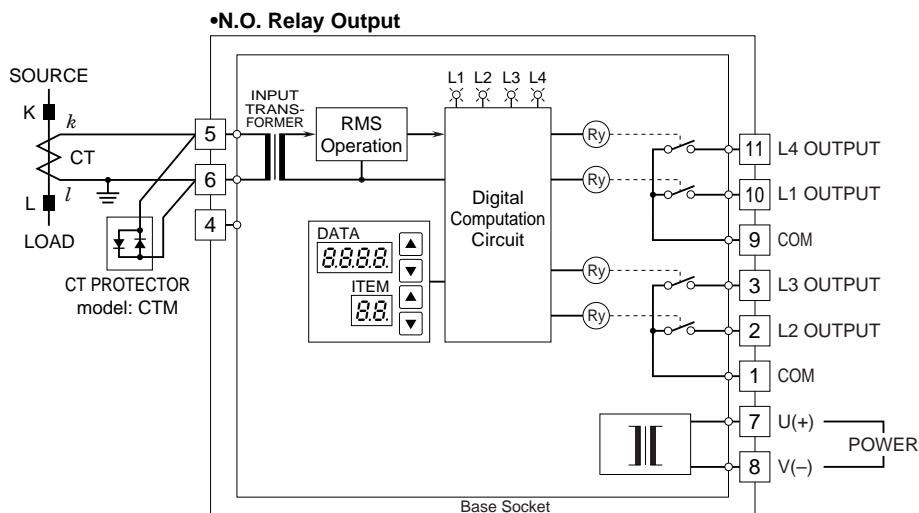

■ OUTPUT SUFFIX CODE: 3

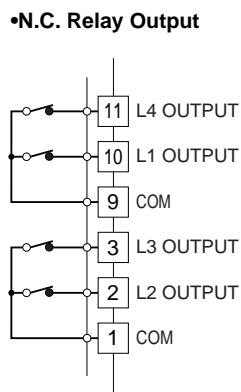

■ OUTPUT SUFFIX CODE: 5

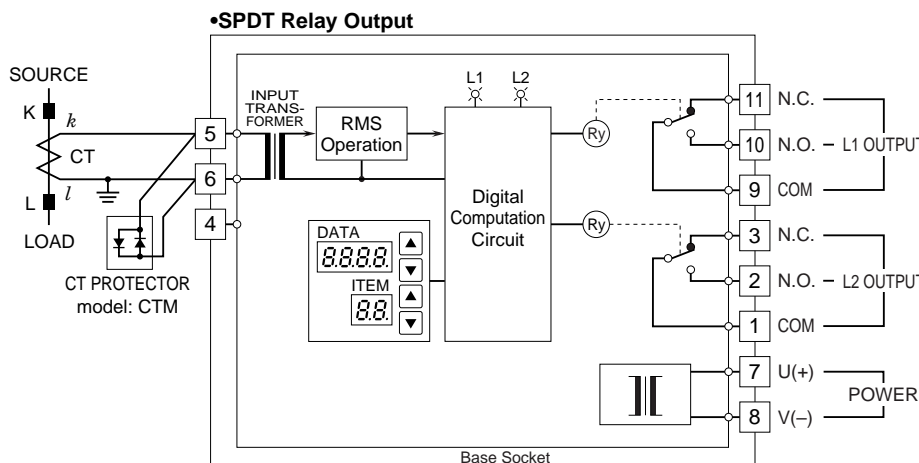

■ Relay Protection

•AC Powered

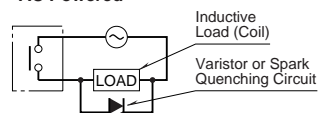

•DC Powered

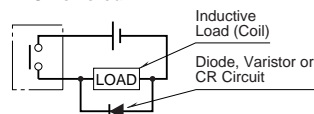

FRONT PANEL CONFIGURATION & PROGRAMMING

PROGRAMMING PROCEDURE

1. Press ITEM UP or DOWN key until ITEM display indicates "01".
2. Press DATA UP or DOWN key and choose "1" or "2" on DATA display.
 - 1 : Only alarm setpoints are modifiable.
 - 2 : All parameters are modifiable.
3. Press ITEM UP or DOWN key until ITEM display shows the ITEM No. you need to change.
4. Press DATA UP or DOWN key and choose a DATA No. or value you need on DATA display.
5. Repeat above 3 and 4. (Entered data is stored when you move to a new ITEM.)
6. Press ITEM UP or DOWN key until ITEM display indicates "01".
7. Press DATA UP or DOWN key and choose "0" on the display.
8. Press ITEM UP or DOWN key until ITEM display indicates "P". DATA display shows process input. You can now check data setting by choosing ITEM No.

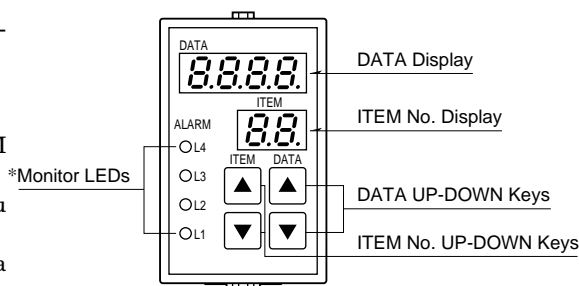

*L3 or L4 does not turn on for dual output type.

Note : DO NOT press UP and DOWN keys simultaneously.

ITEM	MDF. CODE	DATA	CONTENTS	DEFAULT SETTING
P	N/A	-1999 – 9999	Process input display in engineering unit (as set in ITEM 07/08)	—
L1	1, 2	-1999 – 9999	L1 alarm setpoint in engineering unit	Quad: 20.0 Dual: 20.0
L2	1, 2	-1999 – 9999	L2 alarm setpoint in engineering unit	Quad: 30.0 Dual: 80.0
L3	1, 2	-1999 – 9999	L3 alarm setpoint in engineering unit *1	Quad: 70.0
L4	1, 2	-1999 – 9999	L4 alarm setpoint in engineering unit *1	Quad: 80.0
01		0, 1, 2	Modification code 0 : Data indication only. 1 : Only ITEM L1 – L4 are modifiable. 2 : All parameters are modifiable.	1
02	N/A	0 – 99	Status indication ("0" is normally indicated.) 0: Normal 1: Memory error 10: Out of input range -15 – 115%	
03	N/A	6, 7	Input range 6: S1, 7: S5	Specified when ordering
04	N/A	-15.0 – 115.0	Input indicated in % (as set in ITEM 27, 28)	—
05	2	-19.99 – 99.99	Zero adjustment (%) (fine adj. of the value set in ITEM 27)	0.00
06	2	0.000 – 9.999	Gain adjustment (fine adj. of the value set in ITEM 28)	1.000
07	2	-1999 – 9999	Display range scaling 0% *2	0.0
08	2	-1999 – 9999	Display range scaling 100% *2	100.0
09	2	0, 1, 2, 3	Decimal point position 0 : _ _ _ _ (Specify the number of 1 : _ _ . _ _ digits 2 : _ . _ _ _ 3 : _ . _ _ _	1
10	2	0 – 99	Power ON-delay time (seconds)	5
11	2	0 – 99	Alarm ON-delay time (seconds)	0
12	2	0, 1, 2, 3, 4	Moving average (sampling cycle: 100 msec.) 0: No, 1: 4 samples, 2: 8 samples, 3: 16 samples, 4: 32 samples	0
13	2	0, 1	L1 trip operation (0 : Lo, 1: Hi)	Quad: 0 Dual: 0
14	2	0, 1	L2 trip operation (0 : Lo, 1: Hi)	Quad: 0 Dual: 1
15	2	0, 1	L3 trip operation (0 : Lo, 1: Hi) *1	Quad: 1
16	2	0, 1	L4 trip operation (0 : Lo, 1: Hi) *1	Quad: 1
17	2	0, 1 – 60	Power-saving mode 0: Continuous display 1 – 60: Time before display turned off (minutes)	10
18	2	0, 1	L1 coil at alarm (0: Energized, 1: De-energized)	0
19	2	0, 1	L2 coil at alarm (0: Energized, 1: De-energized)	0
20	2	0, 1	L3 coil at alarm (0: Energized, 1: De-energized) *1	0
21	2	0, 1	L4 coil at alarm (0: Energized, 1: De-energized) *1	0
22	N/A	—	Version No. indication	—
23	2	1 – 9999	L1 hysteresis (deadband) in engineering unit	1.0
24	2	1 – 9999	L2 hysteresis (deadband) in engineering unit	1.0
25	2	1 – 9999	L3 hysteresis (deadband) in engineering unit	1.0
26	2	1 – 9999	L4 hysteresis (deadband) in engineering unit	1.0
27	2	S5: 0.00 – 5.00*3	0% input voltage/current (ITEM 27 < ITEM 28)	S1: 0.00A, S5: 0.00A
28	2	S5: 0.00 – 5.00*3	100% input voltage/current (ITEM 27 < ITEM 28)	S1: 1.00A, S5: 5.00A

*1: Quad alarm trip type only

*2: Of the range set in ITEM 05/06. ITEM 07 < ITEM 08.

*3: S1: 0.00 – 1.00

Specifications subject to change without notice.