

Power Transducer Series *LT-UNIT*

VAR TRANSDUCER

MODEL LTRP

MODEL & SUFFIX CODE SELECTION

LTRP-□□□□□□□□

MODEL

CONFIGURATION

1 : 3-phase / 3-wire

4 : 3-phase / 4-wire

VT INPUT (balanced load)

1 : 100, 110, 115, 120V AC

2 : 190, 200, 210, 220, 230, 240V AC

4 : 380, 400, 415, 430, 440, 480V AC

For 3-phase/4-wire, phase voltages (e.g. $110V/\sqrt{3}$) are used.

CT INPUT (unbalanced load)

1 : 1A AC

2 : 2A AC

5 : 5A AC

OUTPUT SIGNAL POLARITY

P : Negative in lag, positive in lead

M : Negative in lead, positive in lag

OUTPUT

Current

A : 4 – 20mA DC

FW : -10 – +10mA DC

GW : -1 – +1mA DC

JW : -5 – +5mA DC

Z : Specify current

Voltage

6 : 1 – 5V DC

1W : -10 – +10mV DC

2W : -100 – +100mV DC

3W : -1 – +1V DC

4W : -10 – +10V DC

5W : -5 – +5V DC

0 : Specify voltage

AUXILIARY POWER SUPPLY

AC Power

K3: 100 – 120V AC

L3: 200 – 240V AC

DC Power

R : 24V DC

V : 48V DC

P : 110V DC *1

*1: CE marking unavailable

OPTIONS

/T : Terminal cover

How To Determine Var Range

$$\text{Calibration Range [var]} = \frac{\text{Measuring Range}}{(\text{VT Ratio}) \times (\text{CT Ratio})}$$

Check that the required calibration range is within the available range in the table. Specify this range when ordering.

[example]

3-phase / 3-wire, measuring range 75 kvar,

VT 220/110V, CT 250/5A

$$\frac{75 \times 10^3 \text{ [var]}}{(220/110) \times (250/5)} = 0 - 750 \text{ [var]}$$

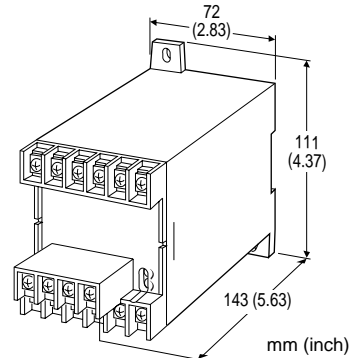

Functions & Features

- Providing a DC output signal in proportion to AC reactive power
- DC output containing little ripple is ideal for computer input
- "Time division multiplication" method accepts distorted waveforms
- Isolation up to 2000V AC
- High-density mounting
- Conforms to IEC 688

Typical Applications

- Centralized monitoring and control of power management system in a manufacturing facility or building

ORDERING INFORMATION

Specify code number and variables. Use Ordering Information Sheet (No. ESU-3355).

- Code number (e.g. LTRP-115PA-R)

GENERAL SPECIFICATIONS

Construction: stand-alone; terminal access at the front

Connection: M4 screw terminals

(chrome-plated steel; torque ≤ 1.2 N·m)

Housing material: flame-resistant resin (black)

Isolation: voltage input to current input to output to power

Computation: time division multiplication

Overrange output: approx. -10 – +120% at 1 – 5V

Front adjustments: zero and span; $\pm 5\%$

INPUT & OUTPUT

INPUT

Frequency: 50 or 60 Hz

Voltage Input

Operational range: 0 – 120% of rating

Overload capacity: 200% of rating for 10 sec.,
120% continuous

Current Input

Operational range: 0 – 120% of rating

Overload capacity: 4000% of rating for 1 sec., 2000%
for 4 sec., 120% continuous

INPUT RANGE

3-phase / 3-wire

INPUT		USABLE RANGE	BURDEN (VA)	
VT / CT CODE	STD. RANGE		VT	CT
1 / 1	200 var	100 – 240 var	0.2 /phase	0.5 /phase
1 / 2	400 var	200 – 480 var		
1 / 5	1000 var	500 – 1200 var		
2 / 1	400 var	200 – 480 var	0.4 /phase	
2 / 2	800 var	400 – 960 var		
2 / 5	2000 var	1000 – 2400 var		
4 / 1	800 var	400 – 960 var	0.6 /phase	
4 / 2	1600 var	800 – 1920 var		
4 / 5	4000 var	2000 – 4800 var		

3-phase / 4-wire

INPUT		USABLE RANGE	BURDEN (VA)	
VT / CT CODE	STD. RANGE		VT	CT
1 / 1	200 var	100 – 240 var	0.1 /phase	0.5 /phase
1 / 2	400 var	200 – 480 var		
1 / 5	1000 var	500 – 1200 var		
2 / 1	400 var	200 – 480 var	0.3 /phase	
2 / 2	800 var	400 – 960 var		
2 / 5	2000 var	1000 – 2400 var		
4 / 1	800 var	400 – 960 var	0.4 /phase	
4 / 2	1600 var	800 – 1920 var		
4 / 5	4000 var	2000 – 4800 var		

OUTPUT

•DC Current: -10 – +20mA DC

Span: min. 1mA, max. 20mA

Zero suppression/elevation: max. 1.5 times span

Load resistance: output drive 10V maximum

Output	Load Resistance
4 – 20mA	: 500 (Ω maximum)
-10 – +10mA	: 1000
-1 – +1mA	: 10k
-5 – +5mA	: 2000

•DC Voltage: -10 – +12V DC

Minimum span: 5mV

Zero suppression/elevation: max. 1.5 times span

Load resistance: output drive 1mA maximum at ≥0.5V

Output	Load Resistance
1 – 5V	: 5000 (Ω minimum)
-10 – +10mV	: 10k
-100 – +100mV	: 100k
-1 – +1V	: 1000
-10 – +10V	: 10k
-5 – +5V	: 5000

OPERATION DIAGRAM (example)

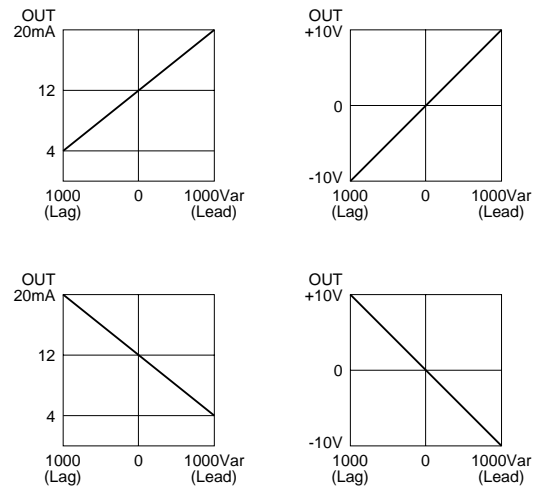

Specifications subject to change without notice.

INSTALLATION

Power input

AC: operational voltage range for K3: 85 – 132V or L3: 170 – 264V
47 – 66 Hz, approx. 2VA

DC: operational voltage range for R, V: rating $\pm 10\%$ or P: 85 – 150V; ripple 10% p-p max. approx. 2W (18mA at 110V)

Operating temperature: -10 to +55°C (14 to 131°F)

Operating humidity: 30 to 85% RH (non-condensing)

Mounting: surface or DIN rail

Dimensions: W72×H111×D143* mm (2.83"×4.37"×5.63")
*D147 mm (5.79") with terminal cover
See General Spec. Sheet Figure C-1.

Weight: 450 g (0.99 lbs)

Terminal assignment: See General Spec. Sheet Figure D-1.

PERFORMANCE in percentage of span

Accuracy: $\pm 0.5\%$ (at 23°C $\pm 10^\circ\text{C}$ or 73.4°F $\pm 18^\circ\text{F}$, 45 – 65 Hz)

Magnetic field (ext. origin) effect: $\pm 0.5\%$ (400A/m)

Response time: ≤ 2 seconds (0 – 100% $\pm 1\%$)

Ripple: 0.5% p-p max.**

Line voltage effect: $\pm 0.25\%$ over voltage range

Insulation resistance: $\geq 100\text{M}\Omega$ with 500V DC

Dielectric strength: 2000V AC @1 minute

(voltage input to current input to output to power to ground)

Impulse withstand voltage: 1.2/50 $\mu\text{sec.}$, $\pm 5\text{kV}$
(input to output or ground)

**The output ripple may increase when there is great difference between the frequencies of input signal and power supply.

STANDARDS & APPROVALS

CE conformity: Electromagnetic Compatibility Directive (89/336/EEC)

EMI EN50081-2

EMS EN50082-2 (EN61000-6-2)

Low Voltage Directive (73/23/EEC)

Installation category II

Pollution degree 2

Input to output or power – Reinforced insulation

Max. operating voltage 550V

Output to power – Reinforced insulation

Max. operating voltage 300V

IEC Standard: IEC 688

CONNECTION DIAGRAM

3-PHASE/3-WIRE

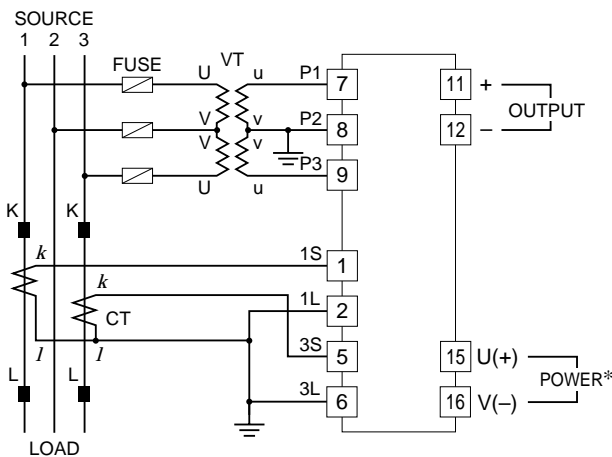

3-PHASE/4-WIRE

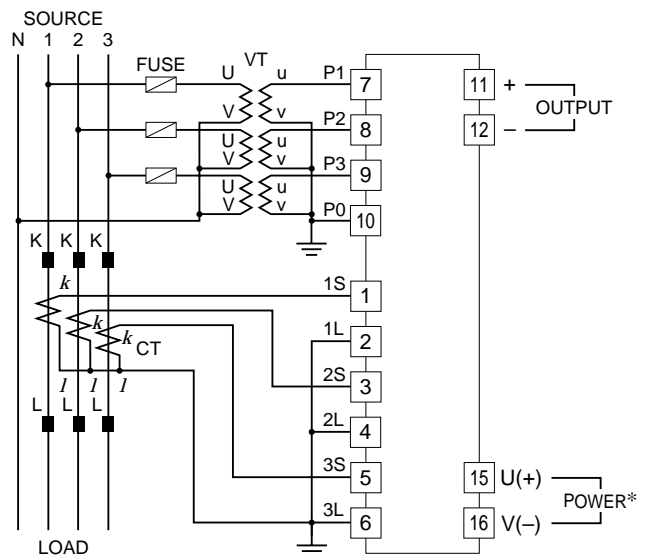

*The transducer can be powered from the input voltage when the voltage is sufficiently stable and meets within the range of auxiliary power supply of the unit specified in the data sheet/instruction manual.