

Power Transducer Series *LT-UNIT*

POWER FACTOR TRANSDUCER
(for unbalanced load; self-powered)

MODEL **LTPFUN**

MODEL & SUFFIX CODE SELECTION

LTPFUN-□□□□□□

MODEL _____

CONFIGURATION _____

1 : 3-phase / 3-wire

4 : 3-phase / 4-wire

VT INPUT (balanced load) _____

1 : 110V AC

2 : 220V AC

4 : $\frac{380V}{\sqrt{3}}$ / 380V AC (3-phase/4-wire only)

For 3-phase/4-wire, phase voltages (e.g. $110V/\sqrt{3}$) are used.

CT INPUT (unbalanced load) _____

1 : 1A AC

2 : 2A AC

5 : 5A AC

FREQUENCY _____

1 : 50 Hz

2 : 60 Hz

OUTPUT SIGNAL POLARITY _____

P : Negative in lag, positive in lead

M : Negative in lead, positive in lag

OUTPUT _____

Current	Voltage
A : 4 – 20mA DC	6 : 1 – 5V DC
FW : -10 – +10mA DC	1W : -10 – +10mV DC
GW : -1 – +1mA DC	2W : -100 – +100mV DC
JW : -5 – +5mA DC	3W : -1 – +1V DC
Z : Specify current	4W : -10 – +10V DC
	5W : -5 – +5V DC
	0 : Specify voltage

OPTIONS _____

/T : Terminal cover

ORDERING INFORMATION

Specify code number and variables. Use Ordering Information Sheet (No. ESU-3355).

- Code number (e.g. LTPFUN-1151PA/T)
- Special output range (For codes Z & 0)

GENERAL SPECIFICATIONS

Construction: stand-alone; terminal access at the front

Connection: M4 screw terminals
(chrome-plated steel; torque 1.2 N·m)

Housing material: flame-resistant resin (black)

Isolation: voltage input to current input to output

Computation: phase angle detection

Overrange output: approx. -10 – +120% at 1 – 5V

Front adjustments: zero and span; ±5%

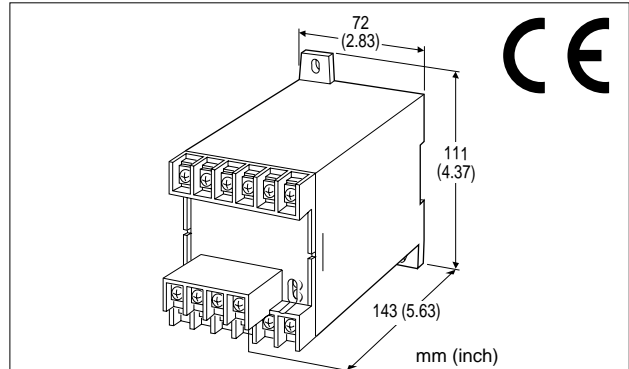

Functions & Features

- Providing a DC output signal in proportion to power factor
- Usable with unbalanced load
- DC output containing little ripple is ideal for computer input
- Isolation up to 2000V AC
- High-density mounting
- Conforms to IEC 60688
- No auxiliary power supply required

Typical Applications

- Centralized monitoring and control of power management system in a manufacturing facility or building
- Measuring power factor for a motor

INPUT & OUTPUT

■ INPUT

Remark: A device which employs different measuring methods may show different outputs from that of M-System's.

Frequency: 50 or 60 Hz

Input range: lag 0.5 – 1 – lead 0.5
lead 0.5 – 1 – lag 0.5

• Voltage Input

Operational range: 85 – 110% of rating

Overload capacity: 150% of rating for 10 sec.,
110% continuous

Input burden: 2.5VA

• Current Input

Operational range: 10 – 120% of rating

Overload capacity: 4000% of rating for 1 sec., 2000%
for 4 sec., 120% continuous

Input burden: 0.5VA

■ OUTPUT

• DC Current: -10 – +20mA DC

Span: min. 1mA, max. 20mA

Zero suppression/elevation: max. 1.5 times span

Load resistance: output drive 10V maximum

Output	Load Resistance
4 – 20mA	: 500 (Ω maximum)
-10 – +10mA	: 1000
-1 – +1mA	: 10k
-5 – +5mA	: 2000

•DC Voltage: -10 – +12V DC

Minimum span: 5mV

Zero suppression/elevation: max. 1.5 times span

Load resistance: output drive 1mA maximum at $\geq 0.5V$

Output	Load Resistance
1 – 5V	: 5000 (Ω minimum)
-10 – +10mV	: 10k
-100 – +100mV	: 100k
-1 – +1V	: 1000
-10 – +10V	: 10k
-5 – +5V	: 5000

■ OPERATION DIAGRAM (example)

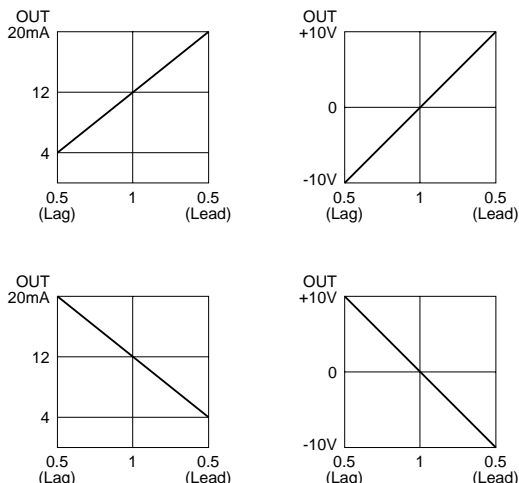

Remark: When there is no input voltage or 5% or less of rated input current, the transducer output equals approximately to '1'.

INSTALLATION

Operating temperature: -10 to +55°C (14 to 131°F)

Operating humidity: 30 to 85% RH (non-condensing)

Mounting: surface or DIN rail

Dimensions: W72×H111×D143 mm (2.83"×4.37"×5.63")
*D147 mm (5.79") with terminal cover

See General Spec. Sheet Figure C-1.

Weight: 450 g (0.99 lbs)

Terminal assignment: See General Spec. Sheet Figure D-1.

PERFORMANCE in percentage of span

Accuracy: $\pm 2\%$ with input 1 – 0.866, balanced load
 $\pm 4\%$ with input 0.866 – 0.5, balanced load
(at 23°C $\pm 10^\circ\text{C}$ or 73.4°F $\pm 18^\circ\text{F}$, at rated frequency $\pm 10\%$ [$\pm 5\%$ for 3-phase/4-wire])

Magnetic field (ext. origin) effect: $\pm 2\%$ (400A/m)

Response time: ≤ 2 seconds (0 – 100% $\pm 1\%$)

Ripple: 0.5% p-p max.

Insulation resistance: $\geq 100M\Omega$ with 500V DC

Dielectric strength: 2000V AC @1 minute

(voltage input to current input to output to ground)

Impulse withstand voltage: 1.2/50 $\mu\text{sec.}$, $\pm 5\text{kV}$

(input to output or ground)

STANDARDS & APPROVALS

CE conformity: Electromagnetic Compatibility Directive (89/336/EEC)

EMI EN61000-6-4

EMS EN61000-6-2

Low Voltage Directive (73/23/EEC)

Installation category II

Pollution degree 2

Input to output – Reinforced insulation

Max. operating voltage 300V

IEC Standard: IEC 60688

CONNECTION DIAGRAM

■ 3-PHASE/3-WIRE

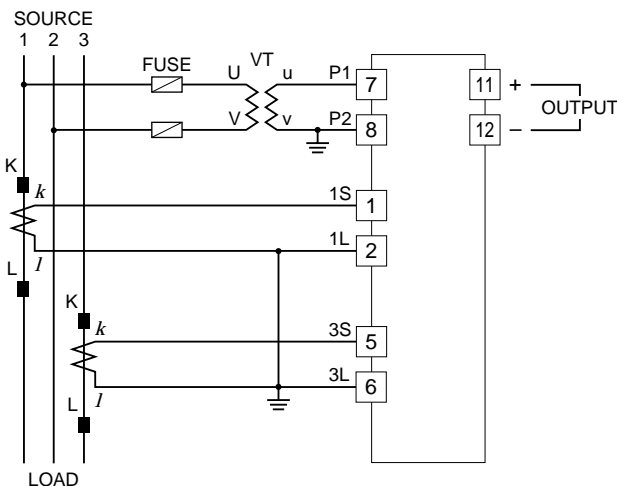

■ 3-PHASE/4-WIRE

