

**Power Transducer Series *LT-UNIT***

**POWER FACTOR TRANSDUCER**  
(for unbalanced load)

MODEL **LTPFU**

**MODEL & SUFFIX CODE SELECTION**

LTPFU-□□□□□□□□

MODEL

CONFIGURATION

1 : 3-phase / 3-wire

4 : 3-phase / 4-wire

VT INPUT (balanced load)

1 : 100, 110, 115, 120V AC

2 : 190, 200, 210, 220, 230, 240V AC

4 : 380, 400, 415, 430, 440, 480V AC

For 3-phase/4-wire, phase voltages (e.g.  $110V/\sqrt{3}$ ) are used.

CT INPUT (unbalanced load)

1 : 1A AC

2 : 2A AC

5 : 5A AC

FREQUENCY

1 : 50 Hz

2 : 60 Hz

OUTPUT SIGNAL POLARITY

P : Negative in lag, positive in lead

M : Negative in lead, positive in lag

OUTPUT

Current

A : 4 – 20mA DC

FW : -10 – +10mA DC

GW : -1 – +1mA DC

JW : -5 – +5mA DC

Z : Specify current

Voltage

6 : 1 – 5V DC

1W : -10 – +10mV DC

2W : -100 – +100mV DC

3W : -1 – +1V DC

4W : -10 – +10V DC

5W : -5 – +5V DC

0 : Specify voltage

AUXILIARY POWER SUPPLY

AC Power

K3 : 100 – 120V AC

L3 : 200 – 240V AC

DC Power

R : 24V DC

V : 48V DC

P : 110V DC\*

\*CE marking unavailable

OPTIONS

/T : Terminal cover

**ORDERING INFORMATION**

Specify code number and variables. Use Ordering Information Sheet (No. ESU-3355).

• **Code number** (e.g. LTPFU-1151PA-R)

• **Special output range** (For codes Z & 0)

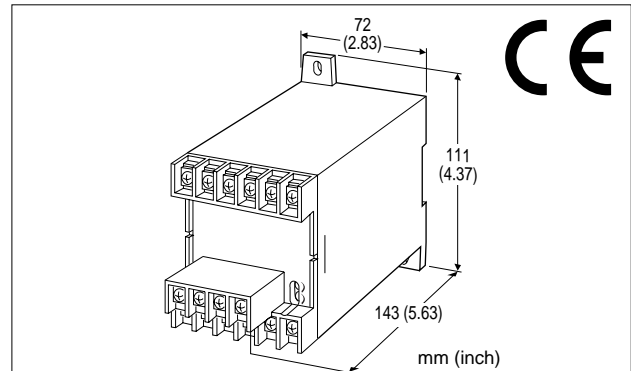

**Functions & Features**

- Providing a DC output signal in proportion to power factor
- Usable with unbalanced load
- DC output containing little ripple is ideal for computer input
- Isolation up to 2000V AC
- High-density mounting
- Conforms to IEC 60688

**Typical Applications**

- Centralized monitoring and control of power management system in a manufacturing facility or building
- Measuring power factor for a motor

**GENERAL SPECIFICATIONS**

**Construction:** stand-alone; terminal access at the front

**Connection:** M4 screw terminals

(chrome-plated steel; torque 1.2 N·m)

**Housing material:** flame-resistant resin (black)

**Isolation:** voltage input to current input to output to power

**Computation:** phase angle detection

**Overrange output:** approx. -10 – +120% at 1 – 5V

**Front adjustments:** zero and span; ±5%

**INPUT & OUTPUT**

**INPUT**

Remark: A device which employs different measuring methods may show different outputs from that of M-System's.

**Frequency:** 50 or 60 Hz

**Input range:** lag 0.5 – 1 – lead 0.5  
lead 0.5 – 1 – lag 0.5

• **Voltage Input**

**Operational range:** 85 – 120% of rating

**Overload capacity:** 150% of rating for 10 sec.,  
120% continuous

**Input burden:** 0.5VA

### •Current Input

**Operational range:** 10 – 120% of rating

**Overload capacity:** 4000% of rating for 1 sec., 2000%  
for 4 sec., 120% continuous

**Input burden:** 0.5VA

### ■OUTPUT

•DC Current: -10 – +20mA DC

**Span:** min. 1mA, max. 20mA

**Zero suppression/elevation:** max. 1.5 times span

**Load resistance:** output drive 10V maximum

Output	Load Resistance
4 – 20mA	: 500 ( $\Omega$ maximum)
-10 – +10mA	: 1000
-1 – +1mA	: 10k
-5 – +5mA	: 2000

•DC Voltage: -10 – +12V DC

**Minimum span:** 5mV

**Zero suppression/elevation:** max. 1.5 times span

**Load resistance:** output drive 1mA maximum at  $\geq 0.5V$

Output	Load Resistance
1 – 5V	: 5000 ( $\Omega$ minimum)
-10 – +10mV	: 10k
-100 – +100mV	: 100k
-1 – +1V	: 1000
-10 – +10V	: 10k
-5 – +5V	: 5000

### ■OPERATION DIAGRAM (example)

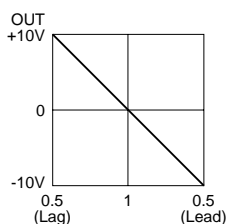
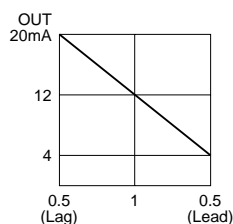
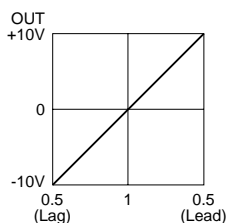
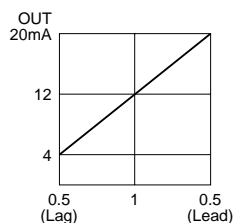

Remark: When there is no input voltage or 5% or less of rated input current, the transducer output equals approximately to '1'.

## INSTALLATION

### Power input

**AC:** operational voltage range for K3: 85 – 132V or L3: 170 – 264V  
47 – 66 Hz, approx. 2VA

**DC:** operational voltage range for R, V: rating  $\pm 10\%$  or P: 85 – 150V; ripple 10% p-p max.  
approx. 2W (18mA at 110V)

**Operating temperature:** -10 to +55°C (14 to 131°F)

**Operating humidity:** 30 to 85% RH (non-condensing)

**Mounting:** surface or DIN rail

**Dimensions:** W72×H111×D143 mm (2.83"×4.37"×5.63")  
\*D147 mm (5.79") with terminal cover  
See General Spec. Sheet Figure C-1.

**Weight:** 450 g (0.99 lbs)

**Terminal assignment:** See General Spec. Sheet Figure D-1.

## PERFORMANCE in percentage of span

**Accuracy:**  $\pm 2\%$  with input 1 – 0.866, balanced load  
 $\pm 4\%$  with input 0.866 – 0.5, balanced load  
(at 23°C  $\pm 10^\circ\text{C}$  or 73.4°F  $\pm 18^\circ\text{F}$ , at rated frequency  $\pm 10\%$  [ $\pm 5\%$  for 3-phase/4-wire])

**Magnetic field (ext. origin) effect:**  $\pm 2\%$  (400A/m)

**Response time:**  $\leq 2$  seconds (0 – 100%  $\pm 1\%$ )

**Ripple:** 0.5% p-p max.

**Line voltage effect:**  $\pm 1\%$  over voltage range

**Insulation resistance:**  $\geq 100M\Omega$  with 500V DC

**Dielectric strength:** 2000V AC @1 minute

(voltage input to current input to output  
to power to ground)

**Impulse withstand voltage:** 1.2/50  $\mu\text{sec.}$ ,  $\pm 5\text{kV}$   
(input to output or ground)

## STANDARDS & APPROVALS

**CE conformity:** Electromagnetic Compatibility  
Directive (89/336/EEC)

EMI EN61000-6-4

EMS EN61000-6-2

Low Voltage Directive (73/23/EEC)

Installation category II

Pollution degree 2

Input to output or power – Reinforced insulation

Max. operating voltage 550V

Output to power – Reinforced insulation

Max. operating voltage 300V

**IEC Standard:** IEC 60688

# CONNECTION DIAGRAM

## ■3-PHASE/3-WIRE

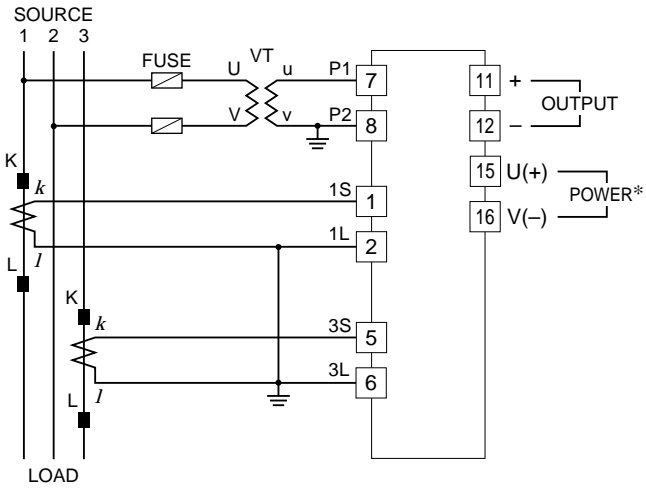

## ■3-PHASE/4-WIRE

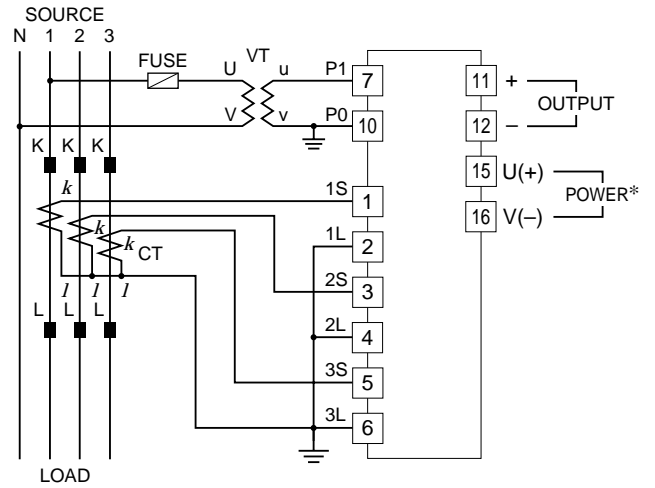

\*The transducer can be powered from the input voltage when the voltage is sufficiently stable and meets within the range of auxiliary power supply of the unit specified in the data sheet/instruction manual.