

Power Transducer Series *LT-UNIT*

PHASE ANGLE TRANSDUCER

MODEL **LTPA**

MODEL & SUFFIX CODE SELECTION

LTPA-□□□□□□□□

MODEL

CONFIGURATION

1 : 3-phase / 3-wire

4 : 3-phase / 4-wire

VT INPUT (balanced load)

1 : 100, 110, 115, 120V AC

2 : 190, 200, 210, 220, 230, 240V AC

4 : 380, 400, 415, 430, 440, 480V AC

For 3-phase/4-wire, phase voltages (e.g. $110V/\sqrt{3}$) are used.

CT INPUT (balanced load)

1 : 1A AC

2 : 2A AC

5 : 5A AC

OUTPUT SIGNAL POLARITY

P : Negative in lag, positive in lead

M : Negative in lead, positive in lag

OUTPUT

Current

A : 4 – 20mA DC

FW : -10 – +10mA DC

GW : -1 – +1mA DC

JW : -5 – +5mA DC

Z : Specify current

Voltage

6 : 1 – 5V DC

1W : -10 – +10mV DC

2W : -100 – +100mV DC

3W : -1 – +1V DC

4W : -10 – +10V DC

5W : -5 – +5V DC

0 : Specify voltage

AUXILIARY POWER SUPPLY

AC Power

K3: 100 – 120V AC

L3: 200 – 240V AC

DC Power

R : 24V DC

V : 48V DC

P : 110V DC*

*CE marking unavailable

OPTIONS

/T : Terminal cover

ORDERING INFORMATION

Specify code number and variables.

•Code number (e.g. LTPA-115PA-R)

•Special output range (For codes Z & 0)

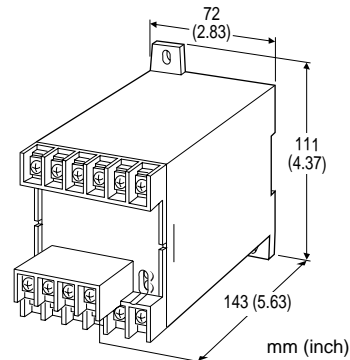

Functions & Features

- Providing a DC output signal in proportion to phase angle
- DC output containing little ripple is ideal for computer input
- Isolation up to 2000V AC
- High-density mounting
- Conforms to IEC 60688

Typical Applications

- Centralized monitoring and control of power management system in a manufacturing facility or building
- Measuring phase angle for a motor

GENERAL SPECIFICATIONS

Construction: stand-alone; terminal access at the front

Connection: M4 screw terminals

(chrome-plated steel; torque ≤ 1.2 N·m)

Housing material: flame-resistant resin (black)

Isolation: voltage input to current input to output to power

Computation: phase angle detection

Overrange output: approx. -10 – +120% at 1 – 5V

Front adjustments: zero and span; $\pm 5\%$

INPUT & OUTPUT

■INPUT

Frequency: 50 or 60 Hz

Input range: lag 60° – 0 – lead 60°

lead 60° – 0 – lag 60°

•Voltage Input

Operational range: 85 – 120% of rating

Overload capacity: 150% of rating for 10 sec., 120% continuous

Input burden: 0.5VA

•Current Input

Operational range: 10 – 120% of rating

Overload capacity: 4000% of rating for 1 sec., 2000% for 4 sec., 120% continuous

Input burden: 0.5VA

■ OUTPUT

• **DC Current:** -10 – +20mA DC

Span: min. 1mA, max. 20mA

Zero suppression/elevation: max. 1.5 times span

Load resistance: output drive 10V maximum

Output	Load Resistance
4 – 20mA	: 500 (Ω maximum)
-10 – +10mA	: 1000
-1 – +1mA	: 10k
-5 – +5mA	: 2000

• **DC Voltage:** -10 – +12V DC

Minimum span: 5mV

Zero suppression/elevation: max. 1.5 times span

Load resistance: output drive 1mA maximum at $\geq 0.5V$

Output	Load Resistance
1 – 5V	: 5000 (Ω minimum)
-10 – +10mV	: 10k
-100 – +100mV	: 100k
-1 – +1V	: 1000
-10 – +10V	: 10k
-5 – +5V	: 5000

■ OPERATION DIAGRAM (example)

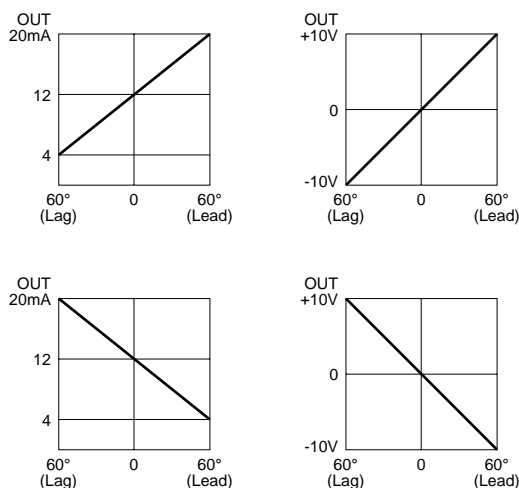

Remark: When there is no input voltage or 5% or less of rated input current, the output may become unstable (hunting).

INSTALLATION

Power input

AC: operational voltage range for K3: 85 – 132V or L3: 170 – 264V
47 – 66 Hz, approx. 2VA

DC: operational voltage range for R, V: rating $\pm 10\%$ or P: 85 – 150V; ripple 10% p-p max.
approx. 2W (18mA at 110V)

Operating temperature: -10 to +55°C (14 to 131°F)

Operating humidity: 30 to 85% RH (non-condensing)

Mounting: surface or DIN rail

Dimensions: W72×H111×D143 mm (2.83"×4.37"×5.63")

*D147 mm (5.79") with terminal cover

See General Spec. Sheet Figure C-1.

Weight: 450 g (0.99 lbs)

Terminal assignment: See General Spec. Sheet Figure D-1.

PERFORMANCE in percentage of span

Accuracy: $\pm 2\%$ with balanced load

(at 23°C $\pm 10^\circ\text{C}$ or 73.4°F $\pm 18^\circ\text{F}$, 45 – 65 Hz)

Magnetic field (ext. origin) effect: $\pm 2\%$ (400A/m)

Response time: ≤ 2 seconds (0 – 100% $\pm 1\%$)

Ripple: 0.5% p-p max.

Line voltage effect: $\pm 1\%$ over voltage range

Insulation resistance: $\geq 100M\Omega$ with 500V DC

Dielectric strength: 2000V AC @1 minute

(voltage input to current input to output to power to ground)

Impulse withstand voltage: 1.2/50 $\mu\text{sec.}$, $\pm 5\text{kV}$

(input to output or ground)

STANDARDS & APPROVALS

CE conformity: Electromagnetic Compatibility

Directive (89/336/EEC)

EMI EN50081-2

EMS EN50082-2 (EN61000-6-2)

Low Voltage Directive (73/23/EEC)

Installation category II

Pollution degree 2

Input to output or power – Reinforced insulation

Max. operating voltage 550V

Output to power – Reinforced insulation

Max. operating voltage 300V

IEC Standard: IEC 60688

CONNECTION DIAGRAM

■3-PHASE/3-WIRE

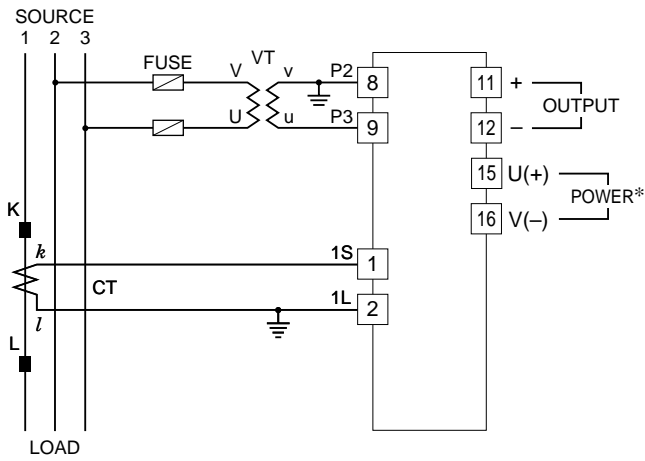

■3-PHASE/4-WIRE

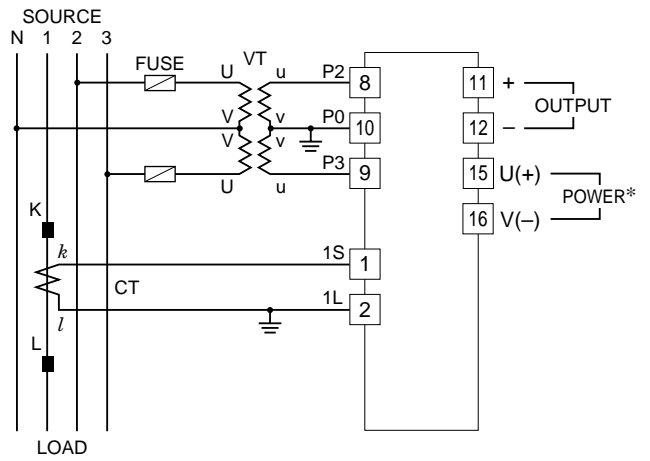

*The transducer can be powered from the input voltage when the voltage is sufficiently stable and meets within the range of auxiliary power supply of the unit specified in the data sheet/instruction manual.