

**Limit Alarms (rotary switch adj.) AL-UNIT**

**DC ALARM**

MODEL

**ALV**

**MODEL & SUFFIX CODE SELECTION**

ALV-□□□□

MODEL \_\_\_\_\_

INPUT \_\_\_\_\_

**Current**

**Voltage**

**A** : 4 – 20mA DC

**1** : 0 – 10mV DC

**A1** : 4 – 20mA DC\*

**15** : 0 – 50mV DC

**B** : 2 – 10mA DC

**16** : 0 – 60mV DC

**C** : 1 – 5mA DC

**2** : 0 – 100mV DC

**D** : 0 – 20mA DC

**3** : 0 – 1V DC

**E** : 0 – 16mA DC

**4** : 0 – 10V DC

**F** : 0 – 10mA DC

**5** : 0 – 5V DC

**G** : 0 – 1mA DC

**6** : 1 – 5V DC

**H** : 10 – 50mA DC

**4W** : -10 – +10V DC

**J** : 0 – 10µA DC

**5W** : -5 – +5V DC

**K** : 0 – 100µA DC

**0** : Specify voltage

**GW** : -1 – +1mA DC

**FW** : -10 – +10mA DC

**Z** : Specify current

\*50Ω input resistance for Code A1

**SETPOINT 1 OUTPUT**

**1** : Hi (coil energized at alarm)

**2** : Hi (coil de-energized at alarm)

**3** : Lo (coil energized at alarm)

**4** : Lo (coil de-energized at alarm)

**SETPOINT 2 OUTPUT**

**1** : Hi (coil energized at alarm)

**2** : Hi (coil de-energized at alarm)

**3** : Lo (coil energized at alarm)

**4** : Lo (coil de-energized at alarm)

**POWER INPUT**

**AC Power**

**DC Power**

**B** : 100V AC

**G** : 200V AC

**S** : 12V DC

**C** : 110V AC

**H** : 220V AC

**R** : 24V DC

**D** : 115V AC

**J** : 240V AC

**V** : 48V DC

**F** : 120V AC

**P** : 110V DC

**ORDERING INFORMATION**

Specify code number and variables.

• **Code number** (e.g. ALV-A13-B)

• **Special input range** (For codes Z & 0)

**GENERAL SPECIFICATIONS**

**Construction:** plug-in

**Connection:** M3.5 screw terminals

**Housing material:** flame-resistant resin (black)

**Isolation:** input to output to power

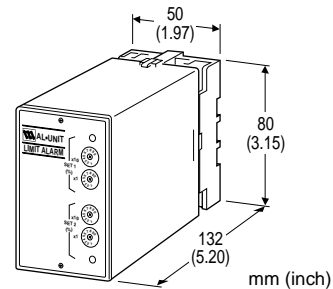

**Functions & Features**

- Providing SPDT relay outputs at preset DC input levels
- Dual (Hi/Lo) trip
- Energized or de-energized coil at a tripped condition selectable
- Rotary switch setpoint adjustments
- Enclosed relays
- Relays can be powered 110V DC
- Isolation up to 2000V AC
- High-density mounting

**Typical Applications**

- Annunciator
- Various alarm applications

**Setpoint adjustments:** 10-position rotary switches (front); 0 – 99% independently; 1% increments

**Hysteresis (deadband):** 0.7 – 2.5%

**Front LEDs:** red lights turn on when coils are energized.

**Power ON timer:** relays de-energized for approx. 2 seconds after power is turned on.

**INPUT & OUTPUT**

■ **INPUT**

• **DC Current:** shunt resistor attached to input terminals (0.5W)

**Input resistance:** For resistance values other than listed below, specify when ordering.

Input	Input Resistance
4 – 20mA	: 250 (Ω) (50Ω for Code A1)
2 – 10mA	: 500
1 – 5mA	: 1000
0 – 20mA	: 50
0 – 16mA	: 62.5
0 – 10mA	: 100
0 – 1mA	: 1000
10 – 50mA	: 100
0 – 10µA	: 1000
0 – 100µA	: 1000
-1 – +1mA	: 1000
-10 – +10mA	: 100

- DC Voltage: -300 – +300V DC
- Minimum span: 10mV
- Zero suppression/elevation: max. 1.5 times span
- Input resistance

Input Span	Input Resistance
10 – 100mV	: 10k (Ω minimum)
0.1 – 1V	: 100k
≥1V	: 1M

■OUTPUT

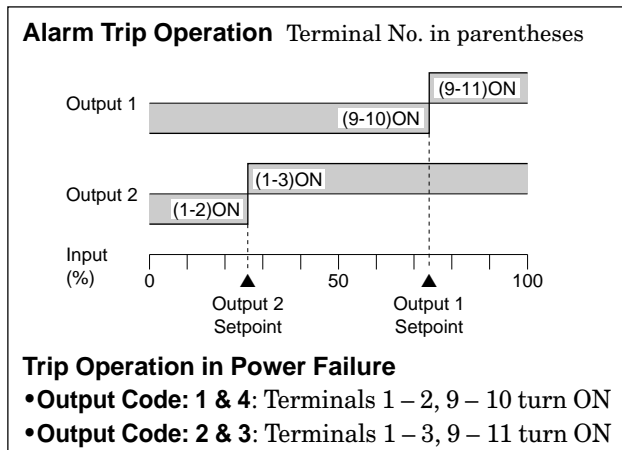

- Relay Contact: 120V AC @1A (cosφ=1)  
240V AC @0.5A (cosφ=1)  
30V DC @1A (resistive load)  
electrical life  $5 \times 10^5$  cycles (rate 30/min.)

Maximum switching voltage: 380V AC or 125V DC

Maximum switching power: 100VA or 30W

Minimum load: 5V DC @10mA

Mechanical life:  $5 \times 10^7$  cycles

For maximum relay life with inductive loads, external protection is recommended.

**INSTALLATION**

**Power input**

- AC: rating ±10%, 50/60 ±2 Hz, approx. 2VA
- DC: rating ±10%, or 85 – 150V for 110V rating (ripple 10% p-p max.)  
approx. 2W (80mA at 24V)

Operating temperature: -5 to +60°C (23 to 140°F)

Operating humidity: 30 to 90% RH (non-condensing)

Mounting: surface or DIN rail

Dimensions: W50×H80×D132 mm (1.97"×3.15"×5.20")

See General Spec. Sheet Figure A.

Weight: 370 g (0.82 lbs)

Terminal assignment: See General Spec. Sheet Figure B-2.

**PERFORMANCE in percentage of span**

Setpoint accuracy: ±0.5%

Trip point repeatability: ±0.05%

Temp. coefficient: ±0.015%/°C (±0.008%/°F)

Response time: approx. 0.5 sec. (0 – 100% at 90% setpoint)

Line voltage effect: ±0.1% over voltage range

Insulation resistance: ≥100MΩ with 500V DC

Dielectric strength: 2000V AC @1 minute (input to output 1 to output 2 to power to ground)

**FRONT PANEL CONFIGURATION**

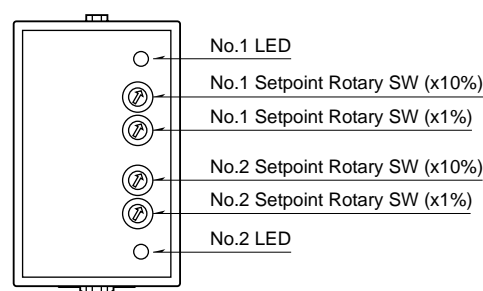

**SCHEMATIC CIRCUITRY & CONNECTION DIAGRAM**

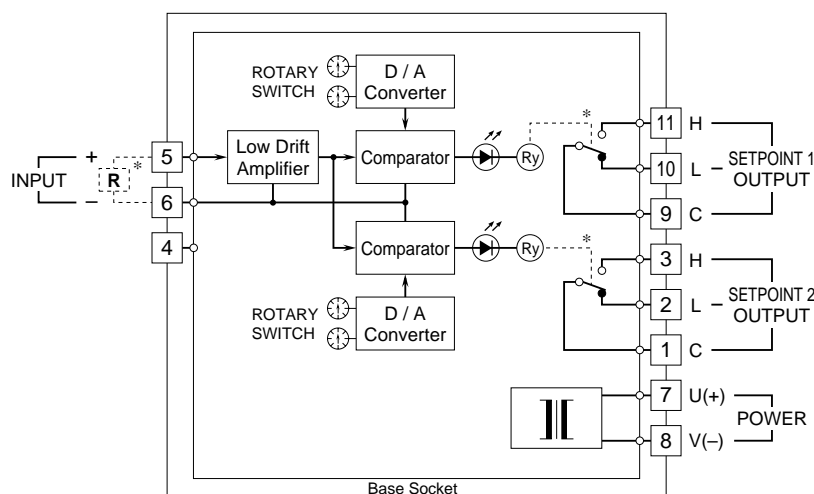

\* Input shunt resistor attached for current input.  
\*\*Relay status for output codes "1" & "4", at power OFF.

■Relay Protection

•AC Powered

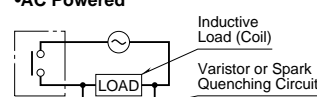

•DC Powered

