

IM-21 MOTORS W/OPTICAL ENCODER

DC Permanent Magnet Motors

E-2620



- power rating: To .1 hp (74.6 W)
- voltage: 12, 19.1, 24, 30.3 standard windings
- armature: Skewed for lower cogging torque
- inertia: See table, opposite page
- electrical time constant: 1.6 milliseconds max
- mechanical time constant: 10 milliseconds max
- typical no load torque: 2.0 oz. in.
- shaft: Precision-ground and hardened stainless steel.
Options: length, flats, pinions, gears
- terminals: Tab type with .230 min. terminal engagement to mate with Amp 187 series push-on receptacles, or equivalent
- magnets: High energy ceramic to withstand high pulse currents without demagnetizing
- bearings:
 - Ball: Pre-loaded to withstand higher side loads and low end play
- cover: Corrosion-protected steel housing
- end bells: Die-cast zinc
- winding insulation rating: 180°C
- winding temperature rise: ***See chart, opposite page
- options available:
 - EMI suppression

Dimensions

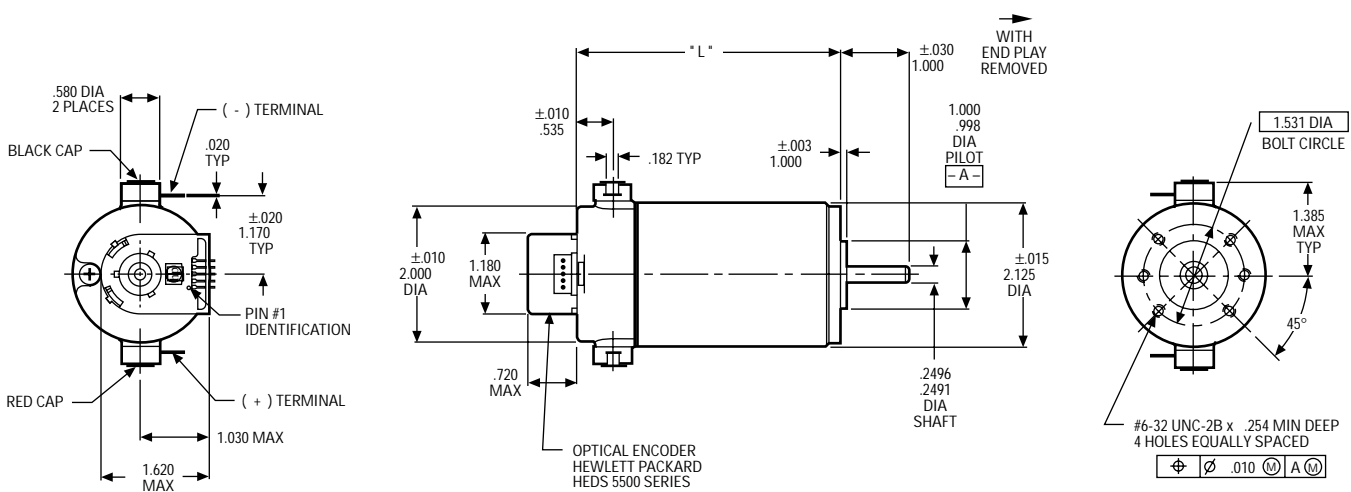

ROTATION (VIEWED FROM SHAFT END)
 CW - POSITIVE VOLTAGE TO (+) NEGATIVE VOLTAGE TO (-)
 CCW - REVERSE POLARITY

NOTE: Consult factory prior to preparing spec control prints. Dimensions are for reference only.

Standard Part Numbers and Data

VOLTAGE (VDC)	A		B		C			D			STANDARD PART NUMBERS*
	SPEED ±10% no load (rpm)	TORQUE (oz. in.) max rated	TORQUE (oz. in.) ** theoretical stall	CURRENT (amps) max no load	CURRENT (amps) max rated load	CURRENT (amps) ** nominal stall	TORQUE CONSTANT K_T (oz. in./amp)	TERMINAL RESISTANCE R (ohms)	INERTIA (oz. in. sec ²) x10 ⁻³	*** TEMP. RISE (°C/watt)	
Motor Length "L" Max. 3.203"											ball bearings
12.0	4200	15	95	.63	5.4	20.7	3.82	0.58	2.0	6.0	537A243-1
19.1				.41	3.5	16.5	5.88	1.16			-2
24.0				.32	2.7	12.8	7.56	1.87			-3
30.3				.26	2.4	10.3	9.45	2.95			-4
Motor Length "L" Max. 3.703"											
12.0	3700	20	140	.60	6.1	26.7	4.28	0.45	2.9	5.6	537A244-1
19.1				.38	3.9	21.2	6.76	0.90			-2
24.0				.30	3.1	16.7	8.60	1.44			-3
30.3				.23	2.4	13.0	11.06	2.34			-4
Motor Length "L" Max. 4.078"											
12.0	3750	24	190	.63	7.4	34.3	4.15	0.35	3.4	4.7	537A245-1
19.1				.39	4.5	27.7	6.99	0.69			-2
24.0				.32	3.7	22.6	8.54	1.06			-3
30.3				.26	2.9	17.7	10.87	1.71			-4
Motor Length "L" Max. 4.453"											
12.0	3100	30	220	.56	7.5	35.3	5.18	0.34	4.1	4.3	537A246-1
19.1				.33	4.6	26.9	8.46	0.71			-2
24.0				.27	3.8	21.8	10.35	1.10			-3
30.3				.21	3.0	17.1	13.17	1.77			-4
Motor Length "L" Max. 4.953"											
12.0	3175	35	290	.47	8.8	46.2	5.15	0.26	5.0	4.0	537A247-1
19.1				.38	5.7	37.5	7.90	0.51			-2
24.0				.30	4.4	28.9	10.15	0.83			-3
30.3				.23	3.4	22.6	12.97	1.34			-4

** Because of brush drop and field distortion, current and torque indicated will not always be attainable

*** Winding temperature rise measured when mounted to 8.00" x .25" aluminum plate. Multiply by 1.4 when mounted to a heat insulator.

*When You Order

Units shown above are standard and may be ordered by part number. Remember to include armature winding dash number, EXAMPLE: 537A243-1

Typical Motor Performance

Part No.: 537A243-1

Voltage: 12 VDC

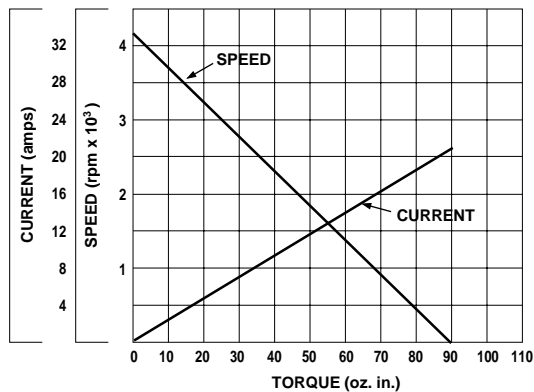

Part No.: 537A247-3

Voltage: 24 VDC

