

AC300/AC400 SERIES DYNAMIC BRAKING and ADDITIONAL FORM C RELAY

INSTALLATION INSTRUCTIONS

Document Number: 250-0296

These instructions apply to models rated:

- .5 – 5HP, 240/200 VAC
- 1 – 7.5 HP, 480/400 VAC
- 1– 7.5 HP, 590/480 VAC

1.0 GENERAL

These installation instructions apply to the Dynamic Braking and Additional Form C Relay options available for the AC300 and AC400 Series variable frequency drives. These components can also be ordered with the drive as factory installed options. Refer to the AC300 or AC400 Series Product Catalog for more information.

The exploded diagram (DIAGRAM A) in this document shows the Dynamic Braking Option Board for illustration purposes. The Additional Form C Relay Option Board is very similar, and the installation procedure is the same.

2.0 DYNAMIC BRAKING

The Dynamic Braking Option includes a resistor assembly that is mounted externally from the drive. The two wires (RED and BLUE) from the resistor assembly are connected to DB 1 and DB2 on the DB Board, as shown in the diagram below.

In order to activate the Dynamic Braking feature, Parameter 14 (DYN BRAKE) must be set to ON. Refer to the AC3000 Series Installation and Operation Manual for information on programming the drive.

3.0 ADDITIONAL FORM C RELAY

The Additional Form C Relay Board converts one of the two open collector outputs on the Main Control Board into a Form C relay output, resulting in two Form C relays and one open collector output being available for drive status indication. This is done by connecting the yellow wire from the Relay Board to terminal 14 on the Main Control Board, and then programming Parameter 52 (TB 14 OUT) for the desired indication. Refer to the AC300 or AC400 Installation and Operation Manual for information on programming the drive.

NOTE

For 240 VAC drives only: If the Dynamic Braking Kit was ordered separately from the drive, refer to DIAGRAM B for resistor assembly modifications. Resistor assemblies supplied with DB kits that are ordered separately are shipped in the 480 VAC and 590 VAC configuration and must be modified to operate with 240 VAC drives.

The Relay Board has a terminal block labeled 19, 20, and 21, which are the contacts of the Form C relay. The configuration is the same as the Form C relay at terminals 16, 17, and 18 on the Main Control Board, as shown below.

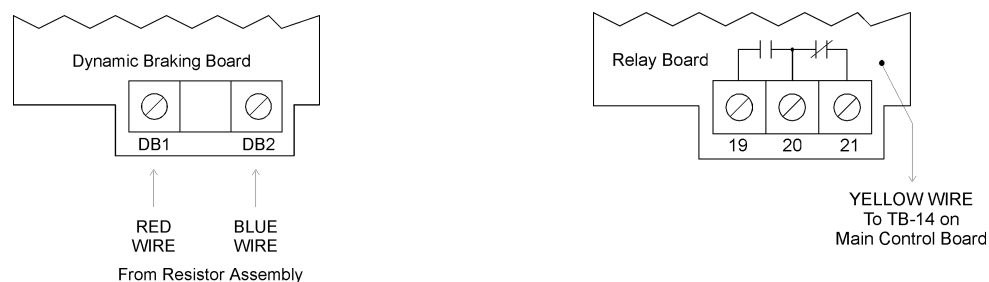

The following parts are included with the Dynamic Braking and Additional Form C Relay kits:

- | | |
|--|--------------------------------------|
| (1) Dynamic Braking Board (9935/XXX, or 9956/XXX)
or Additional Form C Relay Board (9934/XXX or 9956/XXX) | (1) 3/4" Nylon sleeve standoff |
| (1) 7/16" Nylon sleeve standoff | (1) Nylon shoulder washer |
| (2) Nylon "snap-in" standoff (7.5 HP, 480 VAC & 590 VAC kits only) | (1) Resistor assembly (DB kits only) |



Warning

Electric shock hazard! Remove input power from the drive and wait three minutes before attempting this procedure. DC Bus capacitors retain charge after power is removed.

The internal components of the AC300 and AC400 Series drive can be damaged by electrostatic discharge (ESD)! Use an antistatic wrist strap with the ground clip attached to the drive ground lug when attempting this procedure. Always place components on antistatic surfaces or in antistatic bags when they are not being handled during this procedure.

1. Remove the drive cover.
2. Remove the keypad assembly. On NEMA 1 units, this is done by prying one end of the bracket up and out. On NEMA 4 or 12 units, remove the screws that hold the bracket in place. Unplug the keypad ribbon cable from the Main Control Board (9933A-XXX). Use care not to bend any pins.
3. Remove the Main Control Board by removing the four screws (one at each corner). Lift the board straight up and out with care not to bend any pins. There are many pins connected to the board from underneath that are easily bent.

Remove the 1-5/16"-inch nylon sleeve standoff from the lower left-hand corner screw, and replace it with the 3/4" nylon sleeve standoff from the kit.

There is a 2 x 6 pin connector that connects the P3 plug on the Main Control Board to the P3 plug on the Power Board underneath. Leave this plugged into the P3 plug on the Power Board.

4. Under the Main Control Board is the Driver Board (9926-XXX), which needs to be removed to install the DB Board or Relay Board. Remove the Driver Board by pinching the flared top of each nylon standoff while gently lifting up on the board (leave the standoffs snapped into the Power Board underneath). Lift the Driver Board straight up and out with care not to bend any pins. There are many pins connected to the Driver Board from underneath that are easily bent.

NOTE: On 7.5 HP, 480 VAC & 590 VAC drives only, remove and save the 2 x 6 pin connector that is plugged into PL2 on the Driver Board (another 2 x 6 connector may be included in the DB kit; only one is needed).

5. Slide the nylon shoulder washer through the 3/16" hole near the lower left hand side of the DB Board or Relay Board. Slide the 7/16" nylon sleeve standoff onto the shoulder washer from the bottom side of the board (see diagram).

NOTE: On 9956-XXX Boards only (7.5 HP, 480 VAC & 590 VAC drives), install the two nylon "snap-in" standoffs into the holes at the bottom near the DB 1 and DB2 terminals.

6. Snap the DB Board or Relay Board into place where the old Driver Board was, using the same nylon standoffs that held the Driver Board in place. Make sure that the PL1 pin connector (and the P8 and P9 spade connectors on DB Boards) makes positive contact with their respective plugs. Be careful not to bend any pins.

NOTE 1: The 9956-XXX board (7.5 HP, 480 VAC & 590 VAC drives) also has a P11 connector on the bottom of the board. Make sure that the P11 connector makes positive contact to the pins on the Power Board underneath.

NOTE 2: On 9956-XXX boards only (7.5 HP, 480 VAC & 590 VAC drives), install the 2 x 6 pin connector in PL2.

7. Re-install the Main Control Board. Make sure that the PL2 and P3 pin connectors make positive contact through the bottom of the Main Control Board. Be careful not to bend any pins.
8. Re-install the keypad assembly and drive cover.

DIAGRAM A - EXPLODED VIEW

0.5 - 5 HP, 240/200 VAC
 1 - 1.75 HP, 480/400 VAC
 1 - 7.5 HP, 590/480 VAC

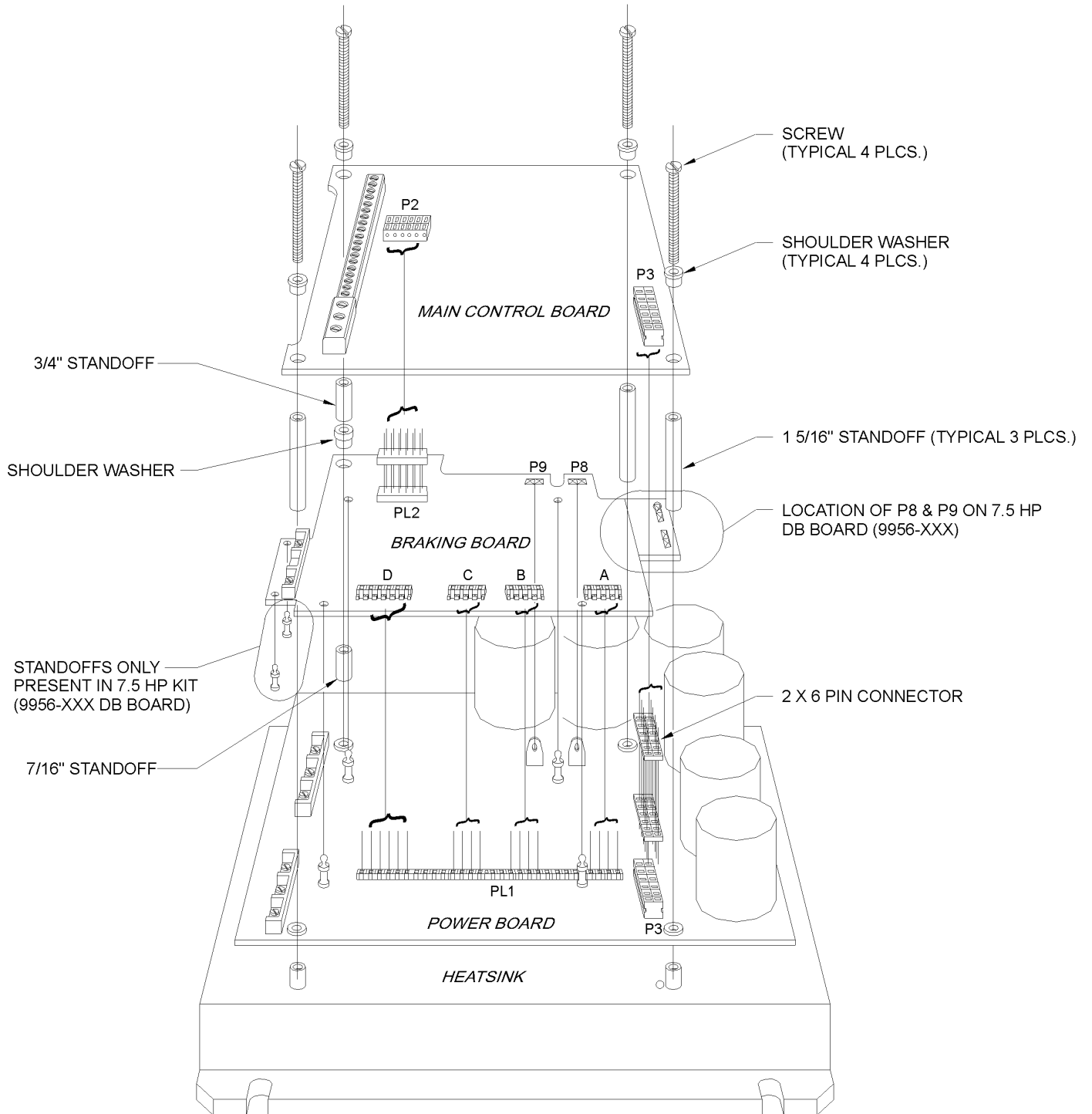
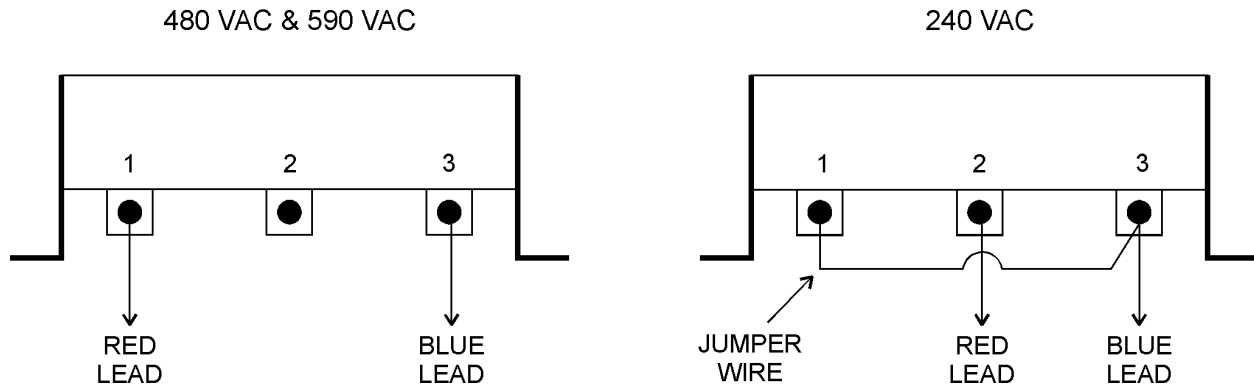

DIAGRAM B - RESISTOR CONFIGURATIONS

If the Dynamic Braking Kit is ordered separately from the AC300 or AC400 Series drive, the resistor assembly will be shipped in the 480 VAC and 590 VAC configuration. Therefore, for 240 VAC units, the resistor configuration must be modified as shown below, using the hardware included with the kit.

NOTE: If the Dynamic Braking option is ordered with the drive, the resistor assembly will be shipped in the proper configuration, and no modification is required.

0.5 - 5 HP



Add jumper wire between Tab #1 and Tab #3, and move the RED wire to Tab #2.

7.5 - 25 HP

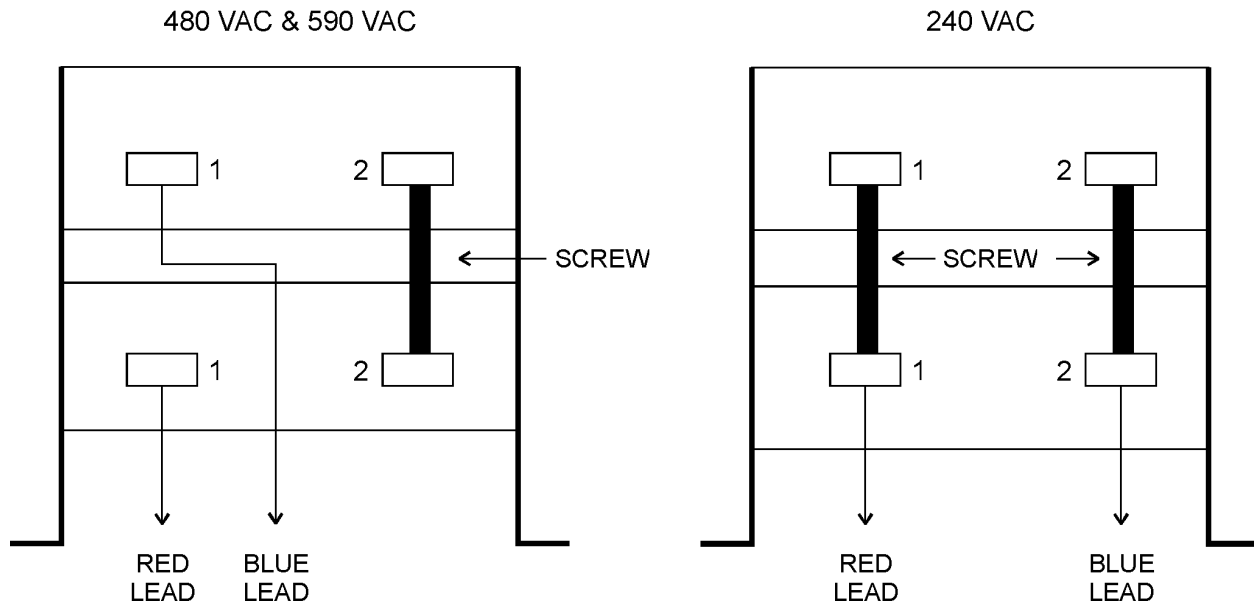

Connect each Tab #1 together with screw provided (copy the configuration of the #2 tabs), and move the BLUE wire to Tab #2.