

MMBOSS Series

User's Manual

Model:
MMBOSS05-24DC-1Q

Copyright © 2000 by Minarik Corporation

All rights reserved. No part of this manual may be reproduced or transmitted in any form without written permission from Minarik Corporation. The information and technical data in this manual are subject to change without notice. Minarik Corporation and its Divisions make no warranty of any kind with respect to this material, including, but not limited to, the implied warranties of its merchantability and fitness for a given purpose. Minarik Corporation and its Divisions assume no responsibility for any errors that may appear in this manual and make no commitment to update or to keep current the information in this manual.

Printed in the United States of America

Safety Warnings

- This symbol  denotes an important safety tip or warning. **Please read these instructions carefully** before performing any of the procedures contained in this manual.
- **DO NOT INSTALL, REMOVE, OR REWIRE THIS EQUIPMENT WITH POWER APPLIED.** Have a qualified electrical technician install, adjust and service this equipment. Follow the National Electrical Code and all other applicable electrical and safety codes, including the provisions of the Occupational Safety and Health Act (OSHA), when installing equipment.
- Reduce the chance of an electrical fire, shock, or explosion by proper grounding, over-current protection, thermal protection, and enclosure. Follow sound maintenance procedures.



It is possible for a drive to run at full speed as a result of a component failure. Minarik strongly recommends the installation of a master switch in the main power input to stop the drive in an emergency.

This drive is isolated from earth ground. Circuit potentials are at 115 VAC or 230 VAC above earth ground. Avoid direct contact with the printed circuit board or with circuit elements to prevent the risk of serious injury or fatality. Use a non-metallic screwdriver for adjusting the calibration trimpots. Use approved personal protective equipment and insulated tools if working on this drive with power applied.

Contents

Specifications	1
Dimensions	3
Installation	5
Mounting	.5
Wiring	.6
Shielding guidelines	.7
Heat sinking	.8
Fusing	.8
Speed adjust potentiometer mounting	.9
Quick-connect terminal block	.10
Connections	.11
Motor, power and fuse connections	.11
Optional switch connections	.14
Voltage follower signal connections	.16
Motor hall sensor connections	.17
Jumper Settings	.19
Input Voltage Range Select (SW501)	.19
Hall Sensor Spacing (SW502)	.19
Operation	21
Before applying power	.21
Startup	.22
Reversing	.23
Starting and Stopping Methods	.24
Automatic restart upon power restoration	.25
ENABLE/DISABLE switch	.25
RUN/BRAKE switch	.25
Coast to a stop	.25

Decelerate to minimum speed25
Calibration	27
MIN SPD28
MAX SPD28
CURRENT LIMIT29
GAIN30
Application Notes	31
Multiple fixed speeds31
Adjustable speeds using potentiometers in series32
Independent adjustable speeds33
DIRECTION switch34
Troubleshooting	35
Before troubleshooting35
Diagnostic LEDs36
Power On36
Fault36
Terminal Description37
Replacement Parts41
Index	42
Unconditional Warranty	47

Illustrations

Figure 1. MMBOSS Series Dimensions	3
Figure 2. Speed Adjust Potentiometer Mounting	9
Figure 3. Quick-Connect Terminal Plug	10
Figure 4. PCB Power, Fuse and Motor Connections	13
Figure 5. Optional Switch Connections	15
Figure 6. Voltage Signal Follower Connections	16
Figure 7. Sensor Feedback Connections	18
Figure 8. Jumper Locations	19
Figure 9. Decelerate to Minimum Speed Switch	26
Figure 10. Calibration Trimpot Layout	27
Figure 11. Multiple Fixed Speeds	31
Figure 12. Adjustable Speeds Using Potentiometers in Series	32
Figure 13. Independent Adjustable Speeds	33
Figure 14. DIRECTION Switch	34
Figure 15. Diagnostic LED Location	36
Figure 16. Terminal Assignments	37

Tables

Table 1. Line Fuse Chart	8
Table 2. Replacement Parts	41

Specifications

Maximum Phase Current (continuous)	5 ADC
DC Bus Voltage Input Range†	12 – 40 VDC
Maximum Phase Current Limit	1.5 times Maximum Phase Current (continuous)
Peak Phase Current Limit	2 times Maximum Phase Current (for 1 second)
Acceleration Time Range	6 seconds
Deceleration Time Range	6 seconds
Speed Regulation (typical)	0.06% of base speed
Speed Adjust Potentiometer	10K ohms
Analog Input Voltage Range (signal must be isolated)	0–10 VDC
Input Impedance	60K ohms
Power Device Switching Frequency (6–step, trapezoidal)	22 Khz
Hall sensor output , maximum	+5 VDC @ 20mA
Vibration	0.5G max. (0–50 Hz); 0.1G max. (>50 Hz)
Weight	2 lb
Ambient Operating Temperature Range	0–40°C

†Input voltage range is selected via SW501. Jumper terminals 1 and 2 for a voltage range of 15 - 40 VDC (this is the factory setting). Jumper terminals 2 and 3 for 12 - 15 VDC input.

Dimensions

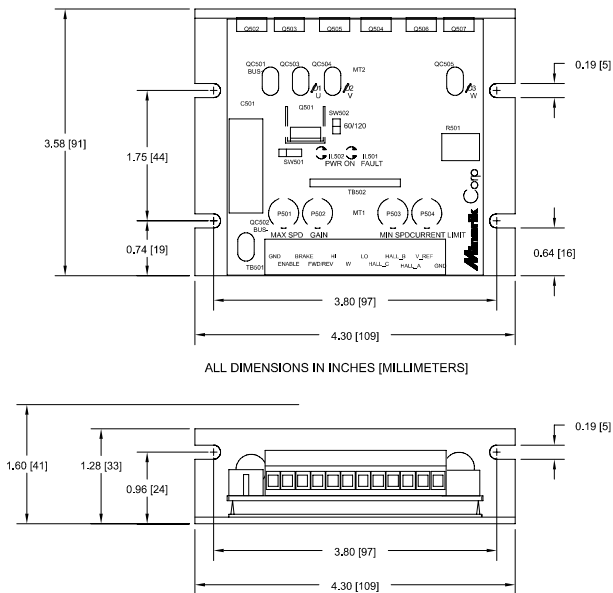

Figure 1. MMBOSS Series Dimensions

Installation



Warning

Do not install, rewire, or remove this control with input power applied. Doing so may cause fire or serious injury. Make sure you have read and understood the Safety Warnings before attempting installation.

Mounting

- Drive components are sensitive to electrostatic fields. Avoid direct contact with the circuit board. Hold drive by the chassis only.
- Protect the drive from dirt, moisture, and accidental contact. Provide sufficient room for access to the terminal block and calibration trim pots.
- Mount the drive away from heat sources. Operate the drive within the specified ambient operating temperature range.
- Prevent loose connections by avoiding excessive vibration of the drive.
- Mount drive with its board in either a horizontal or vertical plane. Six 0.19 in. (5 mm) wide slots in the chassis accept #8 pan head screws. Fasten either the large base or the narrow flange of the chassis to the subplate.

Wiring



Warning



Do not install, remove, or rewire this equipment with power applied. Failure to heed this warning may result in fire, explosion, or serious injury.

This drive is isolated from earth ground. Circuit potentials are at 115 or 230 VAC above ground. To prevent the risk of injury or fatality, avoid direct contact with the printed circuit board or with circuit elements.

Do not disconnect any of the motor leads from the drive unless power is removed or the drive is disabled. Opening any one motor lead may destroy the drive.

- Use 18–24 AWG wire for speed adjust potentiometer wiring. Use 16–18 AWG wire for DC line (L1, L2) and motor (phase 1, phase 2 and phase 3) wiring.

Shielding guidelines



Under no circumstances should power and logic leads be bundled together. Induced voltage can cause unpredictable behavior in any electronic device, including motor controls.

As a general rule, Minarik recommends shielding all conductors.

If it is not practical to shield power conductors, Minarik recommends shielding all logic-level leads. If shielding is not practical, the user should twist all logic leads with themselves to minimize induced noise.

It may be necessary to earth ground the shielded cable. If noise is produced by devices other than the drive, ground the shield at the drive end. If noise is generated by a device on the drive, ground the shield at the end away from the drive. Do not ground both ends of the shield.

If the drive continues to pick up noise after grounding the shield, it may be necessary to add AC line filtering devices, or to mount the drive in a less noisy environment.

Logic wires from other input devices, such as motion controllers and PLL velocity controllers, must be separated from power lines in the same manner as the logic I/O on this drive.

Heat sinking

The MMBOSS series drive contains sufficient heat sinking in its basic configuration. There is no need for additional heat sinking.

Fusing

All Minarik drives should be protected by fuses. Use fast acting fuses, such as Bussman® 3AG or equivalent, rated for approximately 150% – 200% of the maximum phase current. Fuse only the BUS+ DC input voltage line. See the fuse chart below for recommended line fuse sizes:

Table 1. Line Fuse Chart

Maximum Phase Current (DC Amps)	Fuse Rating (Amps)¹
0.5	1
0.8	1.5
1.5	3
2.6	5
3.5	8
5.0	10

Notes:

1. Use 250 volt fuses regardless of the input voltage.

Speed adjust potentiometer mounting



Warning

Be sure that the potentiometer tabs do not make contact with the potentiometer enclosure. Grounding the input will cause damage to the drive.

Mount the speed adjust potentiometer through a 0.38 in. (10 mm) hole with the hardware provided (Figure 2). Install the circular insulating disk between the panel and the 10K ohm speed adjust potentiometer. Twist the speed adjust potentiometer wire to avoid picking up unwanted electrical noise. If potentiometer leads are longer than 18 in. (457 mm), use shielded cable.

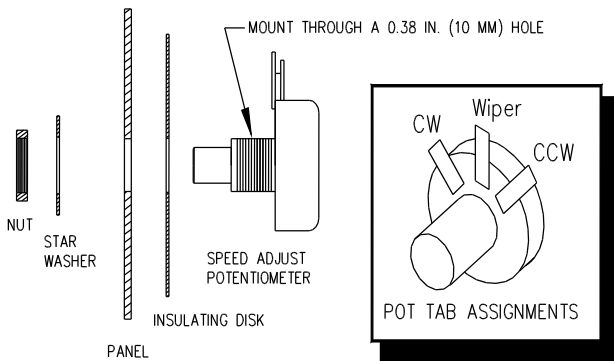

Figure 2. Speed Adjust Potentiometer Mounting

Quick-connect terminal block

The quick-connect terminal block, found on the 1Q plug in card, is composed of a header block and terminal plug (Figure 3). To use the quick-connect terminal block:

1. Carefully pull terminal plug from header block.
2. With a small flat-head screwdriver, turn terminal plug screw counterclockwise to open wire clamp.
3. Insert stripped wire into the large opening in front of the plug.
4. Turn the terminal plug screw clockwise to clamp the wire.
5. Repeat steps 2–4 for each terminal until all connections are made.
6. Insert plug into header until securely fastened.

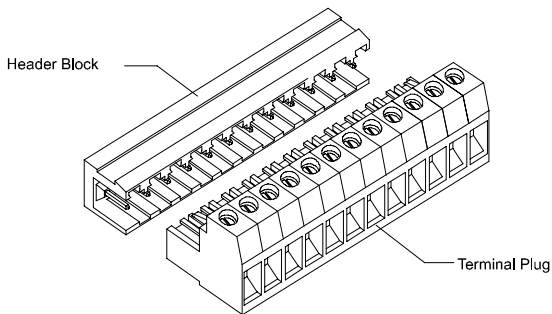

Figure 3. Quick-Connect Terminal Plug

Connections



Warning

Do not connect this equipment with power applied.

Failure to heed this directive may result in fire or serious injury.

Minarik strongly recommends the installation of a master power switch in the voltage input line, as shown in Figure 4 (page 13). The switch contacts should be rated at a minimum of 200% of motor nameplate current and 125 volts.

Motor, power and fuse connections



Warning

Do not reverse power input leads or apply reverse voltage at the drive terminals. The drive will be damaged.

Connect switches to COM terminal 1 only. **Do not connect switches to COM terminal 12.** Terminal 12 is to be used for external hall sensors and encoders only.

Connect the power input leads, an external line fuse and a three-phase motor to the drive's printed circuit board (PCB) as shown in Figure 4, page 13.

Motor

Connect a three-phase motor to PCB terminals U, V and W, as shown in Figure 4. Connect motor phase A (or phase 1) to drive terminal U. Connect motor phase B (or phase 2) to drive terminal V. Connect motor phase C (or phase 3) to drive terminal W.

Power input



Warning

Minarik strongly recommends the installation of a master power switch in the voltage input line, as shown in Figure 4. The switch contacts should be rated at a minimum of 200% of motor nameplate current and 125 volts.

Connect the DC input power leads to PCB terminals BUS+ and BUS-. Connect the positive (+ or high) to BUS+. Connect the negative (- or common) to BUS-.

Line fuse

Wire an external line fuse between the stop switch (if installed) and the BUS+ terminal. The line fuse should be rated at 125 volts and 150 - 200% of maximum motor nameplate current. Refer to the line fuse chart on page 8 for fuse ratings.

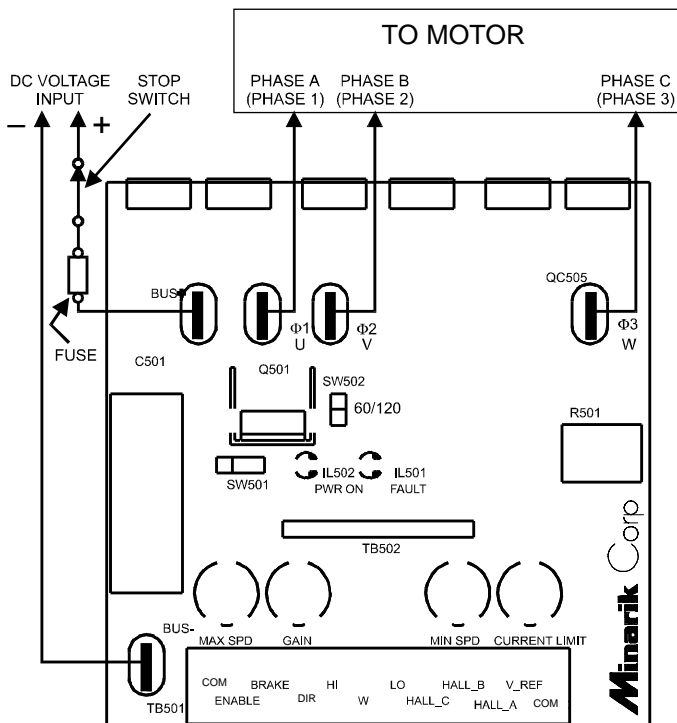

Figure 4. PCB Power, Fuse and Motor Connections

Optional switch connections



Warning

Do not reverse power input leads or apply reverse voltage at the drive terminals. The drive will be damaged.

Connect switches to COM terminal 1 only. **Do not connect switches to COM terminal 12.** Terminal 12 is to be used for external hall sensors and encoders only.

Connect the following switches to the terminal plug as shown in Figure 5.

ENABLE/DISABLE switch

Install a single-pole, single-throw switch between the ENABLE and COM terminals (Figure 5). Close the switch to disable the drive and coast the motor to a stop. Leave open to enable the drive and run the motor.

RUN/BRAKE switch

Install a single-pole, single-throw switch between the BRAKE and COM terminals (Figure 5). Close the switch to brake the motor to a stop. Open the switch to run the motor and accelerate to set speed.

DIRECTION switch

Install a single-pole, single-throw switch between the DIR and COM terminals (Figure 5). Open or close the switch as required to change direction.

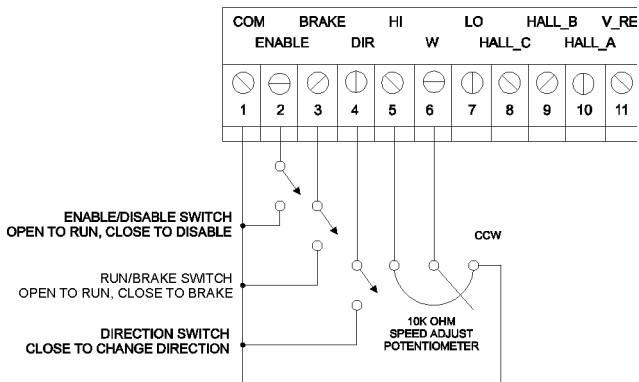

Figure 5. Optional Switch Connections

Voltage follower signal connections

Instead of using a speed adjust potentiometer, BOSS series drives may be wired to follow a floating voltage signal that is isolated from earth ground. Connect a 0 to +10 VDC signal to terminals 1 (COM) and 6 (WIPER) as shown in Figure 6.

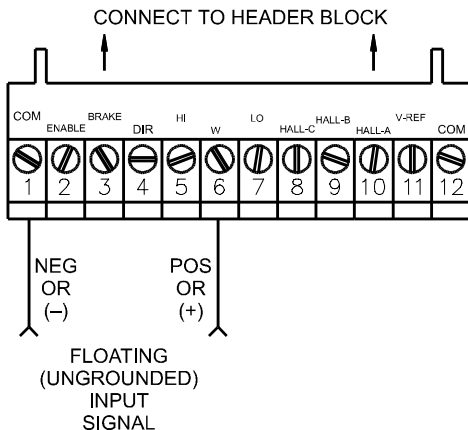

Figure 6. Voltage Signal Follower Connections

Motor hall sensor connections



Warning

This drive provides a +5 VDC, 20 mA maximum output to drive the Hall sensors. If the encoder draws more than 20 mA, an external power supply must be used

MBOSS-series drives work with three-phase, 12 – 40 VDC brushless motors with nulled hall sensors (60° or 120° electrical spacing). Hall sensors are not allowed to be advanced or retarded. To reverse motor rotation, BOSS switches hall sensor sequence, eliminating the need to switch motor leads.

To run with encoder (hall-track) feedback, refer to Figure 7 on page 18. The encoder power supply voltage is provided at TB501 terminal 11 (Vref) and terminal 12 (ground).

USE THIS
ARRANGEMENT
IF THE SENSOR
DRAWS LESS
THAN 20mA DC

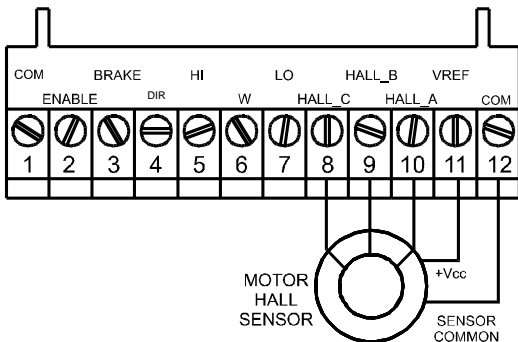

USE THIS
ARRANGEMENT
IF THE SENSOR
DRAWS MORE
THAN 20mA DC

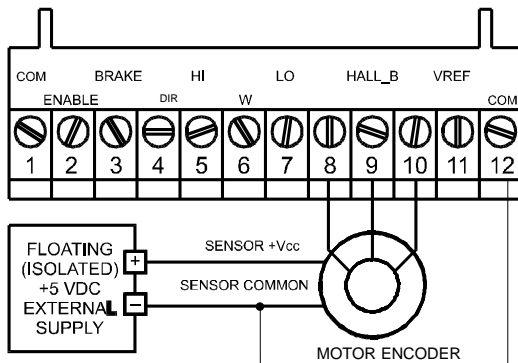

Figure 7. Sensor Feedback Connections

Jumper Settings

Input Voltage Range Select (SW501)

Jumper SW501 selects the DC input voltage range. Jumper terminals 1 and 2 for a voltage range of 15 - 40 VDC (this is the factory setting). Jumper terminals 2 and 3 for 12 - 15 VDC input.

Hall Sensor Spacing (SW502)



NOTE: This drive provides a +5 VDC, 20mA maximum output to drive the Hall sensors. To run with encoder (hall-track) feedback, refer to Figure 7. This voltage is provided at TB501 terminal 11 (V_{ref}) and terminal 12 (ground).

Set the motor hall sensor header according to the hall effect feedback spacing. Jumper SW502 if the hall effect feedback spacing is 120°. Do not add a jumper if the hall effect feedback spacing is 60°. The factory default is 120° (installed).

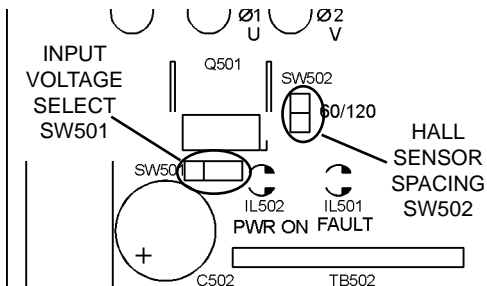

Figure 8. Jumper Locations

Operation



Warning

Dangerous voltages exist on the drive when it is powered, and up to 30 seconds after power is removed and the motor stops. BE ALERT. High voltages can cause serious or fatal injury. For your safety, use personal protective equipment (PPE) when operating this drive.

Before applying power:

- Verify that no conductive material is present on the printed circuit board.
- Ensure that all jumpers are properly set.

Startup

1. Verify that no conductive material is present on the PCB.
2. Check that the enable/disable switch is in the enable position (open).
3. Check that the run/brake switch is in the run position (open).
4. Set the DIR switch to the direction you want the motor to rotate upon startup.
5. Set the speed adjust potentiometer to zero (fully CCW).
6. Apply DC voltage input to the drive.
7. Slowly advance the speed adjust potentiometer so that motor speed increases in the desired direction. If a voltage signal is used, slowly increase the signal. The motor will slowly accelerate as the potentiometer is turned CW, or as the voltage signal is increased. Continue until the desired speed is reached.

Reversing



Warning

Do not change direction with the motor running. Frequent changes in direction with the motor running may damage the motor. Always wait for the motor to come to a stop before changing direction.

NOTE: After a one-second time delay, all drives automatically run to set speed when power is applied and the ENABLE input is jumpered.

To change direction, set the DIR switch to the opposite position. To avoid motor damage from high braking currents, brake the motor to a stop before reversing. An alternative is to close the ENABLE/DISABLE switch or remove power to the drive before reversing. Always wait for the motor to come to a stop before reversing.

Starting and Stopping Methods



Warning

Decelerating to minimum speed, regenerative braking, or coasting to a stop is recommended for frequent starts and stops. Do not use any of these methods for emergency stopping. They may not stop a drive that is malfunctioning. Removing AC line power (both L1 and L2) is the only acceptable method for emergency stopping.

For this reason, **Minarik strongly recommends installing an emergency stop switch on the BUS+ input** (see *Connections*).

NOTE: After a one-second time delay, all drives automatically run to set speed when power is applied and the ENABLE input is jumpered.

Frequent decelerating to minimum speed or regenerative braking produces high torque. This may cause damage to motors, especially gearmotors that are not properly sized for the application.

Automatic restart upon power restoration

After a one-second time delay, all drives automatically run to set speed when power is applied and the ENABLE input is jumpered.

ENABLE/DISABLE switch

Install a single-pole, single-throw switch between the ENABLE and COM terminals. Close the switch to disable the drive and coast the motor to a stop. Leave open to enable the drive and run the motor.

RUN/BRAKE switch

Install a single-pole, single-throw switch between the BRAKE and COM terminals. Close the switch to brake the motor to a stop. Open the switch to accelerate the motor to set speed.

Coast to a stop

To coast the motor to a stop, remove power to the drive. You may also close the ENABLE/DISABLE switch to coast to a stop.

Decelerate to minimum speed

Install a single-pole, single-throw switch between the speed adjust potentiometer wiper terminal and the drive W terminal (Figure 9, page 26). The motor will coast to minimum speed when the switch is opened. The motor will accelerate to set speed when the switch is closed.

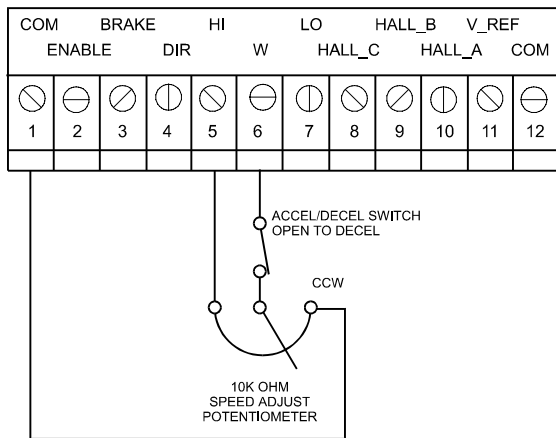

Figure 9. Decelerate to Minimum Speed Switch

Calibration



Warning

Dangerous voltages exist on the drive when it is powered, and up to 30 seconds after power is removed and the motor stops. When possible, disconnect the voltage input from the drive before adjusting the trimpots. If the trimpots must be adjusted with power applied, use insulated tools and the appropriate personal protection equipment. **BE ALERT.** High voltages can cause serious or fatal injury.

Each drive is factory calibrated to its maximum horsepower rating. Readjust the calibration trimpot settings to accommodate lower horsepower motors.

All adjustments increase with CW rotation, and decrease with CCW rotation. Each trimpot is identified on the printed circuit board.

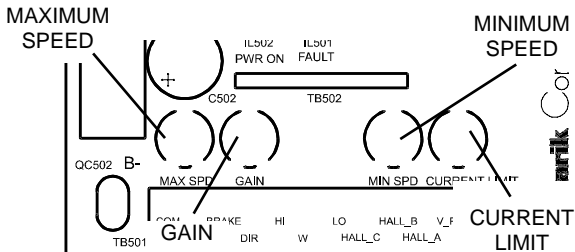

Figure 10. Calibration Trimpot Layout

MIN SPD

The MIN SPD setting determines the motor speed when the speed adjust potentiometer is turned full CCW. It is factory set to zero speed.

To calibrate, turn the speed adjust potentiometer full CCW. To set the minimum speed to zero, rotate the MIN SPD trimpot CCW until the motor has stopped. To set a minimum speed higher than zero, rotate the MIN SPD trimpot CW until the motor is running at the desired minimum speed.

MAX SPD

The MAX SPD setting determines the motor speed when the speed adjust potentiometer is turned full CW. It is factory set for maximum rated speed.

To calibrate, set the MAX SPD trimpot full CCW. Turn the speed adjust potentiometer full CW. Adjust the MAX SPD trimpot until the desired maximum motor speed is reached.

Note: Check the MIN SPD and MAX SPD adjustments after recalibrating to verify that the motor runs at the desired minimum and maximum speed.

CURRENT LIMIT



Warning

Although CURRENT LIMIT is set to 120% of motor nameplate current rating, continuous operation beyond that rating may damage the motor. If you intend to operate beyond the rating, contact your Minarik representative for assistance.

The CURRENT LIMIT setting determines the maximum armature current output of the drive. It is factory set at 120% of rated motor current.

Recalibrate the TQ LIMIT setting when using a lower horsepower motor. Use the following procedure:

1. With the power disconnected from the control, connect an ammeter in series with one of the motor phases.
2. Connect a stall to the motor shaft.
3. Apply power to the drive, and run the motor at 200 RPM.
4. Stall the motor. The current limit value should register on the ammeter. If it does not, stall the motor again until the ammeter shows the current limit value.
5. Adjust the TQ LIMIT trimpot CW until the armature current is 120% of motor rated current.
6. Remove power from the drive.
7. Remove the stall from the motor.

GAIN

The GAIN setting determines motor regulation under load. As a rule, the factory setting (at 12 o'clock) is sufficient for most applications.

Set the gain trimpot full CCW for minimum regulation, or full CW for maximum regulation. Test the motor gain by applying a load to the motor and checking the change in motor speed. The drive will maintain motor speed better with higher gain settings.

Application Notes

Multiple fixed speeds

Replace the speed adjust potentiometer with series resistors with a total series resistance of 10K ohms (Figure 11). Add a single-pole, multi-position switch with the correct number of positions for the desired number of fixed speeds.

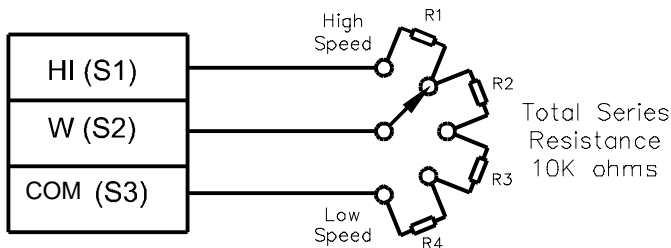

Figure 11. Multiple Fixed Speeds

Adjustable speeds using potentiometers in series

Replace the speed adjust potentiometer with a single pole, multi-position switch, and two or more potentiometers in series, with a total series resistance of 10K ohms. Figure 12 shows a connection for fixed high and low speed adjust potentiometers.

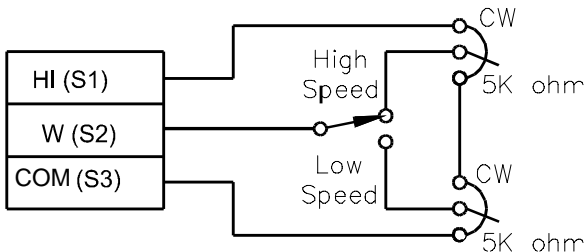

Figure 12. Adjustable Speeds Using Potentiometers in Series

Independent adjustable speeds

Replace the speed adjust potentiometer with a single pole, multi-position switch, and two or more potentiometers in parallel, with a total parallel resistance of 10K ohms. Figure 13 shows the connection of two independent speed adjust potentiometers that can be mounted at two separate operating stations.

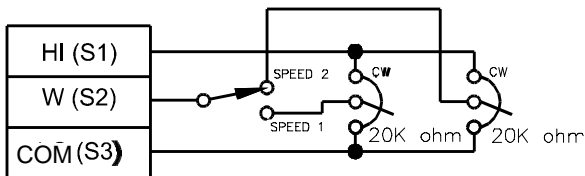

Figure 13. Independent Adjustable Speeds

DIRECTION switch

Use a single-pole, two-position switch with a single speed adjust potentiometer to reverse a motor (Figure 14). Brake the drive before reversing by using a RUN/BRAKE switch as shown. This will help prevent high reversing currents from damaging the drive or motor.

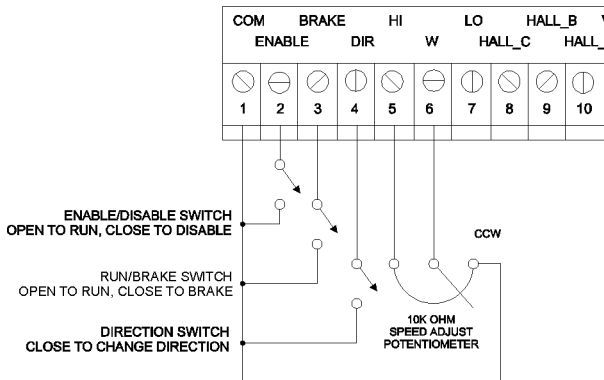

Figure 14. DIRECTION Switch

Troubleshooting



Warning

Dangerous voltages exist on the drive when it is powered. When possible, disconnect the drive while troubleshooting. High voltages can cause serious or fatal injury.

Before troubleshooting

Perform the following steps before starting any procedure in this section:

- Disconnect voltage input from the drive. Wait 30 seconds for power to discharge
- Check the drive closely for damaged components.
- Check that no wire chips or other foreign material has become lodged on the printed circuit board.
- Verify that every connection is correct and in good condition.
- Verify that there are no short circuits or grounded connections.
- Check that the drive's rated phase current and RMS voltage are consistent with the motor ratings.

For additional assistance, contact your local Minarik® distributor, or the factory direct:

1-800-MINARIK (646-2745) or Fax: 1-800-394-6334.

Diagnostic LEDs

Power On

The POWER ON LED lights when power is applied to the drive and the plug-in card is connected properly.

Fault

The FAULT LED lights in any of the following conditions:

1. The hall sensors are miswired, not operating properly, not properly nulled, or draw current in excess of 20 mA..
2. The drive reaches its peak phase current limit.
3. The drive has insufficient DC input power.
4. The enable switch is closed (drive is disabled).

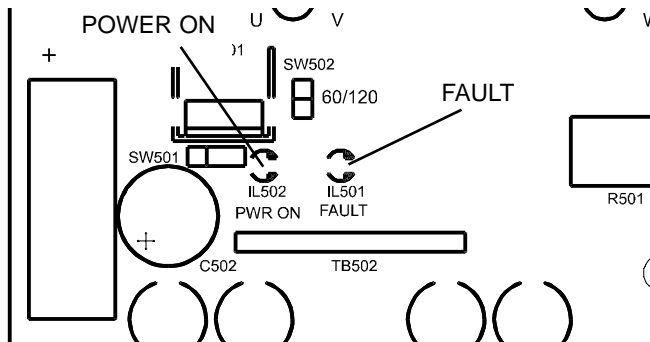

Figure 15. Diagnostic LED Location

Terminal Description

Refer to Figure 16 for TB501 and TB502 locations. The terminal assignments are identical for TB501 and TB502.

COM

Circuit common

ENABLE (terminal 2)

Short to COM to coast the motor to a stop; leave open to run the motor.

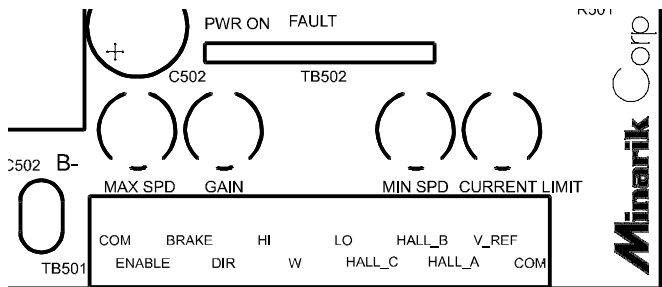

Figure 16. Terminal Assignments

BRAKE (terminal 3)

When shorted to COM, high-side power devices turn off, low-side power devices turn on, and motor brakes to a stop. Current is dissipated through the motor windings; a brake resistor is not required. Leave open to run the motor.

DIR (terminal 4)

Short to COM for forward direction; leave open for reverse direction. Hall sensors A and C (or 1 and 3) are exchanged, reversing commutation sequence.

HI (terminal 5)

Floating +10 VDC reference for 10K Ω speed adjust potentiometer.

W (terminal 6)

Accepts floating (ungrounded) 0 to +10 VDC reference or 10K Ω speed adjust potentiometer wiper.

LO (terminal 7)

Floating -10 VDC reference; used on future drives.

HALL C,B,A (terminals 8-10)

Inputs for motor hall sensors.

V_{ref} (terminal 11)

Floating (isolated) +5 VDC supply.

**Warning**

V_{ref} has a maximum capacity of 20mADC. Connecting any device which draws more than 20 mA may damage the drive.

Motor does not run

1. Check for blown fuses or tripped circuit breaker.
2. Verify that the speed adjust potentiometer is not set to zero position.
3. Verify that the enable/disable or run/brake terminals are not shorted to COM.
4. Verify that the drive is receiving power from the AC or DC voltage input. The green POWER ON LED should be lit when AC or DC voltage input is applied.
5. Check that the drive is not in current limit. The red TQ LIMIT LED must be off. If the red TQ LIMIT LED is on, verify that the motor is not jammed. It may be necessary to increase the TQ LIMIT setting.
6. Check that the encoder, if installed, does not draw current in excess of 20 mADC.

Fuse or circuit breaker blows

1. Check all wiring for shorts, grounds, or misconnections.
2. Check that the drive is configured to match the motor rating.
3. Check that the motor is not jammed or restricted from movement.
4. Check that the fuse size is correct for the motor being driven.

Motor runs too fast at the maximum speed setting

Check that the MIN SPD and MAX SPD settings are not set too high (page 28).

Motor will not stop when the speed adjust potentiometer is full counterclockwise

Turn the MIN SPD trimpot CCW until the motor stops (page 28).

Motor runs in the opposite direction

Open or close the DIR switch so that the motor runs in the opposite direction.

Motor slows under load

1. Check that the drive has been correctly calibrated for the motor.
2. Check that the motor is not overloaded.
3. Readjust the GAIN slightly CW until motor runs at proper speed (page 30).

Motor is unstable under load

Reduce the GAIN setting until motor speed is stabilized (page 30).

Replacement Parts

Replacement parts are available from Minarik Corporation and its distributors for this drive series.

Table 2. Replacement Parts

<u>Model No.</u>	<u>Symbol</u>	<u>Description</u>	<u>Minarik P/N</u>
MMBOSS05-24DC-1Q			
	C501	Capacitor, 330 mF	011-0123
	Q501	TIP120 Transistor	070-0094
	Q502,504,506	IRF9Z34 P-channel MOSFET	070-0095
	Q503,505,507	IRFZ44 N-channel MOSFET	070-0060
		Potentiometer Kit	202-0098

Index

Application Notes 31

Adjustable speeds using potentiometers in series 32

DIRECTION switch 34

Independent adjustable speeds 33

Multiple fixed speeds 31

Calibration 27

CURRENT LIMIT trimpot 29

GAIN trimpot 30

MAX SPD trimpot 28

MIN SPD trimpot 28

Contents ii

Dimensions 3

Illustrations iv

Installation 5

Connections 11

Motor, power and fuse connections 11

Line fuse 12

Motor 12

Power input 12

Fusing 8

Heat sinking 8

Jumper Settings 19

Input Voltage Range Select (SW501) 19

Hall Sensor Spacing (SW502) 19

Motor hall sensor connections 17

Optional switch connections 14

DIRECTION switch 15

ENABLE/DISABLE switch 14

RUN/BRAKE switch 14

Quick-connect terminal block 10

Speed adjust potentiometer mounting 9

Voltage follower signal connections 16

Wiring 6

Shielding guidelines 7

Operation 21

Before applying power: 21

Reversing 23

Starting and Stopping Methods 24

Automatic restart upon power restoration 25

Coast to a stop 25

ENABLE/DISABLE switch 25

RUN/BRAKE switch 25

Startup 22

Safety Warnings i

Specifications 1

Tables v

Troubleshooting 35

Before troubleshooting 35

Diagnostic LEDs 36

Fault 36

Power On 36

Replacement Parts 41

Terminal Description 37

Troubleshooting Tree 39

Unconditional Warranty 47

Notes

Notes

Notes

Unconditional Warranty

A. Warranty

Minarik Corporation (referred to as “the Corporation”) warrants that its products will be free from defects in workmanship and material for twelve (12) months from date of manufacture thereof. Within this warranty period, the Corporation will repair or replace such products that are returned to Minarik Corporation, 901 East Thompson Avenue, Glendale, CA 91201-2011 USA.

This warranty shall not apply to any product that has been repaired by unauthorized persons. The Corporation is not responsible for removal, installation, or any other incidental expenses incurred in shipping the product to and from the repair point.

B. Disclaimer

The provisions of Paragraph A are the Corporation’s sole obligation and exclude all other warranties of merchantability for use, express or implied. The Corporation further disclaims any responsibility whatsoever to the customer or to any other person for injury to the person or damage or loss of property of value caused by any product that has been subject to misuse, negligence, or accident, or misapplied or modified by unauthorized persons or improperly installed.

C. Limitations of Liability

In the event of any claim for breach of any of the Corporation’s obligations, whether express or implied, and particularly of any other claim or breach of warranty contained in Paragraph A, or of any other warranties, express or implied, or claim of liability that might, despite Paragraph B, be decided against the Corporation by lawful authority, the Corporation shall under no circumstances be liable for any consequential damages, losses, or expense arising in connection with the use of, or inability to use, the Corporation’s product for any purpose whatsoever.

An adjustment made under warranty does not void the warranty, nor does it imply an extension of the original 12-month warranty period. Products serviced and/or parts replaced on a no-charge basis during the warranty period carry the unexpired portion of the original warranty only.

If for any reason any of the foregoing provisions shall be ineffective, the Corporation’s liability for damages arising out of its manufacture or sale of equipment, or use thereof, whether such liability is based on warranty, contract, negligence, strict liability in tort, or otherwise, shall not in any event exceed the full purchase price of such equipment.

Any action against the Corporation based upon any liability or obligation arising hereunder or under any law applicable to the sale of equipment or the use thereof, must be commenced within one year after the cause of such action arises.



901 E Thompson Avenue

Glendale, CA 91201-2011

Tel: 1-800-MINARIK (646-2745)

Fax: 1-800-394-6334

www.minarikcorp.com

Document number 250-0288, Revision 1

Printed in the U.S.A – 6/00

\$11.00 U.S.A. – \$12.00 Canada