

User's Manual

RG501A/RG511A



Cased, Regenerative, Variable Speed DC Drives

JOG

FWD

STOP

Minarik

Automation
& Control

MOTOR MASTER
RG SERIES

Copyright © 1998 by
Minarik Corporation

All rights reserved. No part of this manual may be reproduced or transmitted in any form without written permission from Minarik Corporation. The information and technical data in this manual are subject to change without notice. Minarik Corporation and its Divisions make no warranty of any kind with respect to this material, including, but not limited to, the implied warranties of its merchantability and fitness for a given purpose. Minarik Corporation and its Divisions assume no responsibility for any errors that may appear in this manual and make no commitment to update or to keep current the information in this manual.

Printed in the United States of America.

Safety Warnings

- This symbol  denotes an important safety tip or warning. Please read these sections carefully prior to performing any of the instructions contained in that section.
- Have a qualified electrical maintenance technician install, adjust and service this equipment. Follow the National Electrical Code and all other applicable electrical and safety codes, including the provisions of the Occupational Safety and Health Act (OSHA), when installing equipment.
- Reduce the chance of an electrical fire, shock, or explosion by proper grounding, over-current protection, thermal protection, and enclosure. Follow sound maintenance procedures.
- **It is possible for a drive to run at full speed as a result of a component failure.** Please ensure that a master switch has been placed in the AC line to stop the drive in an emergency.
- **This drive is isolated from earth ground.** Circuit potentials are at 115 VAC or 230 VAC above earth ground. Avoid direct contact with the printed circuit board or with circuit elements to prevent the risk of serious injury or fatality. Use a non-metallic screwdriver for adjusting the calibration trim pots.

Contents

Introduction	1
Specifications	2
Dimensions	3
Regenerative Drives	4
Installation	5
Mounting	5
Wiring	5
Line fusing	6
Field fusing	7
Cage-clamp terminals	7
Connections	8
Field output	9
Limit switch connections (optional)	9
Remote pushbuttons (optional)	9
Slide switches	10
Mode select switches	11
Operation	12
Before applying power	12
Startup	12
Jogging the motor	13
Limit switch operating modes	14
Warnings	16
Calibration	17
Power board trimpots	17
MIN SPD	17
MAX SPD	17
FWD ACC	18
REV ACC	18
IR COMP	18
FWD TQ	19
REV TQ	20
DB	21
TACH	22
Logic board trimpots	22
FWD JOG	22
REV JOG	23
DWELL TIME	23

Troubleshooting	24
Block Diagram	28
Prewired Connections	29
Replacement Parts	30
Certificate of Compliance	31
Limited Warranty	inside back cover

Illustrations

Fig.	Description	Page
1.	RG501A and RG511A Dimensions	.2
2.	Four-Quadrant Operation	.3
3.	Line and Field Fusing	.6
4.	Cage-clamp terminals	.6
5.	Connections	.7
6.	Limit switch connections (optional)	.8
7.	Remote pushbuttons (optional)	.8
8.	Slide switches	.9
9.	Mode select switches	.10
10.	Typical FWD TQ, REV TQ and IR COMP Settings for RG501A	.19
11.	Typical FWD TQ, REV TQ and IR COMP Settings for RG511A	.20
12.	Deadband Settings	.20
13.	Block Diagram	.27
14.	Prewired Connections (Power)	.28
17.	Prewired Connections (Signal)	.29

Tables

Fig.	Description	Page
1.	Recommended Line Fuse Sizes	5
2.	Field Output Connections	8
3.	Replacement Parts	30
4.	AC Line Filters	31
5.	Armature Filters	32

Specifications

Model	Max. Armature Current (Amps DC)	HP Range with 115 VAC Applied	HP Range with 230 VAC Applied
RG501A	10.0	1/4–1	1/2–2
RG511A	3.0	1/20–1/8	1/10–1/4

AC Line Voltage	115/230 VAC, $\pm 10\%$, 50/60 Hz, single phase		
Armature Voltage (115 VAC Input)	0–90 VDC		
Armature Voltage (230 VAC Input)	0–180 VDC		
Form Factor	1.37 at base speed		
Field Voltage (115 VAC Input)	50 VDC (F1 to L1); 100 VDC (F1 to F2)		
Field Voltage (230 VAC Input)	100 VDC (F1 to L1); 200 VDC (F1 to F2)		
Maximum Field Current	1 ADC		
Acceleration Time Range (with no load)	0.5–15 seconds		
Deceleration Time Range (with no load)	0.5–15 seconds		
Analog Input Voltage Range (isolated; RB1 to S2)	–10 to +10 VDC		
Input Impedance (RB1 to S2)	32K ohms		
Load Regulation			
with Armature Feedback	1% of base speed or better		
with Tachogenerator Feedback	0.1% of base speed		
Dwell Time	0.1 – 1 second (0.1 second increments)		
Vibration	0.5G max. (0–50 Hz) 0.1G max. (>50 Hz)		
Ambient Temperature Range	10°C–40°C		
Weight	8.3 lb		

Dimensions

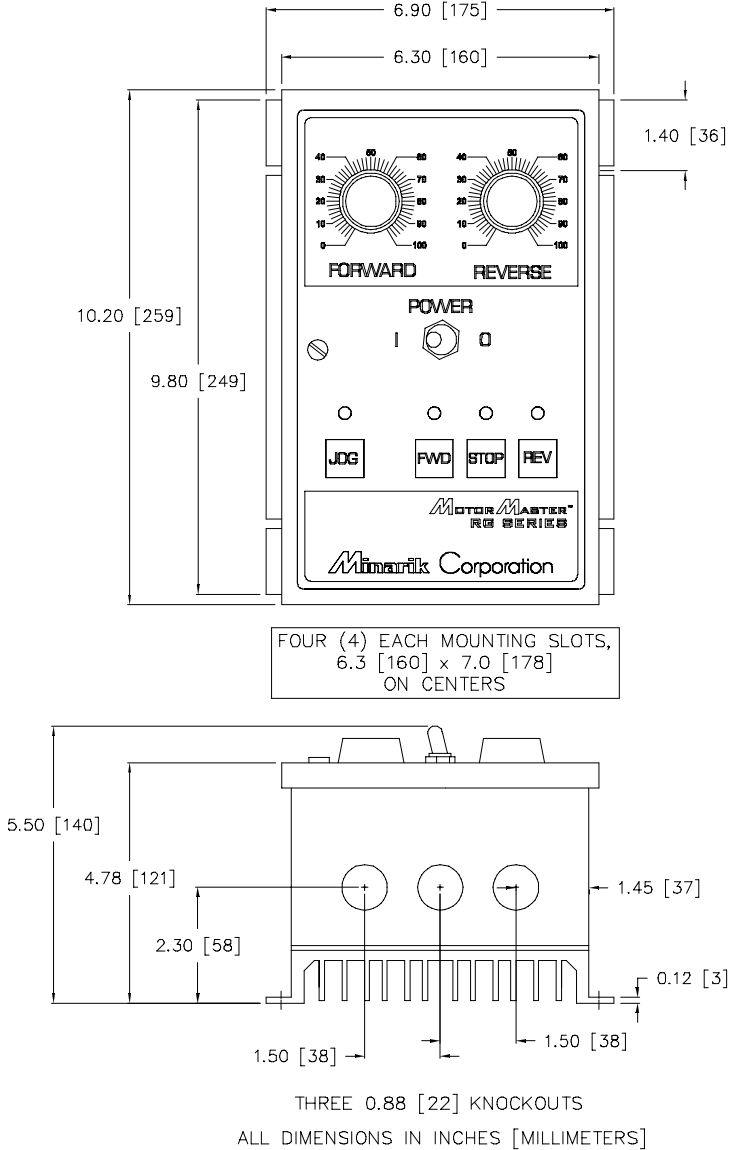

Figure 1. RG501A and RG511A Dimensions

Regenerative Drives

Most non-regenerative, variable-speed DC drives control current flow to a motor in one direction. The direction of current flow is the same direction as the motor rotation. Non-regenerative drives operate in Quadrant 1, and also in Quadrant 3 if the drive is reversible (see Figure 2). Motors must stop before reversing direction. Unless dynamic braking is used, non-regenerative drives cannot oppose an overhauling load, and cannot decelerate a load faster than coasting to a lower speed.

Regenerative drives operate in two additional quadrants: Quadrant 2 and Quadrant 4. In these quadrants, motor torque is in the opposite direction of motor rotation.

Regenerative drives can reverse a motor without contactors, switches, brake resistors, or inhibit plugs. They can also control an overhauling load and decelerate a load faster than it would take to coast to a lower speed.

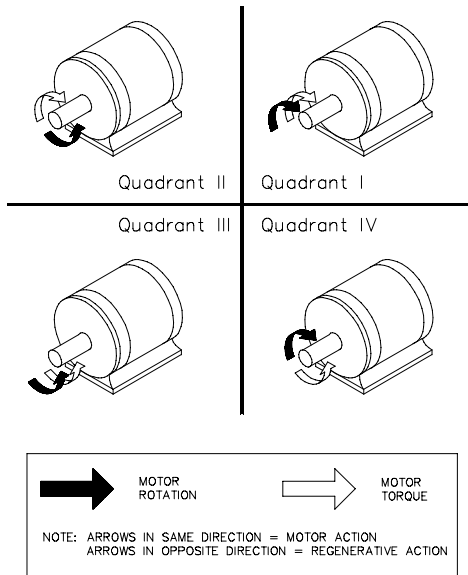

Figure 2. Four Quadrant Operation

Installation

Mounting

NEMA 4X cased drives come with three 0.88 inch (22 mm) conduit knockout holes at the bottom of the case. The units may be vertically wall mounted using the four 0.25 inch (6 mm) slotted holes on the attached heat sink. For motor loads less than 5 ADC, the drive may be bench mounted horizontally, or operated without mounting.

1. Install the mounting screws.
2. For access to the terminal strip, turn the slotted screw on the front cover counterclockwise until it is free from the case. The right side of the cover is hinged to the case. Lift or pull the slotted screw to open the case.
3. Carefully remove the conduit knockouts by tapping them into the case and twisting them off with pliers.
4. Install conduit hardware through the 0.88 inch (22 mm) conduit holes. Connect external wiring to the terminal block.
5. Grasp the slotted screw and tilt the front cover back into place. Avoid pinching any wires between the front cover and the case.
6. Turn the slotted screw clockwise until tight to secure the front cover.
7. Set the POWER switch to the **0** (OFF) position before applying the AC line voltage.

Wiring

Use 14 AWG wire for AC line voltage (L1 and L2) and motor armature (A1 and A2) wiring. Use 16 AWG wire for motor field (F1 and F2) and tachogenerator (T1 and T2) wiring.

(continued)

Use shielded cable if wires are longer than 12 inches (30 cm) to avoid picking up unwanted electrical noise.

It may be necessary to earth ground the shielded cable. If noise is produced by devices other than the drive, ground the shield at the drive end. If noise is generated by a device on the drive, ground the shield at the end away from the drive. Do not ground both ends of the shield.

- ⚠ Do not bundle logic wires with power carrying wires that can cause erratic operation. Keep logic wires in a conduit separated by at least 2 inches from power carrying wires. Do not allow logic wires to travel in parallel to power carrying wires for more than 1 inch.

⚠ Line fusing

RG501A and RG511A drives have line fuses preinstalled to fuseholders FU501 and FU502 (see Figure 3 for location). Factory installed line fuses are rated for maximum rated horsepower. Resize line fuses if a lower rated horsepower motor is used. Table 1 lists the recommended line fuse sizes. Use fast acting fuses rated for 250 VAC or higher, and approximately 150% of the maximum armature current.

Table 1. Recommended Line Fuse Sizes

90 VDC Motor Horsepower	180 VDC Motor Horsepower	Max. DC Armature Current (amps)	AC Line Fuse Size (amps)
1/20	1/10	0.5	3
1/15	1/8	0.8	3
1/8	1/4	1.5	5
1/6	1/3	1.7	5
1/4	1/2	2.6	8
1/3	3/4	3.5	8
1/2	1	5.0	10
3/4	1 1/2	7.6	15
1	2	10	20

Minarik Corporation offers two fuse kits: part number 050-0069 (3-8A Fuse Kit) and 050-0073 (5-20A Fuse Kit). Both fuse kits include a 1/2A pico fuse (part number 050-0074) which protects the transformer and logic.

Field fusing

To protect the motor field of shunt wound motors, all RG501A and RG511A drives have 1.5A 3AG field fuses installed to fuseholder FU503 (see Figure 3). If this fuse needs to be replaced, use a fuse of the same rating.

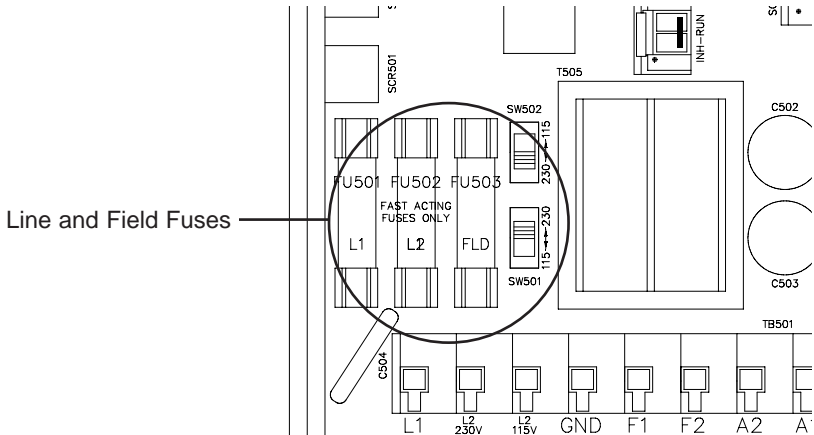
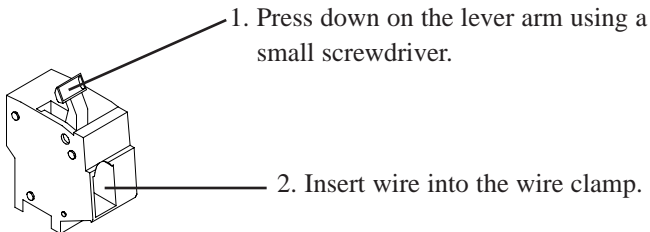

Figure 3. Line and Field Fuses

Cage-clamp terminals

RG Series drive connections are made to cage-clamp terminals. To insert a wire into a terminal, see Figure 4.



3. Release the lever arm to clamp wire.

Figure 4. Cage-Clamp Terminal

Connections

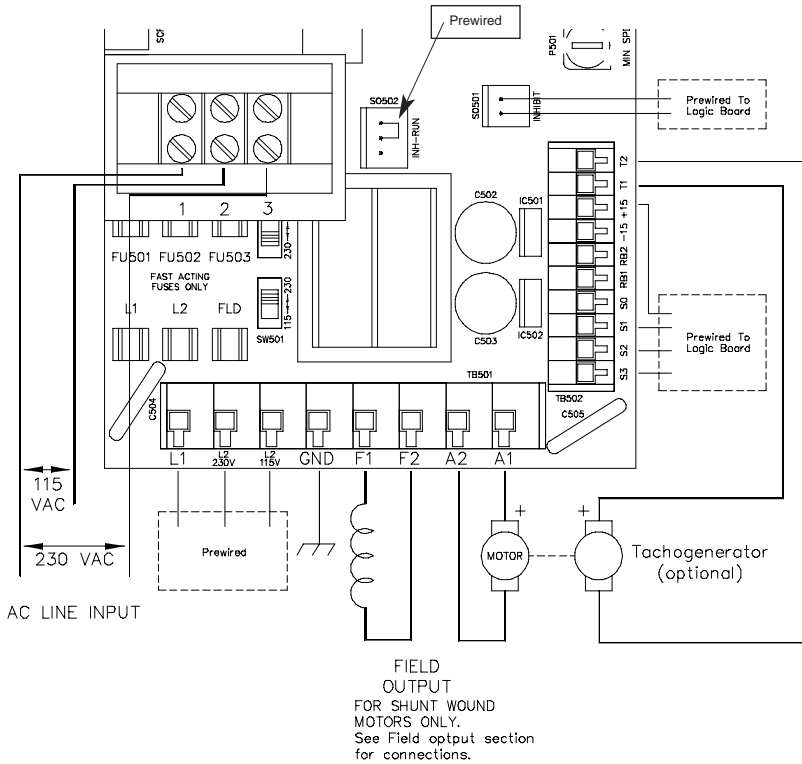

Figure 5. Connections

Assumptions: Minarik® drives supply motor voltage from the A1 and A2 terminals. It is assumed throughout this manual that, when A1 is positive with respect to A2, the driven motor will rotate clockwise (CW) while looking at the output shaft protruding from the front of the motor. If the opposite is desired, simply reverse the wiring of A1 and A2 with each other.

⚠ Minarik® assumes that the user has selected proper line-balancing and/or power factor correction circuitry.

Field output

The field output is for shunt wound motors only. **Do not make any connections to the field output when using a permanent magnet motor.** See Table 2 for field output connections.

Table 2. Field Output Connections

Line Voltage (VAC)	Approximate Field Voltage (VDC)	Field Connections
115	50	F1 and L1
115	100	F1 and F2
230	100	F1 and L1
230	200	F1 and F2

Limit switch connections (optional)

All connections to the logic board are prewired (see prewired connections on page 29). If your application requires the use of limit switches, connect the limit switches to the logic board as shown in Figure 6. If only the forward limit switch is used, remove the reverse limit switch and jumper terminal 21 to 22. If only the reverse limit switch is used, remove the forward limit switch and jumper terminal 20 to 22.

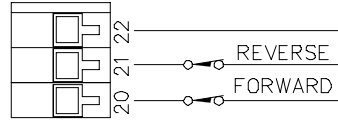

Figure 6. Optional limit switch connections

Remote pushbuttons (optional)

Add external jog, stop, reverse and forward pushbuttons to control the drive from a remote location. Connect normally open pushbuttons to top board terminals 15 through 19 (see Figure 7). Case pushbuttons may still be used if external pushbuttons are connected.

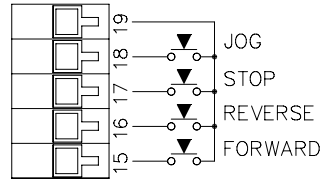

Figure 7. Optional remote pushbutton connections

Slide switches

Set all slide switches to their proper setting before applying power (see Figure 8).

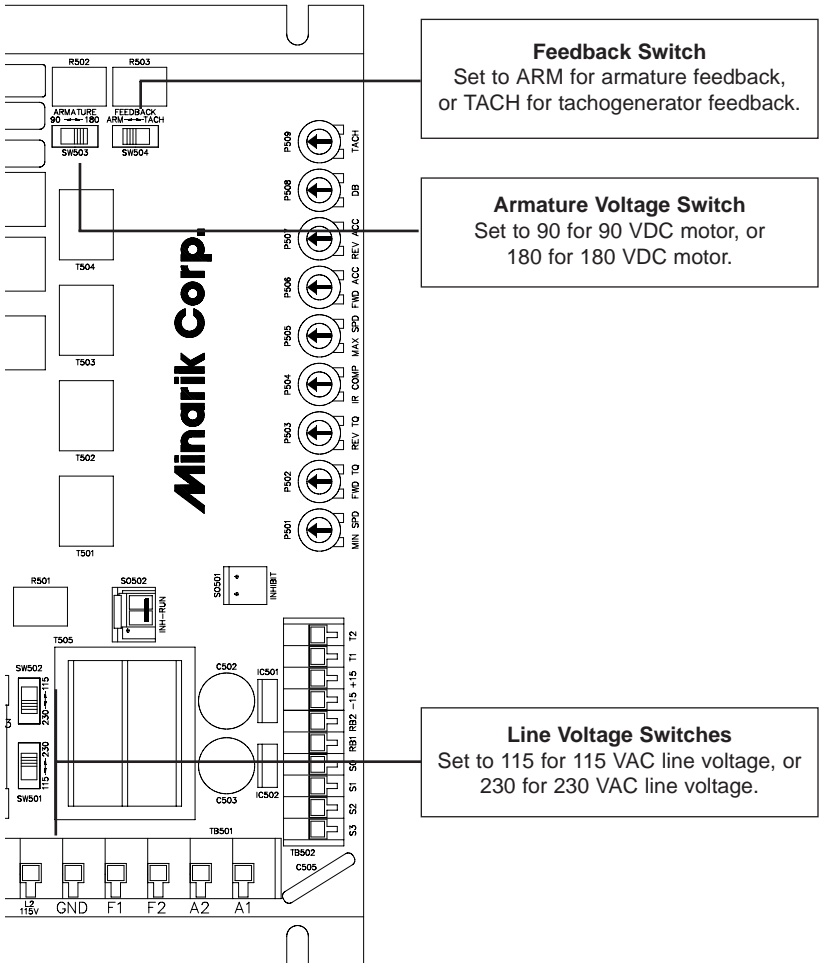

Figure 8. Slide Switches

Mode select switches

Mode select switches, located on the logic board (see Figure 9), are preset with switch 1 OFF and switch 2 ON. This allows you to operate the drive without the use of limit switches. Change mode select switch settings when power is off. Make sure that terminals 20, 21, and 22 are jumpered if limit switches are not used. If limit switches are used, set the mode select switches to one of the four operating modes:



Mode 1 (1 and 2 OFF) – Half cycle between forward and reverse limit switches.



Mode 2 (1 ON and 2 OFF) – Single cycle between forward and reverse limit switches.



Mode 3 (1 OFF and 2 ON) – Continuous cycle between forward and reverse limit switches.



Mode 4 (1 and 2 ON) – Single cycle with one limit switch.

See page 14 for more information on limit switch operating modes.

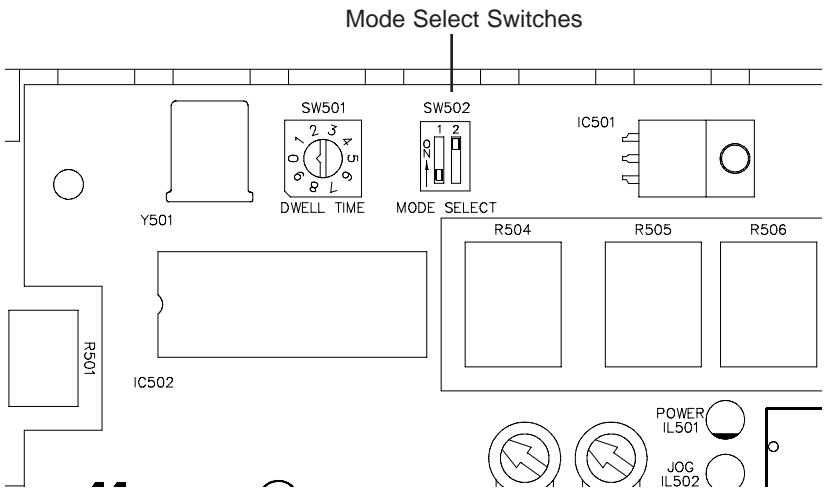

Figure 9. Mode Select Switches

Operation

⚠ Before applying power

- Verify that no conductive material is present on the printed circuit board.
- Set all switches to their proper settings.
- Verify that the AC supply is properly balanced.

Startup

1. Set the power switch to **0** (off); set forward and reverse speed adjust potentiometers to 0; set FWD JOG and REV JOG trimpots to 50% (12 o'clock).
2. Apply AC line voltage.
3. Set the power switch to **I** (on). The LED above is lit.
3. To rotate the motor in the forward direction:
 - a. Press . The LED above it lights.
 - b. Set the forward speed adjust potentiometer until the motor rotates at the desired forward speed.

To rotate the motor in the reverse direction:

- a. Press . The LED above it lights.
 - b. Set the reverse speed adjust potentiometer until the motor rotates at the desired reverse speed.
5. To switch the direction of motor rotation, press the pushbutton of the opposite direction.
 6. Press to stop the motor.

Jogging the motor

The RG501A and RG511A has a jog option, allowing you to jog the motor in the forward or reverse direction as long as the forward or reverse pushbutton is pressed. The drive can be switched to the jog mode while the motor is stopped, or is running in either the forward or reverse direction.

To jog the motor:

1. Press to enter the jog mode.
2. To jog the motor in the forward direction:
 - a. Press and hold the pushbutton. The motor jogs in the forward direction. The motor speed is set by the FWD JOG trimpot.
 - b. Release to stop the motor.







To jog the motor in the reverse direction:



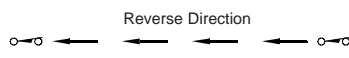

- a. Press and hold the pushbutton. The motor jogs in the reverse direction. The motor speed is set by the REV JOG trimpot.
 - b. Release to stop the motor.
3. To exit the jog mode, press .

Limit switch operating modes

The following is a description of the four limit switch operating modes.



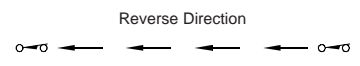

Mode 1 – Half cycle between forward and reverse limit switches

1. Press the forward pushbutton for forward motor rotation.	Press  to go forward.
2. Motor rotates in the forward direction until the forward limit switch opens.	
3. The motor stops when the forward limit switch opens.	
4. Press the reverse pushbutton for reverse motor rotation	Press  to go reverse.
5. Motor rotates in the reverse direction until the reverse limit switch opens.	
6. The motor stops when the reverse limit switch opens. Return to step 1 to repeat the process	



1. Press the forward pushbutton for forward motor rotation.	Press  to go forward.
2. Motor rotates in the forward direction until the forward limit switch opens.	
3. The motor stops and dwells when the forward limit switch opens. Set the dwell time by calibrating the DWELL TIME trimpot (see page 23).	
4. Motor rotates in the reverse direction until the reverse limit switch opens.	
5. The motor stops when the reverse limit switch opens. Return to step 1 to repeat the process.	

- Single cycle automatically returns travel to the reverse limit switch location.

Mode 3 – Continuous cycle between forward and reverse limit switches

<p>1. Press the forward pushbutton for forward motor rotation.</p>	<p>Press FWD to go forward.</p>
<p>2. Motor rotates in the forward direction until the forward limit switch opens.</p>	<p>Reverse Limit Switch Forward Direction Forward Limit Switch</p> 
<p>3. The motor stops and dwells when the forward limit switch opens. Set the dwell time by calibrating the DWELL TIME trimpot (see page 23).</p>	<p>STOP AND DWELL</p> 
<p>4. Motor rotates in the reverse direction until the reverse limit switch opens.</p>	<p>Reverse Direction</p> 
<p>5. The motor stops and dwells when the reverse limit switch opens. The process repeats steps 2-5 until you press the STOP pushbutton.</p>	<p>STOP AND DWELL</p> 

Mode 4 – Single cycle with one limit switch

<p>1. Press the forward pushbutton for forward motor rotation.</p> <p style="text-align: center;">OR</p> <p>Press the reverse pushbutton for reverse motor rotation.</p>	<p>Press FWD to go forward,</p> <p style="text-align: center;">OR</p> <p>Press REV to go reverse.</p>
<p>2. Motor rotates until the limit switch opens.</p>	<p>Limit Switch</p> 
<p>3. The motor stops when the limit switch is open. Return to step 1 to restart the motor.</p>	<p>STOP</p> 

Note:

For all operating modes, press the **STOP** pushbutton to stop a rotating motor before a limit switch is activated. Resume operation by pressing the **FORWARD** or **REVERSE** pushbuttons.

Warnings

Regenerative braking (by pressing the STOP pushbutton) is recommended for frequent stops. Do not use this method for emergency stopping. It may not stop a drive that is malfunctioning. **Removing AC line power (both L1 and L2) is the only acceptable method for emergency stopping.**

Frequent regenerative braking produces high torque. This may cause damage to motors, especially gearmotors, that are not properly sized for the application.

If 230 VAC line voltage is used, it must be balanced. Contact your local distributor for power factor correction circuitry and line balancing circuitry.

Calibration

Each drive is factory calibrated to its maximum horsepower rating. Readjust the calibration trimpot settings to accommodate lower horsepower motors.

All adjustments increase with clockwise (CW) rotation, and decrease with counterclockwise CCW rotation. Use a non-metallic screwdriver for calibration. Each trimpot is identified on the printed circuit board.

Power board trimpots

MIN SPD

MIN SPD may be calibrated if the CCW side of the speed adjust potentiometer is connected to S0 (S0 is in series with the MIN SPD trimpot). Since the forward and reverse speed adjust potentiometers are not connected to S0, MIN SPD cannot be calibrated.

MAX SPD

The MAX SPD trimpot setting determines the motor speed when the forward (or reverse) speed adjust potentiometer is turned full CW. It is factory set for maximum rated speed.

To calibrate MAX SPD:

1. Set the MAX SPD trimpot full CCW.
2. Press (or).
3. Turn the forward (or reverse) speed adjust potentiometer full CW.
4. Adjust the MAX SPD trimpot until the desired maximum motor speed is reached.

The calibrated maximum speed is the same for both forward and reverse directions.

FWD ACC

The FWD ACC trimpot setting determines the time the motor takes to ramp to either a higher speed in the forward direction or a lower speed in the reverse direction, within the limits of available torque. FWD ACC is factory set for its fastest forward acceleration time.

Turn the FWD ACC trimpot CW to increase the forward acceleration time and reverse deceleration time, and CCW to decrease the forward acceleration time and reverse deceleration time.

REV ACC

The REV ACC trimpot setting determines the time the motor takes to ramp to either a higher speed in the reverse direction or a lower speed in the forward direction, within the limits of available torque. REV ACC is factory set for its fastest reverse acceleration time.

Turn the REV ACC trimpot CW to increase the reverse acceleration time and forward deceleration time, and CCW to decrease the reverse acceleration time and forward deceleration time.

IR COMP

The IR COMP trimpot setting determines the degree to which motor speed is held constant as the motor load changes. It is factory set for optimum motor regulation.

To calibrate IR COMP (exact calibration):

1. With the motor rotating in the forward direction, set the forward speed adjust potentiometer until the motor runs at midspeed (for example, 900 RPM for an 1800 RPM motor).
2. Load the motor armature to its full load armature current rating. The motor should slow down.
3. While keeping the load on the motor, rotate the IR COMP trimpot until the motor runs at the speed measured in step 1.

Approximate calibration:

If the motor does not maintain set speed as the load changes, gradually rotate the IR COMP trimpot CW. If the motor oscillates (overcompensation), the IR COMP trimpot may be set too high (CW). Turn the IR COMP trimpot CCW to stabilize the motor speed.

See Figures 10 and 11 for recommended IR COMP trimpot settings.

FWD TQ

The FWD TQ setting determines the maximum torque for accelerating and driving the motor in the forward direction. It also sets the maximum torque for decelerating the motor from the reverse direction. FWD TQ is factory set at 120% of rated motor current.

To recalibrate FWD TQ, refer to the recommended FWD TQ settings on Figures 10 and 11, or recalibrate using the following procedure:

1. With the power disconnected from the drive, connect a DC ammeter in series with the armature.
2. Set the FWD TQ trimpot to minimum (full CCW).
3. Lock the motor armature. Be sure that the motor is firmly mounted.
4. Connect power to the drive. The motor should remain stopped.
5. Press .
6. Set the forward speed adjust potentiometer for maximum forward speed.
7. Adjust the FWD TQ trimpot CW until the armature current is 120% of motor rated current.
8. Set the forward speed adjust potentiometer to minimum and remove the stall from the motor.

REV TQ

The REV TQ trimpot setting determines the maximum torque for accelerating and driving the motor in the reverse direction. It also sets the maximum torque for decelerating the motor from the forward direction. REV TQ is factory set at 120% of rated motor current.

To recalibrate REV TQ, refer to the recommended REV TQ settings on Figures 10 and 11, or recalibrate using the following procedure:

1. With the power disconnected from the drive, connect a DC ammeter in series with the armature.
2. Set the REV TQ trimpot to minimum (full CCW).
3. Lock the motor armature. Be sure that the motor is firmly mounted.
4. Connect power to the drive. The motor should remain stopped.
5. Press REV .
5. Set the reverse speed adjust potentiometer for maximum reverse speed.
6. Adjust the REV TQ trimpot CW until the armature current is 120% of motor rated current.
7. Set the reverse speed adjust potentiometer to minimum and remove the stall from the motor.

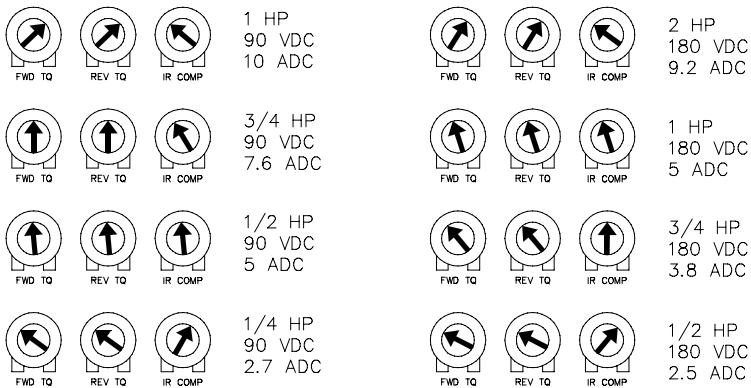

Figure 10. Recommended FWD TQ, REV TQ, and IR COMP Settings for RG501A (actual settings may vary with each application)

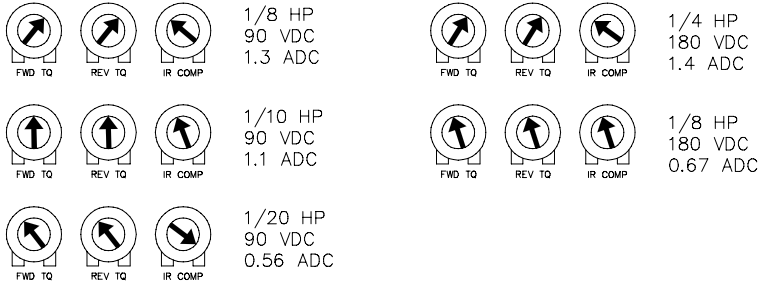

Figure 11. Recommended FWD TQ, REV TQ, and IR COMP Settings for RG511A (actual settings may vary with each application)

DB

The deadband trimpot setting determines the time that will elapse between the application of current in one direction before current is applied in the opposite direction. It also affects the resistance that a motor has to changes in shaft position at zero speed by applying AC voltage to the motor armature.

Deadband is factory calibrated to approximately the 3 o'clock position for 60 Hz AC line operation. Recalibrate the deadband to the 9 o'clock position for 50 Hz AC line operation. If you hear motor noise (a humming or buzzing sound), the deadband might be set too high. Turn the deadband trimpot CCW until the motor noise ceases. See Figure 12 for recommended deadband settings.

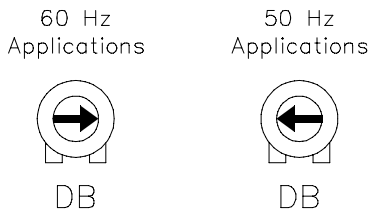



Figure 12. Deadband Settings

⚠ Warning Do not turn DB past the 60 HZ setting. This could cause shoot thru, which may blow fuses and cause the drive to fail.

TACH (for use with tachogenerator feedback only)

Calibrate the TACH trimpot setting only when a tachogenerator is used. The TACH setting, like the IR COMP setting, determines the degree to which motor speed is held constant as the motor load changes.

To calibrate the TACH:

1. Connect the tachogenerator to T1 and T2. The polarity is “+” for T1 and “-” for T2 when the motor is running in the forward direction.
2. Set switch 504 (SW504) to ARM for armature feedback.
3. Set the power switch to **I** (on).
4. Press .
3. Set the forward speed adjust potentiometer full CW. Measure the armature voltage across A1 and A2 using a voltmeter.
4. Set the speed adjust potentiometer to 0 (zero speed).
5. Set SW504 to TACH for tachogenerator feedback.
6. Set the IR COMP trimpot full CCW.
7. Set the TACH trimpot full CW.
8. Set the speed adjust potentiometer full CW.
9. Adjust the TACH trimpot until the armature voltage is the same value as the voltage measured in step 3.

Check that the tachogenerator is properly calibrated. The motor should run at the same set speed when SW504 is set to either armature or tachogenerator feedback.

Logic board trimpots**FWD JOG**

The FWD JOG trimpot setting determines the motor speed when it rotates in the forward direction in the jog mode. To calibrate FWD JOG:

1. Press .
2. Press and hold the pushbutton. The motor jogs in the forward direction.
3. Adjust the FWD JOG trimpot until the motor rotates at the desired forward jog speed.
4. Release to stop the motor.

REV JOG

The REV JOG trimpot setting determines the motor speed when it rotates in the reverse direction in the jog mode. To calibrate REV JOG:

1. Press .
2. Press and hold the pushbutton. The motor jogs in the reverse direction.
3. Adjust the REV JOG trimpot until the motor rotates at the desired reverse jog speed.
4. Release to stop the motor.

DWELL TIME

The DWELL TIME trimpot setting determines the length of time the motor stops before rotating in the opposite direction. DWELL TIME only works when the drive is set for Mode 2 and Mode 3 (see page 14 for limit switch operating modes).

There are 10 DWELL TIME settings (0 thru 9). Set the DWELL TIME to 0 (the factory setting) for 0.1 second delay. Increasing the setting one increment higher adds 0.1 second to the dwell time. Set the DWELL TIME trimpot to 9 for approximately 1 second delay.

Troubleshooting

Warning

 Dangerous voltages exist on the drive when it is powered. When possible, disconnect the drive while troubleshooting. High voltages can cause serious or fatal injury.

Check the following steps before proceeding:

1. The AC line voltage must be balanced, and match the voltage on the drive nameplate.
2. Check that all switches are set to the correct positions.
3. The deadband (DB) trimpot must be set approximately at the 3 o'clock position for 60 Hz AC line frequency or at 9 o'clock for 50 Hz AC line frequency.
4. The motor must be rated for the drive's rated armature (all motors) and field outputs (shunt wound motors only).
5. Do not make any connections to F1 and F2 if using a permanent magnet motor.
6. Terminal block connections should be consistent with the connections shown in this manual.
7. Check that line fuses FU501 and FU502 are properly sized and not blown.
8. Check that field fuse FU503 is 1.5 A and not blown.

Problem	Possible Causes	Suggested Solutions
Field fuse blows	<ol style="list-style-type: none"> 1. Field fuse is the wrong size. 2. Motor field is shorted to ground. 3. F1 is shorted to F2. 4. Motor cable is shorted to ground. 5. Motor field leads are reversed with motor armature. 	<ol style="list-style-type: none"> 1. Verify that the fuse is 1.5 A. 2. Check if the motor field is shorted to ground. Replace motor if necessary. 3. Check that F1 and F2 are not shorted together. 4. Check that the motor cable is not shorted to ground. Replace cable if necessary. 5. Wire motor armature to A1 and A2; wire motor field to F1 and F2.
Line fuse blows	<ol style="list-style-type: none"> 1. Line fuses are the wrong size. 2. Motor cable or armature is shorted to ground. 3. Nuisance tripping caused by a combination of ambient conditions and high-current spikes (i.e. reversing). 4. Field circuit is open. 	<ol style="list-style-type: none"> 1. Check that line fuses are properly sized. 2. Check motor cable and armature for shorts. 3. Add a blower to cool the drive components; decrease FWD TQ and REV TQ settings; check wiring to be sure noise is reduced or eliminated. 4. Send in drive to Minarik repair department.
Motor runs too fast at maximum speed setting	<ol style="list-style-type: none"> 1. MAX SPD setting is too high. 2. Motor field connections are loose (shunt wound motors only). 	<ol style="list-style-type: none"> 1. Recalibrate MAX SPD. 2. Check motor field connections.

Problem	Possible Causes	Suggested Solutions
<p>Line fuse does not blow, but the motor does not run when the forward or reverse pushbutton is pressed</p>	<ol style="list-style-type: none"> 1. Forward or reverse speed adjust potentiometer is set to zero speed. 2. Forward or reverse speed adjust potentiometer is not connected to drive input properly; connections are open. 3. Middle and right INH-RUN terminals are not jumpered. 4. INHIBIT terminals are jumpered. 5. S2 is shorted to S0. 6. Drive is in current limit. 7. Drive is not receiving AC line voltage. 8. Motor is not connected. 9. Touch panel, logic board, or power board connections might be loose. 	<ol style="list-style-type: none"> 1. Increase the forward or reverse speed adjust potentiometer setting 2. Check connections to input. Verify that connections are not open. 3. Jumper middle and right INH-RUN terminals. 4. Remove jumper from INHIBIT terminal. 5. Remove short. 6. Verify if motor is jammed. Increase FWD TQ or REV TQ setting if they are set too low. 7. Apply AC line voltage to L1 and L2. 8. Connect motor to A1 and A2. 9. Check all connections.
<p>Motor runs too slow or too fast</p>	<ol style="list-style-type: none"> 1. Switches set incorrectly. 2. MAX SPD is not calibrated. 3. Motor field not properly connected (shunt wound motors only) 	<ol style="list-style-type: none"> 1. Verify all switch settings. 2. Calibrate MAX SPD. 3. Verify motor field connections.

Problem	Possible Causes	Suggested Solutions
Motor will not reach the desired speed	1. MAX SPD setting is too low. 2. IR COMP setting is too low. 3. Motor is overloaded.	1. Increase MAX SPD setting. 2. Increase the IR COMP setting. 3. Check motor load. Resize the motor if necessary.
Motor pulsates or surges under load	1. IR COMP is set too high. 2. Motor “bouncing” in and out of torque limit.	1. Adjust the IR COMP setting slightly CCW until the motor speed stabilizes. 2. Make sure motor is not undersized for load; adjust FWD TQ and REV TQ trimpots.
Motor does not reverse	Touch panel, logic board, or power board connections might be loose.	Check all connections.
Motor makes a humming or buzzing noise	Deadband setting is too high.	Turn deadband (DB) trimpot CCW until the noise stops.
FWD or REV JOG speed is too slow or too fast	FWD or REV JOG speed not calibrated.	Calibrate FWD JOG and REV JOG trimpots (see Calibration section).

For additional assistance, contact your local Minarik® Distributor, or the factory direct: phone (818) 502-1528; fax (818) 502-0716.

Block Diagram

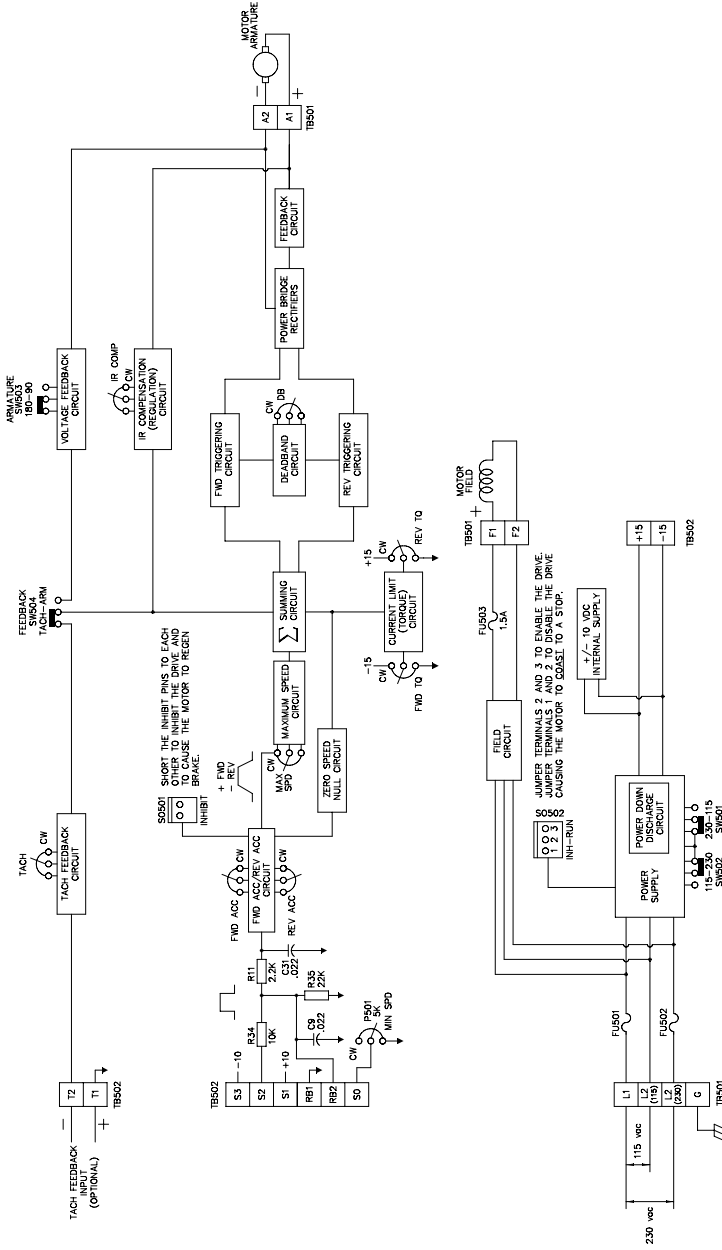

Figure 13. RG501A and RG511A Block Diagram

Prewired Connections

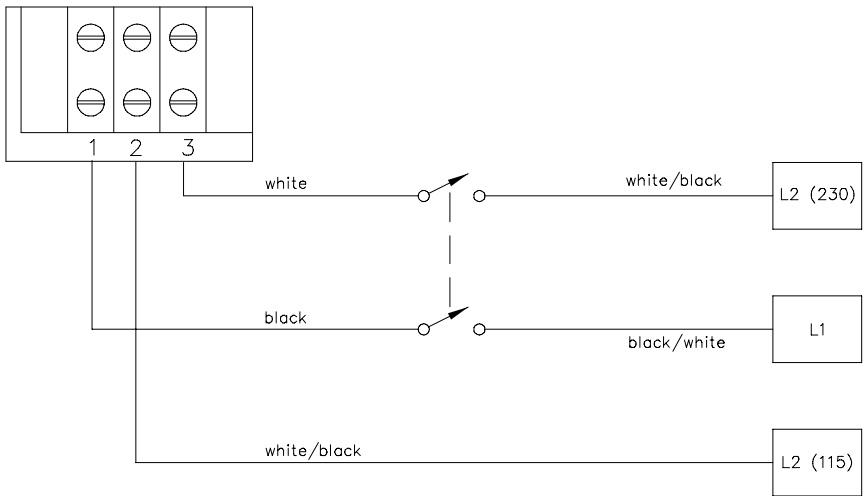

Figure 14. Prewired Connections to L1, L2 (115) and L2 (230)

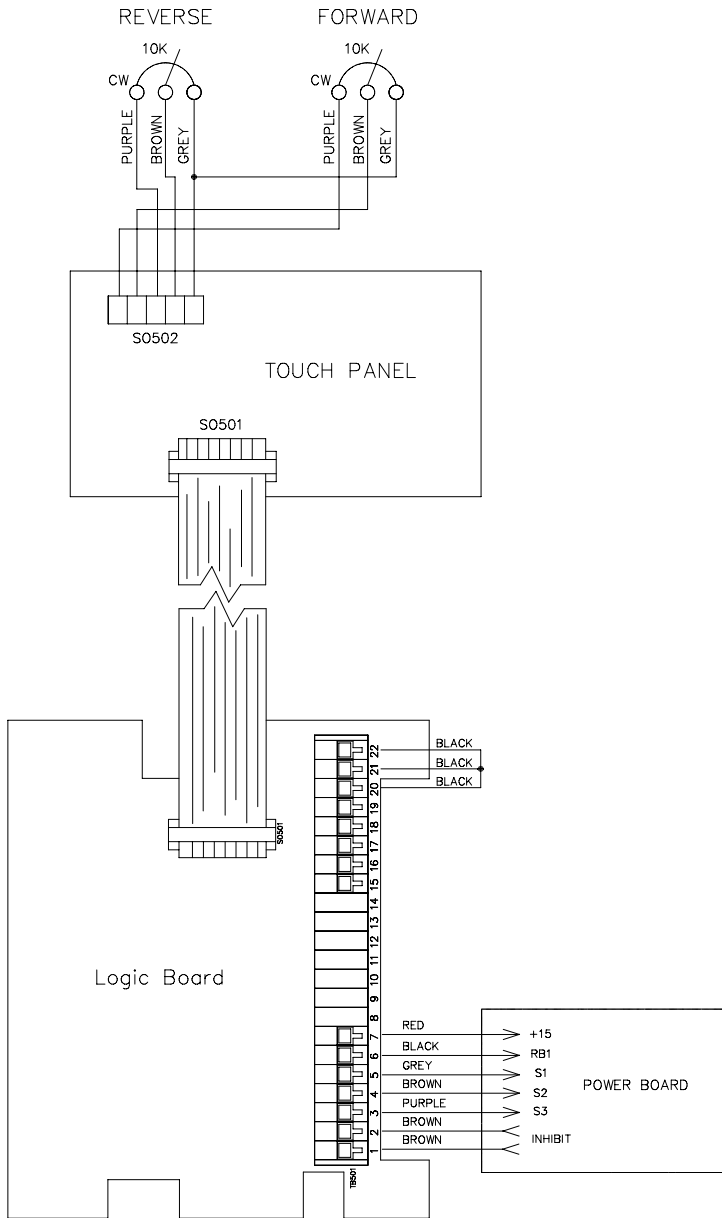

Figure 15. Touch Panel, Logic Board, and Power Board Connections

Replacement Parts

Replacement parts are available from Minarik Corporation and its distributors for this drive series.

Table 3. Replacement Parts

Model No.	Symbol	Description	Minarik P/N
RG501A	R501	0.01 Ω , 5 W Resistor	032-0129
	SCR501-508	800 V, 25 A SCR	072-0042
	T505	3FD-436 Transformer	230-0072
		20 A, 3AB Line Fuse	050-0019
		1.5 A, 3AG Field Fuse	050-0026
		10K Ω , 1/2 W Potentiometer	120-0047
		Potentiometer Knob	140-0013
		Case	223-0297
		Power Switch	080-0003
		Toggle Switch Boot	155-0078
		Chassis	223-0260
		Heat Sink	223-0232
		Ribbon Cable	134-0037
	RG511A	R501	0.1 Ω , 5 W Resistor
SCR501-508		800 V, 25 A SCR	072-0042
T505		3FD-436 Transformer	230-0072
		8 A, 3AB Line Fuse	050-0023
		10K Ω , 1/2 W Potentiometer	120-0047
		1.5 A, 3AG Field Fuse	050-0026
		Potentiometer Knob	140-0013
		Case	223-0297
		Power Switch	080-0003
		Toggle Switch Boot	155-0078
		Chassis	223-0260
		Heat Sink	223-0232
		Ribbon Cable	134-0037
Fuse Kits			3–8A Fuse Kit (with 1/2A pico fuse)
		5–20A Fuse Kit (with 1/2A pico fuse)	050-0073
	F504	1/2A Pico Fuse	050-0074

Certificate of Compliance

Minarik Corporation hereby certifies that its RG501A drive has been approved to bear the “CE” mark provided the conditions of approval have been met by the end user.

The RG501A has been tested to the following test specifications:

EN55011:1991 (emissions), and EN50082-1:1992 (immunity)

Compliance allows the RG501A to bear the CE mark.

The end user, as described herein, falls into one of two categories:

1. The Consumer will deploy a stand-alone unit as an integral, yet external, portion of the machine being operated.
2. The Original Equipment Manufacturer (OEM) will implement the product as a component of the machine being manufactured.

AC Line Filters

In addition to EMI/RFI safeguards inherent in the RG501A design, external filtering is required.

Minarik requires the Corcom® AC line filters listed in Table 4. Use model 5VR1 with drives rated for 3 ADC or below, and model 20VV1 with drives rated for 10 ADC or below.

Table 4. AC Line Filters

Corcom® Model Number	5VR1	20VV1
Rated Current	5 A	20 A
Inductance	1.032 mH	0.88 mH
Capacitance		
Line to Line	0.303 μ F	0.303 μ F
Line to Ground	0.011 μ F	0.011 μ F
Discharge Resistor	680 K Ω	680 K Ω

Wire the AC line filter within 0.25 meters of the drive. The ground connection from the filter must be wired to solid earth ground (resistance less than 500 ohms); not machine ground. This is very important!



If the end-user is using a CE-approved motor, the correct filter from Table 4 is all that is necessary to meet the EMC directives listed herein.

Armature Filters

If the end-user is not using a CE-approved motor, a filter on the armature must also be used. See Table 5 for recommended armature filters. Use model CE04RG with drives rated for 3 ADC or below, and model CE10RG with drives rated for 10 ADC or below.

Table 5. Armature Filters

Minarik® Model Number	CE04RG	CE10RG
Rated Current	4 A	10 A
Inductance		1200 mH
Capacitance (C1 and C2)	0.1 μ F @ 400W VDC	
Discharge Resistor	680K Ω	

Wire the armature filter to the DC output of the drive, as close to the drive as possible. The ground connection from the filter must be wired to solid earth ground (resistance less than 500 ohms); not machine ground. This is very important!

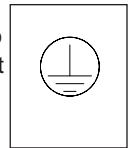

The end user must use the filtration listed in this addendum to comply with CE. The OEM may choose to provide alternative filtering that encompasses the Minarik drive and other electronics within the same panel. The OEM has this liberty because CE is a machinery directive.

Whether or not every component in the OEM's machinery meets CE, the OEM must still submit his machine for CE approval. Thus, no component must necessarily meet CE within the machine, as long as the OEM takes the necessary steps to guarantee the machine does meet CE. By the same token, even if every component in the OEM's machine does meet CE, the machine will not necessarily meet CE as a machine.

Using CE-approved wiring practices (like proper shielding) and the filters should assure the drive will meet EN55014 (1993 emissions standard) and EN50082-1 (1992 immunity standard).

Notes

Notes

Limited Warranty

A. Warranty - Minarik Corporation (referred to as “the Corporation”) warrants that its products will be free from defects in workmanship and material for two (2) years from date of shipment thereof, or 6,000 hours, whichever comes first. Within this warranty period, the Corporation will repair or replace such products that are: (1) returned to Minarik Corporation, 901 East Thompson Avenue, Glendale, CA 91201-2011 U.S.A.; and, (2) determined by the Corporation to be defective.

This warranty shall not apply to any product that has been subject to misuse, negligence, or accident; or misapplied; or repaired by unauthorized persons; or improperly installed. The Corporation is not responsible for removal, installation, or any other incidental expenses incurred in shipping the product to and from the repair point.

B. Disclaimer - The provisions of Paragraph A are the Corporation’s sole obligation and exclude all other warranties of merchantability for use, express or implied. The Corporation further disclaims any responsibility whatsoever to the customer or to any other person for injury to the person or damage or loss of property of value caused by any product that has been subject to misuse, negligence, or accident, or misapplied or modified by unauthorized persons or improperly installed.

C. Limitations of Liability - In the event of any claim for breach of any of the Corporation’s obligations, whether express or implied, and particularly of any other claim or breach of warranty contained in Paragraph A, or of any other warranties, express or implied, or claim of liability that might, despite Paragraph B, be decided against the Corporation by lawful authority, the Corporation shall under no circumstances be liable for any consequential damages, losses, or expense arising in connection with the use of, or inability to use, the Corporation’s product for any purpose whatsoever.

An adjustment made under warranty does not void the warranty, nor does it imply an extension of the original two (2) year or 6,000 hour warranty period. Products serviced and/or parts replaced on a no-charge basis during the warranty period carry the unexpired portion of the original warranty only.

If for any reason any of the foregoing provisions shall be ineffective, the Corporation’s liability for damages arising out of its manufacture or sale of equipment, or use thereof, whether such liability is based on warranty, contract, negligence, strict liability in tort, or otherwise, shall not in any event exceed the full purchase price of such equipment.

Any action against the Corporation based upon any liability or obligation arising hereunder or under any law applicable to the sale of equipment or the use thereof, must be commenced within one year after the cause of such action arises.

Other drives from Minarik Corporation:



RGT Series

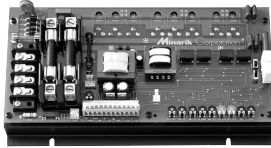

RG5500U



MMRG Series



BOSS Series

Minarik Automation
& Control

901 East Thompson Avenue
Glendale, California 91201-2011

Phone: (818) 502-1528

Fax: (818) 502-0716

www.minarikcorp.com

Document number 250-0234, Revision 1

Printed in the U.S.A – 1/98

\$11.00 North America – \$12.00 Outside North America