

## Instructions for Use

### Models MM31700B/MM31701B/ MM31750B/MM31751B

## Specifications

Line Voltage	115 VAC (-5%, +10%), 60 Hz
Horsepower Range	
MM31700B/MM31750B	1/8 – 1/4 HP
MM31701B/MM31751B	1/50 – 1/10 HP
Armature Voltage Range	0 – 90 VDC
Ambient Temperature Range	10°C – 55°C

Models MM31700B and MM31701B are supplied with a 6-wire harness assembly and a 10K ohm single turn speed adjust potentiometer as separate components packed with the drive. Models MM31750B and MM31751B have the speed adjust potentiometer mounted on the board support bracket and include a 4-wire harness packed with the drive.

# Dimensions

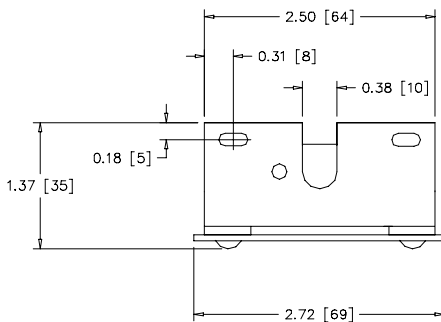
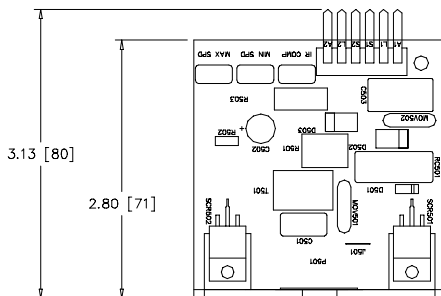

ALL DIMENSIONS IN INCHES [MILLIMETERS]

Figure 1. MM31700B/MM31701B Dimensions



## **⚠ Safety Warnings**

- Have a qualified electrical maintenance technician install, adjust, and service this equipment. Follow the National Electrical Code (NEC) and all other applicable electrical and safety codes, including the provisions of the Occupational Safety and Health Act (OSHA) when installing equipment.
- Reduce the chance of an electrical fire, shock, or explosion by proper grounding, over current protection, thermal protection, and enclosure. Follow sound maintenance procedures.
- It is possible for a drive to run at full speed as a result of a component failure. Install a master switch in the AC line for stopping the drive in an emergency.
- This drive is not isolated from earth ground. Circuit potentials are at 115 VAC above earth ground. Avoid direct contact with the printed circuit board or with circuit elements to prevent the risk of serious injury or fatality. Use a non-metallic screwdriver for adjusting the calibration trimpots.

## **Fusing**

Minarik recommends fusing the drive. Use a fast acting fuse rated for 250 volts, and approximately 150%–200% of the maximum armature current. Fuse only the “hot” side of the AC line (L1).

# Connections

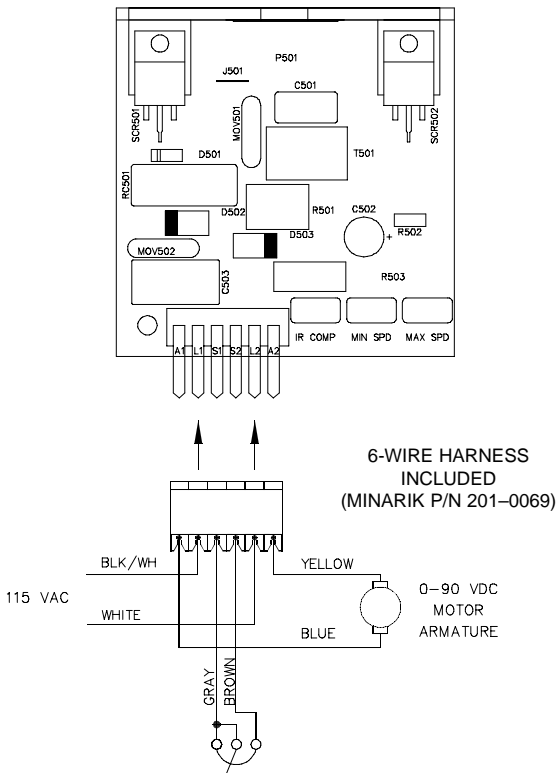

Figure 3. MM31700B/MM31701B Connections

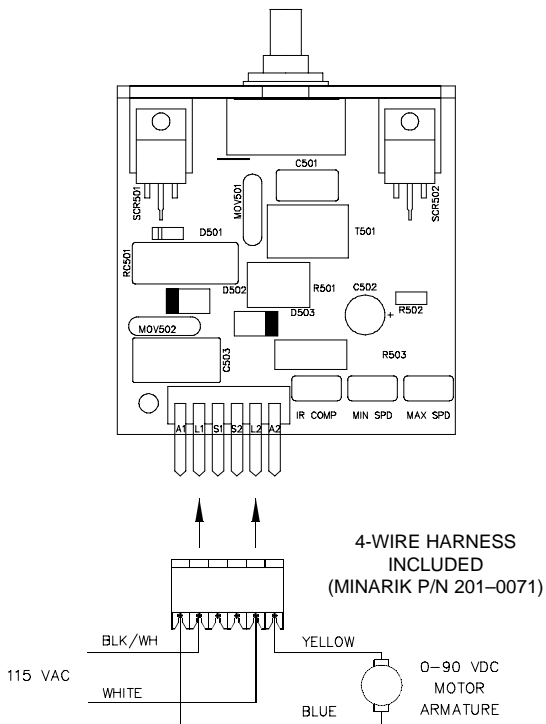

Figure 4. MM31750B/MM31751B Connections

## Startup

1. Turn the speed adjust potentiometer full counterclockwise (CCW).
2. Apply 115 VAC line voltage to L1 and L2.
3. Slowly advance the speed adjust potentiometer clockwise (CW). The motor slowly accelerates as the potentiometer is turned CW. Continue until the desired speed is reached.
4. Remove the 115 VAC line voltage from the drive to coast the motor to a stop.

## Calibration

Each drive is factory calibrated to its maximum horsepower rating. Readjust the calibration trimpot settings to accommodate lower horsepower motors. Use a non-metallic screwdriver for calibration.

### MIN SPD

The MIN SPD setting determines the motor speed when the speed adjust potentiometer is turned full CCW. To calibrate, turn the speed adjust potentiometer full CCW. Adjust the MIN SPD trimpot until the motor has stopped, or is running at the desired speed.

## **MAX SPD**

The MAX SPD setting determines the motor speed when the speed adjust potentiometer is turned full clockwise. To calibrate, set the MAX SPD trimpot full counterclockwise. Turn the speed adjust potentiometer full CW. Adjust the MAX SPD trimpot until the maximum motor speed is reached.

## **IR COMP**

The IR COMP setting the degree to which the motor speed is held constant as the motor load changes. If the motor does not maintain set speed as the load changes, gradually rotate the IR COMP trimpot CW. If the motor speed oscillates (overcompensation), the IR COMP may be set too high. Turn the IR COMP trimpot CCW to stabilize the motor speed.



901 East Thompson Avenue  
Glendale, California 91201-2011  
Phone: (818) 502-1528  
Fax: (818) 502-0716

Document Number 250-0231, Revision 0  
Printed in the U.S.A -9/96  
U.S.A. \$2.00, Outside U.S.A. \$3.00