

BOSS Series



Models:

BOSS04-115AC-1Q

BOSS08-115AC-1Q

BOSS15-115AC-1Q

Copyright ©2001 by
Minarik Corporation

All rights reserved. No part of this manual may be reproduced or transmitted in any form without written permission from Minarik Corporation. The information and technical data in this manual are subject to change without notice. Minarik Corporation and its Divisions make no warranty of any kind with respect to this material, including, but not limited to, the implied warranties of its merchantability and fitness for a given purpose. Minarik Corporation and its Divisions assume no responsibility for any errors that may appear in this manual and make no commitment to update or to keep current the information in this manual.

Printed in the United States of America

Safety Warnings



- This symbol  denotes an important safety tip or warning. Please read these instructions carefully before performing any of the procedures contained in this manual.
- Have a qualified electrical maintenance technician install, adjust, and service this equipment. Follow the National Electrical Code and all other applicable electrical and safety codes, including the provisions of the Occupational Safety and Health Act (OSHA) when installing equipment.
- Reduce the chance of an electrical fire, shock, or explosion by proper grounding, over current protection, thermal protection, and enclosure. Follow sound maintenance procedures.



Although the drive includes protective circuitry to prevent damage in the event of an accidental short circuit of the armature, it is not fail-safe. **It is possible for a drive to run at full speed as a result of a component failure.** Install a master switch in the drive's AC or DC voltage input line for stopping the drive in an emergency.

Inadvertent grounding of drive inputs could result in damage to the drive. Avoid direct contact with the printed circuit board or with circuit elements to prevent the risk of serious injury or fatality. Use a non-metallic screwdriver for adjusting the calibration trimpots. Use approved personal protective equipment and insulated tools if working on this drive with power applied.

Introduction

The BOSS series is a family of analog brushless servo controls. They are designed to be flexible and adaptable to a multitude of needs by using the “modular” concept. The modular concept has two parts: a motherboard and a daughter card. The motherboard contains power and motor connections. Each daughter card is designed to fit into the same motherboard, yet each daughter card is optimized for different applications. This allows you to customize your BOSS drive to suit your needs, unlike the standard “one size fits all” approach.

Contents

Specifications	1
Dimensions	2
Installation	4
Drive mounting	4
Wiring	5
Shielding guidelines	6
Fusing	7
Plug-in card mounting	8
Speed adjust potentiometer mounting	10
Quick-connect terminal block	11
Motherboard connections	12
Power connections	12
Line fusing	13
Motor connections	15
Regen dump circuit	16
Using the dump circuit with a DC power source	16
BOSS-1Q terminal descriptions	18
BOSS-1Q terminal connections	20
ENABLE/DISABLE switch	20
RUN/BRAKE switch	20
FWD/REV switch	20
Motor hall sensors	22
Voltage follower	24

Operation	25
Before applying power	25
Startup	26
To reverse motor direction:	26
Starting and stopping methods	27
To brake the motor	27
To coast the motor to a stop without disconnecting power	27
Line starting and line stopping	28
Calibration	29
Calibration procedure	31
MINIMUM SPEED (MIN SPD)	32
MAXIMUM SPEED (MAX SPD)	32
ACCELERATION (ACCEL)	33
DECELERATION (DECEL)	33
REGULATION	34
TORQUE LIMIT (TQ LIMIT)	35
Troubleshooting	36
Before troubleshooting	36
BOSS-1Q Diagnostic LEDs	37
Diagnostic LEDs on the BOSS-1Q plug-in card:	37
POWER ON	37
FAULT	37
Diagnostic LEDs on the motherboard:	37
BUS LIMIT	37
TQ LIMIT	37
Unconditional Warranty	inside back cover

Illustrations

Figure 1.	BOSS Series Dimensions2
Figure 2.	BOSS DB Regen Dump Circuit Dimensions3
Figure 3.	Plug-In Card Installation9
Figure 4.	Speed Adjust Potentiometer Mounting10
Figure 5.	Quick-Connect Terminal Plug11
Figure 6.	Motherboard Connections for (a) DC input voltage and (b) AC input voltage14
Figure 7.	Motherboard Connections for Three-Phase Motor15
Figure 8.	Regen Dump Circuit Connections17
Figure 9.	BOSS-1Q Terminal Connections21
Figure 10.	BOSS-1Q Sensor Connections23
Figure 11.	BOSS-1Q Voltage Signal Connections24
Figure 12.	BOSS-1Q Calibration Trimpot Layout30
Figure 13.	BOSS-1Q Diagnostic LED Location38

Tables

Table 1.	Recommended Line Fuse Sizes7
----------	---------------------------------------	----

Notes

Specifications

Drive	Maximum Phase Current (AC Amps)	AC Line Voltage Range	DC Input Voltage Range	Maximum Output Voltage (VAC)
BOSS04-115AC-1Q	4	90 - 130	100 - 180	130
BOSS08-115AC-1Q	8	90 - 130	100 - 180	130
BOSS15-115AC-1Q	15	90 - 130	100 - 180	130

AC Input Voltage Tolerance	$\pm 10\%$, 50 – 60 Hz
Maximum Phase Current Limit	1.5 times Maximum Phase Current (continuous)
Peak Phase Current Limit	2 times Maximum Phase Current (for 1 second)
Acceleration Time Range	0.5 – 6 seconds
Deceleration Time Range	0.5 – 6 seconds
Speed Range*	80:1
Speed Regulation (typical)	0.06% of base speed
Speed Adjust Potentiometer	10K ohms
Analog Input Voltage Range (signal must be isolated)	0 – 10 VDC
Input Impedance	60K ohms
Power Device Switching Frequency (6–step, trapezoidal)	22 kHz
Vibration	0.5G max (20 – 50 Hz) 0.1G max (>50 Hz)
Weight	2 lb
Ambient Operating Temperature Range	0 – 40° C

*Speed range is based on 8000 RPM motor. Minimum recommended speed is 100 RPM.

Dimensions

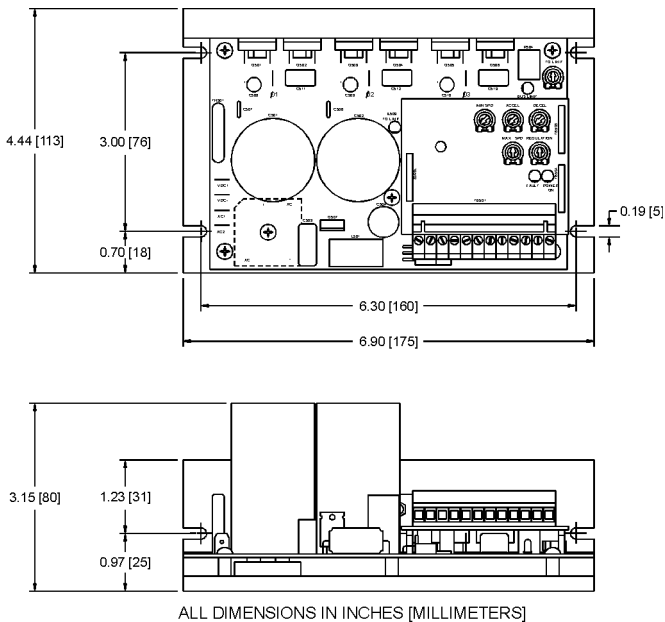

Figure 1. BOSS Series Dimensions

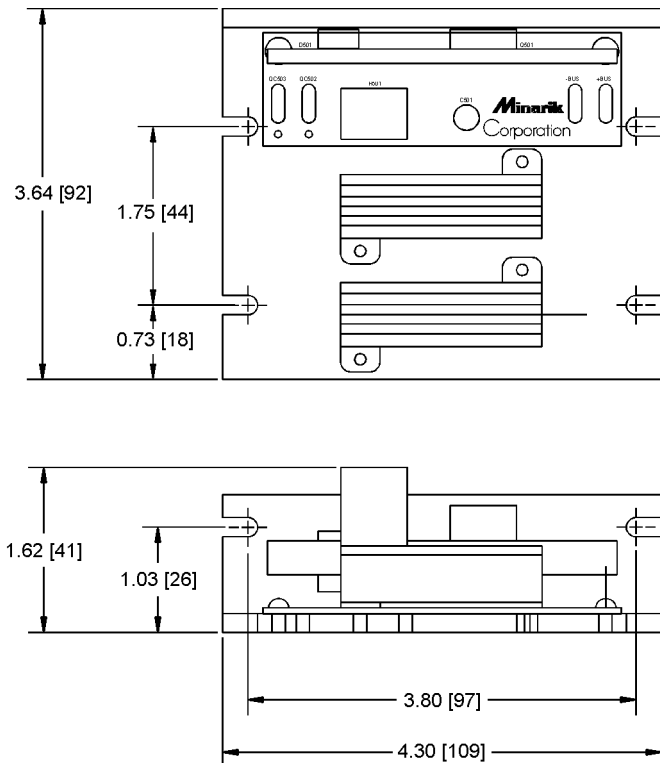

Figure 2. BOSS DB Regen Dump Circuit Dimensions

Installation

Drive mounting



Warning

Do not install, rewire, or remove this control with input power applied. Doing so may cause fire or serious injury. Make sure you have read and understood the Safety Warnings before attempting installation.

- Drive components are sensitive to electrostatic fields. Avoid contact with the circuit board directly. Hold the drive by the chassis only.
- Protect the drive from dirt, moisture, and accidental contact. Provide sufficient room for access to the terminal block and calibration trimpots.
- Mount the drive away from other heat sources. Operate the drive within the specified ambient operating temperature range.
- Prevent loose connections by avoiding excessive vibration of the drive.
- Mount drive with its board in either a horizontal or vertical plane. Six 0.19 in. (5 mm) wide slots in the chassis accept #8 pan head screws. Fasten either the large base or the narrow flange of the chassis to the subplate.
- The chassis does not have to be earth grounded. If you choose to ground the chassis, use a star washer beneath the head of at least one of the mounting screws to penetrate the anodized chassis surface and to reach bare metal.

Wiring



Warning



Do not install, remove, or rewire this equipment with power applied. Failure to heed this warning may result in fire, explosion, or serious injury.

Circuit potentials are at 115 VAC above ground. To prevent the risk of injury or fatality, avoid direct contact with the printed circuit board or with circuit elements.

Do not disconnect any of the motor leads from the drive unless power is removed. Opening any one motor lead may destroy the drive.

- Use 16 AWG wire for the AC or DC voltage input wiring (AC1 and AC2 or +VDC and -VDC), regen dump circuit, and motor wiring (U, V, W). Use 18-20 AWG wire for speed adjust potentiometer wiring.

Shielding guidelines



Warning

Under no circumstances should power and logic leads be bundled together. Induced voltage can cause unpredictable behavior in any electronic device, including motor controls.

Minarik recommends shielding all leads. If shielding is not practical, the user should twist all logic leads with themselves to minimize induced noise.

It may be necessary to earth ground the shielded cable. If noise is produced by devices other than the drive, ground the shield at the drive end. If noise is generated by a device on the drive, ground the shield at the end away from the drive. Do not ground both ends of the shield.

If the drive continues to pick up noise after grounding the shield, it may be necessary to add AC line filtering devices, or to mount the drive in a less noisy environment.

Fusing

An external line fuse must be installed on all BOSS series drives. Connect the external line fuse in series with the AC voltage input terminal AC1 or DC voltage input terminal +VDC, whichever is used. See motherboard connections (Figure 6) on page 14.

Table 1 lists the recommended line fuse sizes. Use fast acting fuses rated for 250 VAC or higher.

Table 1. Recommended Line Fuse Sizes

Model Series	Line Fuse Size (AC Amps)
BOSS04	10
BOSS08	15
BOSS15	25

Plug-in card mounting



Warning

Make sure AC or DC line voltage input is disconnected for 30 seconds before installing or removing the plug-in card.

To mount the plug-in card to the motherboard, line up the motherboard docking pins to the docking holes (Figure 3). Align the header pins on the plug-in card with the corresponding header sockets on the motherboard. Fasten the header pins into the header sockets until secure. The docking pins will lock the plug-in card into place when the header pins are correctly mounted into the header sockets.

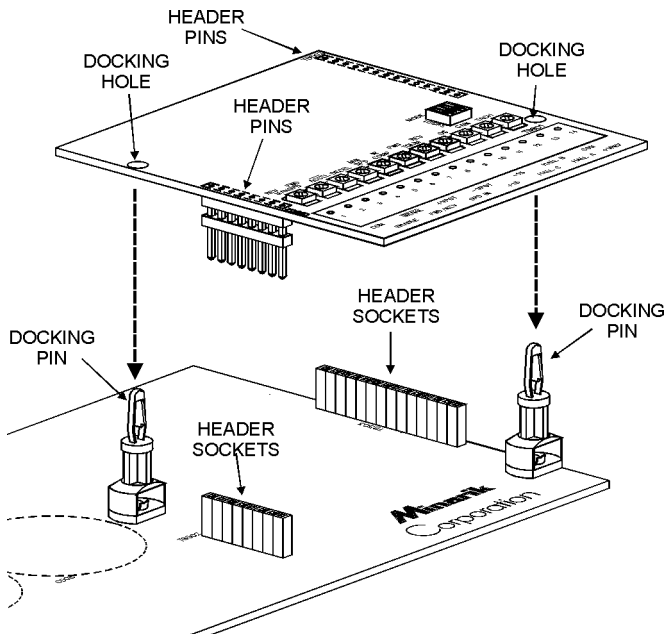

(Make sure AC or DC voltage input is removed for 30 seconds before installing or removing plug-in card)

Figure 3. Plug-In Card Installation

Speed adjust potentiometer mounting



Warning

Be sure that the potentiometer tabs do not make contact with the potentiometer enclosure. Grounding the input will cause damage to the drive.

Mount the speed adjust potentiometer through a 0.38-inch (1.0 cm) hole with the hardware provided (Figure 4). Install the circular insulating disk between the panel and the 10K ohm speed adjust potentiometer. Twist the speed adjust potentiometer wire to avoid picking up unwanted electrical noise. If potentiometer leads are longer than 18 inches (46 cm), use shielded cable.

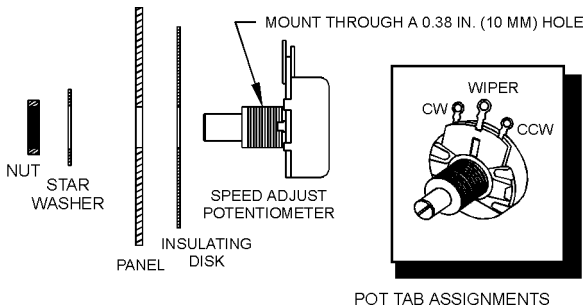

Figure 4. Speed Adjust Potentiometer Mounting

Quick-connect terminal block

The quick-connect terminal block is composed of a header block and terminal plug. The removable terminal plug, Minarik part number 160-0126, connects to the header block as shown in Figure 5. To use the quick-connect terminal block:

1. Carefully pull terminal plug from header block.
2. With a small flat-head screwdriver, turn terminal plug screw counterclockwise to open wire clamp.
3. Insert stripped wire into the large opening in front of the plug.
4. Turn the terminal plug screw clockwise to clamp the wire.
5. Repeat steps 2–4 for each terminal until all connections are made.
6. Insert plug into header block until securely fastened.

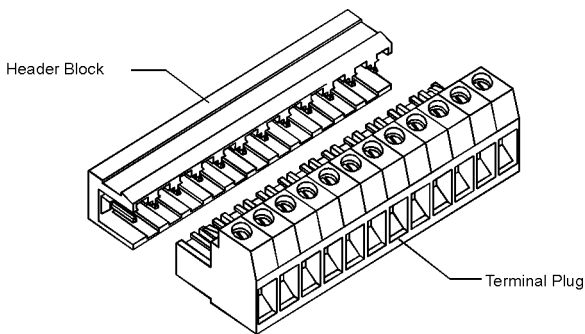

Figure 5. Quick-Connect Terminal Plug

Motherboard connections



Warning

Do not install, remove, or connect this equipment with power applied. Failure to heed this directive may result in fire or serious injury.

Minarik strongly recommends the installation of a master power switch in the voltage input line. The switch contacts should be rated at a minimum of 200% of motor nameplate current and 150% of input voltage.

Do not connect DC and AC power inputs at the same time. Applying AC and DC power simultaneously will destroy the drive and may result in fire or serious injury.

Power connections

See Figure 6 (page 14) for motherboard connections. Connect the AC voltage source to AC1 and AC2 if using an AC voltage source. If the drive is being powered by a DC voltage source, connect the DC voltage source to +VDC and -VDC. **Do not connect AC and DC voltage sources at the same time!**

Line fusing

Connect an external fuse between the drive and master stop switch as shown in Figure 6 (page 14). Install the switch between the external fuse and AC or DC power input as shown. Place a line fuse on +VDC if using DC input voltage, or AC1 if using AC line voltage. Refer to Table 1 (page 7) for replacement line fuse sizes.

Power switch



Warning

Minarik strongly recommends the installation of a master power switch in the voltage input line. The switch contacts should be rated at a minimum of 200% of motor nameplate current and 250 volts.

Install a master power switch in the voltage input line, as shown in Figure 6 (page 14). The switch contacts should be rated at a minimum of 200% of motor nameplate current and 250 volts.

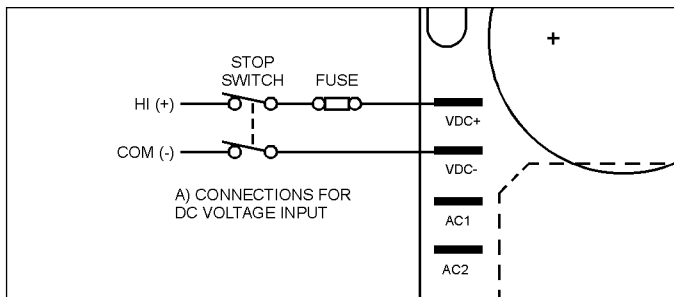

OR

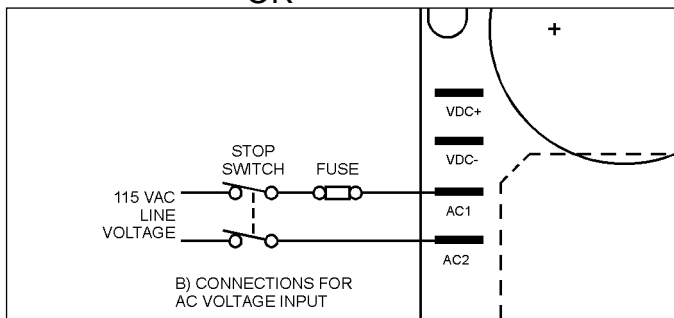

Warning

Do not connect AC and DC voltage at the same time.
This will destroy the BOSS drive and may result in fire or serious personal injury.

Figure 6. Motherboard Connections for (a) DC input voltage and (b) AC input voltage

Motor connections

Connect a three-phase motor to the motherboard as shown in Figure 7. Ensure that the motor's voltage and current ratings are compatible with the drive ratings before making any connections.

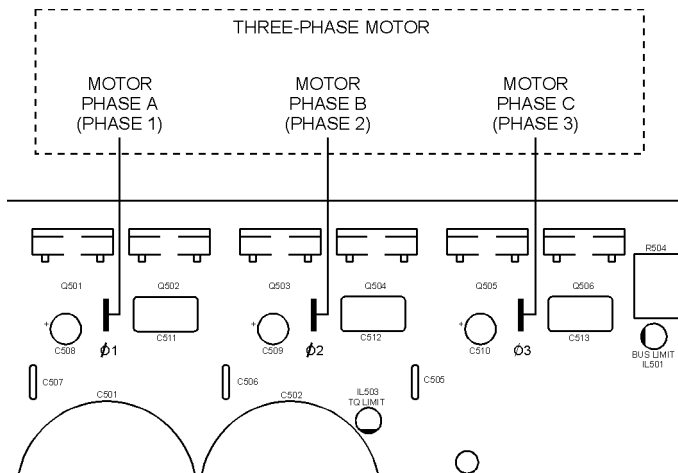

Figure 7. Motherboard Connections for Three-Phase Motor

Regen dump circuit

The regen dump circuit is recommended for all BOSS Series drives. Regenerative loads may cause the bus voltage to increase. The regen dump circuit prevents the voltage across the bus capacitors from exceeding their voltage rating.

Connect the +BUS terminal on the regen dump circuit to the +VDC terminal on the BOSS drive motherboard. Connect the -BUS terminal on the regen dump circuit to the -VDC terminal on the BOSS drive motherboard. See Figure 8 for regen dump circuit connections.

Frequent regenerative reversing requires additional power resistors to be added to the regen dump circuit. Contact the Minarik factory for more assistance.

Using the dump circuit with a DC power source

If you use a DC power source and you wish to use the regen dump circuit, you must connect the power source to the BOSS drive AC1 and AC2 terminals as shown in Figure 8. Connect the positive (+) lead from the DC power source to the AC1 terminal on the BOSS drive motherboard. Connect the negative (or COM) lead from the DC power source to the AC2 terminal on the BOSS drive motherboard.

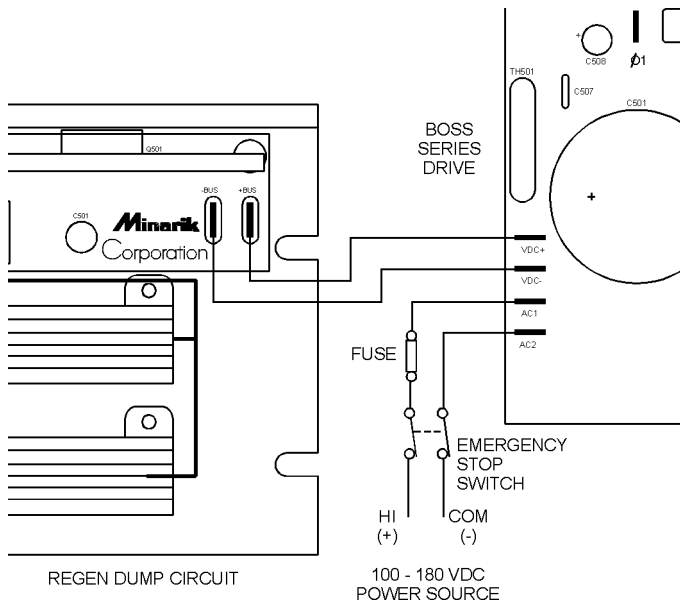

Figure 8. Regen Dump Circuit Connections

BOSS-1Q terminal descriptions

NOTE: Make no connection to terminal 7 of the removable terminal plug. Refer to Figure 9 (page 21) for a connection diagram. Refer to Figure 10 (page 23) for information on connecting hall sensors.

COM (terminals 1 and 12)



Warning

Do not connect these terminals to earth ground.

Circuit common.

ENABLE/DISABLE (terminal 2)

Short to COM to coast the motor to a stop; leave open to run the motor.

RUN/BRAKE (terminal 3)

Short to COM to run the motor. Open the connection to brake. When braking, high-side power devices turn off, low-side power devices turn on and the motor brakes to a stop. An external braking resistor is not required because current is dissipated through the motor windings.

FWD/REV (terminal 4)

Short to COM for reverse direction; leave open for forward direction. Hall sensors A and C (or 1 and 3) are exchanged, reversing commutation sequence.

+V POT (terminal 5)

Floating +10 VDC reference for 10K ohm speed adjust potentiometer.

SPEED IN (terminal 6)

Accepts floating (ungrounded) 0 to +10 VDC reference or 10K ohm speed adjust potentiometer wiper.

-V POT (terminal 7)

Floating -10 VDC reference; used on future drives. Make no connections to this terminal.

HALL C, B, A (terminals 8, 9 and 10)

Inputs for motor hall sensors.

+ 5 VDC Vref (terminal 11)**Warning**

The +5 VDC supply has a maximum capacity of 20 mADC. Please ensure that any sensor package connected to this terminal does not draw more than 20 mADC. If the sensor package draws more than 20 mADC, it must be connected to an external, regulated power supply as shown in Figure 10 (page 23).

Floating (isolated) +5 VDC, 20 mA supply for external sensors.

BOSS-1Q terminal connections



Warning

Do not install, rewire, or remove this control with input power applied. Doing so may cause fire or serious injury. Make sure you have read and understood the Safety Warnings before attempting installation.

ENABLE/DISABLE switch

Connect a single-pole, single-throw switch between the COM and ENABLE terminals (terminals 1 and 2) of TB501 as shown in Figure 9. Close the switch to coast the motor to a stop. Open the switch to accelerate to set speed.

RUN/BRAKE switch

Connect a single-pole, single-throw switch between the COM and RUN/BRAKE terminals (terminals 1 and 3) of TB501 as shown in Figure 9. Open the switch to brake the motor to a stop. Close the switch to accelerate to set speed.

FWD/REV switch

Connect a single-pole, single-throw switch between the COM and FWD/REV terminals (terminals 1 and 4) of TB501 as shown in Figure 9. Open the switch to run the motor in the forward direction. Close the switch to run the motor in the reverse direction.

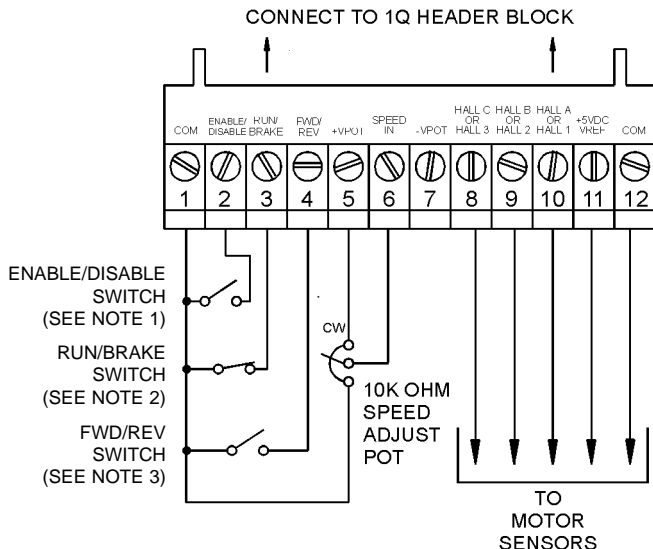
**NOTES:**

1. CLOSE THE ENABLE/DISABLE SWITCH TO COAST THE MOTOR TO A STOP; LEAVE OPEN TO RUN.
2. OPEN THE RUN/BRAKE SWITCH TO BRAKE THE MOTOR TO A STOP; CLOSE THE SWITCH TO RUN.
3. OPEN THE FWD/REV SWITCH TO RUN THE MOTOR IN THE FORWARD DIRECTION; CLOSE THE SWITCH TO REVERSE.
4. MAKE NO CONNECTION TO TERMINAL 7.

Figure 9. BOSS-1Q Terminal Connections

Motor hall sensors



Warning

BOSS series drives provide a +5 VDC supply to drive external sensors. This voltage has a maximum capacity of 20 mADC. To avoid damage to the drive, ensure that any sensor package powered by the BOSS drive does not draw more than 20 mADC.

BOSS series drives work with three-phase, 130 VAC brushless motors with nulled hall sensors (60° or 120° electrical spacing). Hall sensors are not allowed to be advanced or retarded. To reverse motor rotation, the BOSS drive switches hall sensor sequence, eliminating the need to switch motor leads. BOSS-1Q drives are factory set for 120° spacing. Contact the factory if you require 60° spacing.

To run with sensor (hall-track) feedback, refer to Figure 10. This voltage is provided at TB501 terminal 11 (positive) and terminal 12 (common or ground). If the sensor draws more than 20 mADC, it must be connected to an external, regulated power supply which provides a floating output.

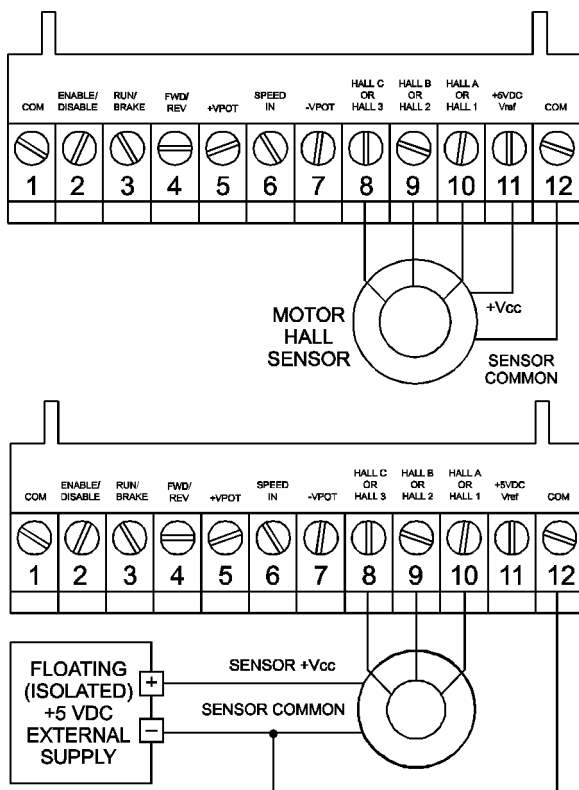

Figure 10. BOSS-1Q Sensor Connections

Operation



Warning

Dangerous voltages exist on the drive when it is powered, and up to 30 seconds after power is removed and the motor stops. BE ALERT. High voltages can cause serious or fatal injury.

Before applying power

- Verify that no conductive material is present on the printed circuit board (PCB).

Startup

1. Verify that no conductive material is present on the PCB.
2. Check that the ENABLE/DISABLE switch is in the enable position (open). If no switch is installed, remove the jumper between the ENABLE and COM terminals on TB501.
3. Check that the RUN/BRAKE switch is in the run position (closed). If no switch is installed, install a jumper between the RUN/BRK and COM terminals on TB501.
4. Set the FWD/REV switch to the direction you want the motor to rotate upon startup.
5. Apply AC or DC voltage input to the drive.
6. Slowly advance the speed adjust potentiometer clockwise (CW). If a voltage signal is used, slowly increase the voltage signal. The motor slowly accelerates as the potentiometer is turned CW, or the voltage signal is increased. Continue until the desired speed is reached.

To reverse motor direction:

Switch the FWD/REV switch to the opposite position. (To prevent possible demagnetization of the motor, consider braking the motor to a stop before reversing polarity. Once stopped, release the brake input.)

Starting and stopping methods



Warning

Decelerating to minimum speed, regenerative braking, or coasting to a stop is recommended for frequent starts and stops. Do not use any of these methods for emergency stopping. They may not stop a drive that is malfunctioning. Removing line voltage (AC1 and AC2 or +VDC and -VDC) is the only acceptable method for emergency stopping.

For this reason, **Minarik strongly recommends installing an emergency stop switch on both of the power input leads** (see *Motherboard Connections* on page 12).

To brake the motor

Open the RUN/BRAKE switch.

To coast the motor to a stop without disconnecting power

Close the ENABLE/DISABLE switch.

Line starting and line stopping

Line starting and line stopping (applying and removing AC or DC voltage input) is not recommended for frequent starting and stopping of the drive. It is the only recommended method for emergency stopping of the drive. When AC or DC voltage input is applied to the drive, the motor accelerates to the speed set by the speed adjust potentiometer or analog voltage signal. When AC or DC voltage input is removed, the motor coasts to a stop.

Calibration



Warning

Dangerous voltages exist on the drive when it is powered, and up to 30 seconds after power is removed and the motor stops. When possible, disconnect the voltage input from the drive before adjusting the trimpots. If the trimpots must be adjusted with power applied, use insulated tools and the appropriate personal protection equipment. BE ALERT. High voltages can cause serious or fatal injury.

Each drive is factory calibrated to its maximum current rating. Readjust the calibration trimpot settings to accommodate lower current motors.

All adjustments increase with CW rotation, and decrease with CCW rotation. Use a non-metallic screwdriver for calibration. Each trimpot is identified on the printed circuit board.

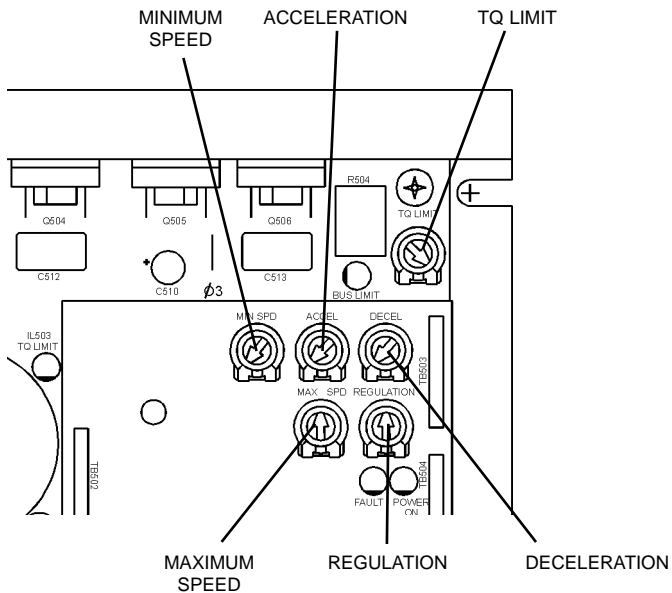

Figure 12. BOSS-1Q Calibration Trimpot Layout

Calibration procedure

Calibrate the BOSS-1Q using the following procedure:

1. Ensure that no power is applied to the drive.
2. Set the ENABLE/DISABLE switch to the ENABLE position (open), or remove the short between the ENABLE and COM terminals on TB501.
3. Set the RUN/BRAKE switch to the RUN position (closed), or add a jumper between the RUN/BRAKE and COM terminals on TB501.
4. Set the FWD/REV switch to the desired direction.
5. Set the MAX SPD and REGULATION trimpots to the center of travel (12 o'clock position).
6. Set the MIN SPD, ACCEL and DECEL trimpots full counterclockwise (CCW).
7. Set the TQ LIMIT trimpot full clockwise (CW).
8. Set the signal input (analog voltage signal or speed adjust potentiometer) to zero.
9. Apply power to the drive.
10. Calibrate the trimpots as follows:

MINIMUM SPEED (MIN SPD)

The MIN SPD setting determines the motor speed when the speed adjust potentiometer is turned full CCW. It is factory set to zero speed.

To calibrate, set the reference potentiometer or reference signal to zero. To set the minimum speed to zero, rotate the MIN SPD trimpot CCW until the motor has stopped. To set a minimum speed higher than zero, rotate the MIN SPD trimpot CW until the motor is running at the desired minimum speed.

MAXIMUM SPEED (MAX SPD)

The MAX SPD setting determines the motor speed when the speed adjust potentiometer is turned full CW. It is factory set for maximum rated speed.

To calibrate, set the MAX SPD trimpot full CCW. Set the reference potentiometer or reference signal to maximum. Adjust the MAX SPD trimpot until the desired maximum motor speed is reached.

NOTE: Check the MIN SPD and MAX SPD adjustments after recalibrating to verify that the motor runs at the desired minimum and maximum speed.

ACCELERATION (ACCEL)

The ACCEL setting determines the time the motor takes to ramp to a higher speed. See *Specifications* (page 1) for approximate acceleration times. The ACCEL setting is factory set to its minimum value (full CCW).

1. Set the speed adjust potentiometer or input signal to zero speed.
2. Set the speed adjust potentiometer or input signal to maximum speed.
3. Measure the time the motor takes to reach the set speed.
4. Turn the ACCEL trimpot CW to increase the acceleration time, and CCW to decrease the acceleration time, until the desired acceleration time is reached.

DECELERATION (DECEL)

The DECEL setting determines the time the motor takes to ramp to a lower speed. See *Specifications* (page 1) for approximate deceleration times. The DECEL setting is factory set to its minimum value (full CCW).

1. Set the speed adjust potentiometer or input signal to maximum speed.
2. Set the speed adjust potentiometer or input signal to zero speed.
3. Measure the time the motor takes to reach zero speed.
4. Turn the DECEL trimpot CW to increase the deceleration time, and CCW to decrease the deceleration time, until the desired deceleration time is reached.

REGULATION

The REGULATION setting determines the degree to which motor speed is held constant as the motor load changes. It is factory set for optimum motor gain.

Recalibrate the REGULATION setting when using a lower horsepower motor. Use the following procedure:

If the motor does not maintain set speed as the load increases, gradually rotate the REGULATION trimpot CW. If the motor oscillates (overcompensation), the REGULATION trimpot may be set too high (CW). Turn the REGULATION trimpot CCW to stabilize the motor.

TORQUE LIMIT (TQ LIMIT)



Warning

Although TQ LIMIT is set to 120% of the drive's maximum current rating, continuous operation beyond that rating may damage the motor or drive. If you intend to operate beyond the rating, contact your Minarik representative for assistance.

The TQ LIMIT setting determines the maximum motor current output of the drive. It is factory set at 120% of the drive's maximum current rating. TQ LIMIT should be recalibrated when using a motor with a lower current rating.

1. With no power applied to the drive, connect a DC ammeter in series with the motor armature.
2. Set the TQ LIMIT trimpot to full CCW.
3. Carefully lock the motor armature. Ensure that the motor is firmly mounted.
4. Apply line power. The motor should be stopped.
5. Set the speed potentiometer or reference signal to maximum speed. The motor should remain stopped.
6. Slowly rotate the TQ LIMIT trimpot clockwise (CW) until the ammeter reads 120% of maximum motor current.
7. Set the speed adjust potentiometer or reference signal to zero speed.
8. Remove power from the drive.
9. Remove the lock from the motor shaft.
10. Remove the ammeter in series with the motor armature.

Troubleshooting



Warning

Dangerous voltages exist on the drive when it is powered, and up to 30 seconds after power is removed and the motor stops. **BE ALERT.** High voltages can cause serious or fatal injury.

Before troubleshooting

- Disconnect AC or DC voltage input from the drive. Wait 30 seconds for power to discharge.
- Check the drive closely for damaged components.
- Check that no wire, chips or other foreign material has become lodged on the printed circuit board.
- Verify that every connection is correct and in good condition.
- Verify that there are no short circuits or grounded connections.
- Check that the drive's rated phase current and RMS voltage are consistent with the motor ratings.

For additional assistance, contact your local Minarik® distributor, or the factory direct: 1-800-MINARIK (646-2745) or Fax: 1-800-394-6334.

BOSS-1Q Diagnostic LEDs

Diagnostic LEDs on the BOSS-1Q plug-in card:

POWER ON

The POWER ON LED lights when power is applied to the drive and the plug-in card is connected properly.

FAULT

The FAULT LED lights in any of the following conditions:

1. The hall sensors are miswired, not operating properly, not properly nulled, or draw current in excess of 20 mA.
2. The drive reaches its peak phase current limit.
3. The drive has insufficient AC or DC power.
4. The enable switch is closed (drive is disabled).

Diagnostic LEDs on the motherboard:

BUS LIMIT

The red BUS LIMIT LED lights when the drive exceeds maximum bus voltage. This applies when the drive is in the regenerative mode (future drives).

TQ LIMIT

The red TQ LIMIT LED lights when the drive output current reaches the maximum phase current limit.

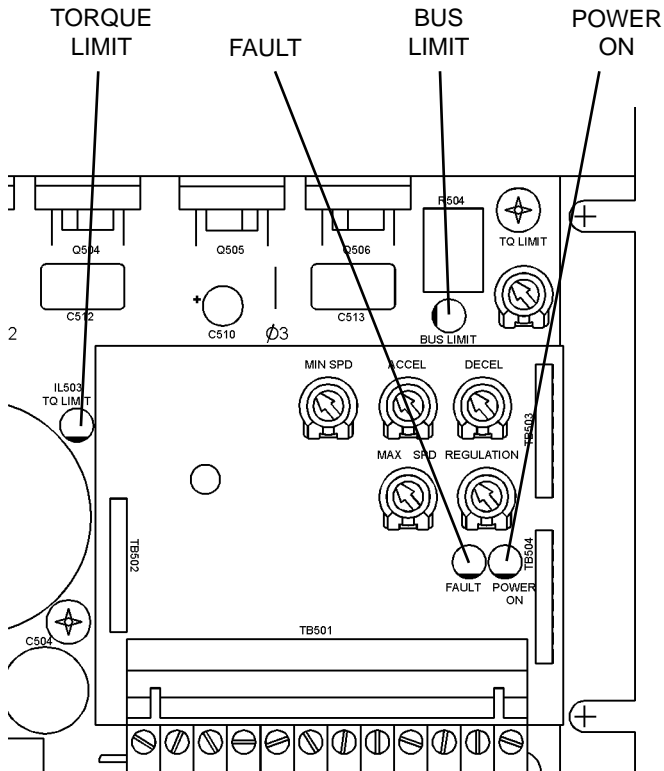

Figure 13. BOSS-1Q Diagnostic LED Location

Symptom	Possible Causes	Suggested Solutions
External line fuse blows	<ol style="list-style-type: none">1. Line fuses are the wrong size.2. Motor cable or motor is shorted to ground.3. Nuisance tripping caused by a combination of ambient conditions and high-current spikes (i.e. reversing).	<ol style="list-style-type: none">1. Check that line fuses are properly sized for the motor being used.2. Check motor cable and motor for shorts.3. Add a blower to cool the drive components; increase TQ LIMIT setting.
External line fuse does not blow, but the motor does not run	<ol style="list-style-type: none">1. Speed adjust potentiometer or voltage input signal is set to zero speed.2. Speed adjust potentiometer or voltage input signal is not connected to drive input properly; connections are open.3. Drive is disabled; BRAKE terminal is open to COM.	<ol style="list-style-type: none">1. Increase the speed adjust potentiometer setting or voltage input signal.2. Check connections to input. Verify that connections are not open.3. Check connections.

Symptom	Possible Causes	Suggested Solutions
External line fuse does not blow, but the motor does not run (cont.)	<p>4. Drive is in torque limit.</p> <p>5. Drive is not receiving AC voltage input or DC voltage input.</p> <p>6. Motor is not connected.</p> <p>7. Hall sensors not connected.</p> <p>8. Sensor draws too much current for BOSS drive to supply.</p>	<p>4. Verify that motor is not jammed. Increase TQ LIMIT setting if it is set too low.</p> <p>5. Apply AC line voltage to AC1 and AC2, or DC voltage input to +VDC or -VDC.</p> <p>6. Check motor connections.</p> <p>7. Connect hall sensors.</p> <p>8. Check sensor wiring. If sensor needs more than 20 mADC, connect sensor to external power supply.</p>

Symptom	Possible Causes	Suggested Solutions
Motor runs too slow or too fast at set speed	<ol style="list-style-type: none">1. MIN SPD or MAX SPEED not calibrated properly.2. Hall sensors miswired.	<ol style="list-style-type: none">1. Calibrate MIN SPD and MAX SPD.2. Check hall sensor connections.
Motor will not reach the desired speed	<ol style="list-style-type: none">1. MAX SPD setting is too low.2. REGULATION setting is too low.3. Motor is overloaded.4. Hall sensors miswired.	<ol style="list-style-type: none">1. Increase MAX SPD setting.2. Recalibrate REGULATION setting.3. Check motor load. Resize the motor and drive if necessary.4. Check hall sensor connections.

Symptom	Possible Causes	Suggested Solutions
Motor pulsates or surges under load	<ol style="list-style-type: none">1. REGULATION is set too high.2. Motor “bouncing” in and out of torque limit.	<ol style="list-style-type: none">1. Adjust the REGULATION setting until the motor speed stabilizes.2. Make sure motor is not undersized for load; adjust TQ LIMIT setting.
Motor does not reverse	<ol style="list-style-type: none">1. Bad FWD/REV switch connection.2. Reversing circuit not working properly.3. Hall sensors miswired.	<ol style="list-style-type: none">1. Check FWD/REV switch connection.2. Check reversing circuit by shorting FWD/REV terminal to COM terminal with jumper wire.3. Check hall sensor connections.

Symptom	Possible Causes	Suggested Solutions
FAULT LED lit.	<ol style="list-style-type: none"><li data-bbox="368 207 632 332">1. The hall sensors are miswired, not operating properly, or not properly nulled.<li data-bbox="368 369 627 457">2. The drive reaches its peak phase current limit.<li data-bbox="368 560 615 648">3. The drive has insufficient AC or DC power.<li data-bbox="368 685 622 773">4. The enable switch is closed (drive is disabled)<li data-bbox="368 810 615 898">5. The drive reaches maximum bus voltage limit.<li data-bbox="368 1001 629 1089">6. Sensor draws too much current for BOSS drive to supply.	<ol style="list-style-type: none"><li data-bbox="674 207 905 267">1. Check hall sensor wiring.<li data-bbox="674 369 926 523">2. Check that motor is properly sized for load; check that TQ LIMIT trimpot is properly calibrated.<li data-bbox="674 560 923 589">3. Check input power.<li data-bbox="674 685 919 780">4. Check that enable switch is in the proper operating position.<li data-bbox="674 810 923 964">5. Check motor load; check that motor is properly sized for load and is not stuck or jammed.<li data-bbox="674 1001 888 1188">6. Check sensor wiring. If sensor needs more than 20 mADC, connect sensor to external power supply.

Notes

Notes

Notes

Unconditional Warranty

A. Warranty

Minarik Corporation (referred to as "the Corporation") warrants that its products will be free from defects in workmanship and material for twelve (12) months or 3,000 hours, whichever comes first, from date of manufacture thereof. Within this warranty period, the Corporation will repair or replace, at its sole discretion, such products that are returned to Minarik Corporation, 901 East Thompson Avenue, Glendale, CA 91201-2011 USA.

This warranty applies only to standard catalog products, and does not apply to specials. Any returns for special controls will be evaluated on a case-by-case basis. The Corporation is not responsible for removal, installation, or any other incidental expenses incurred in shipping the product to and from the repair point.

B. Disclaimer

The provisions of Paragraph A are the Corporation's sole obligation and exclude all other warranties of merchantability for use, express or implied. The Corporation further disclaims any responsibility whatsoever to the customer or to any other person for injury to the person or damage or loss of property of value caused by any product that has been subject to misuse, negligence, or accident, or misapplied or modified by unauthorized persons or improperly installed.

C. Limitations of Liability

In the event of any claim for breach of any of the Corporation's obligations, whether express or implied, and particularly of any other claim or breach of warranty contained in Paragraph A, or of any other warranties, express or implied, or claim of liability that might, despite Paragraph B, be decided against the Corporation by lawful authority, the Corporation shall under no circumstances be liable for any consequential damages, losses, or expense arising in connection with the use of, or inability to use, the Corporation's product for any purpose whatsoever.

An adjustment made under warranty does not void the warranty, nor does it imply an extension of the original 12-month warranty period. Products serviced and/or parts replaced on a no-charge basis during the warranty period carry the unexpired portion of the original warranty only.

If for any reason any of the foregoing provisions shall be ineffective, the Corporation's liability for damages arising out of its manufacture or sale of equipment, or use thereof, whether such liability is based on warranty, contract, negligence, strict liability in tort, or otherwise, shall not in any event exceed the full purchase price of such equipment.

Any action against the Corporation based upon any liability or obligation arising hereunder or under any law applicable to the sale of equipment or the use thereof, must be commenced within one year after the cause of such action arises.

Also available from Minarik Corporation:

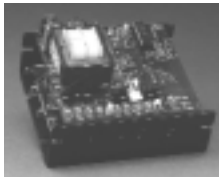

**MMRGD Series
Digital SCR Regen**



**DLC600
Digi-Lok® Controller**



**NRGD Series
Digital Brush Servo**

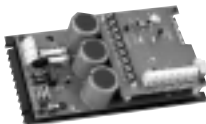

**NRG-4Q Series
Brush Servo**



901 East Thompson Avenue
Glendale, California 91201-2011
Tel.: 1-800-MINARIK (646-2745)
Fax: 1-800-394-6334

www.minarikcorp.com

Document number 250-0224, Revision 2

Printed in the U.S.A – 5/01

\$11.00 North America – \$12.00 Outside North America