

Chapter 20 FBs-4A2D Analog Input/Output Module

FBs-4A2D is one of the analog I/O modules of FATEK FBs series PLC. For analog output it provides 2 channels of 14 bit D/A output. Base on the different jumper settings it can provide varieties of current or voltage output signal. The output code can be configured as unipolar or bipolar which makes the relation of output code and real output signal more intuitive. For safety, the output signal will be automatically forced to zero(0V or 0mA) when the module is not serviced by CPU for 0.5 second.

For analog input it provides 4 channels A/D input with 12 or 14 bits effective resolution. Base on the different jumper settings it can measure the varieties of current or voltage signal. The reading value is represented by a 14 bit value no matter the effective resolution is set to 12 or 14 bits The output code also can be configured as unipolar or bipolar which makes the relation of input code and real input signal more intuitive.. In order to filter out the field noise imposed on the signal, it also provides the average of sample input function.

20.1 Specifications of FBs-4A2D

General specifications

Isolation	Transformer(Power) and photocouple(Signal)	
Indicator(s)	5V PWR LED	
Internal Power Consumption	5V · 100mA	
External power supply	24V-15%/+20% · 100mA	
Operating Temperature	0 ~ 60 °C	
Storage Temperature	-20 ~ 80 °C	
Dimensions	40(W)x90(H)x80(D) mm	

Analog output specifications

Item		Specifications		Remark
Output Channel		2 Channel (2DA)		
Digital Output Value		-8192 ~ +8191(Bipolar) or 0 ~ 16383(Unipolar)		
Span Of Analog output	Bipolar*	*10V	*1. Voltage : -10 ~ 10V 5. Current : -20 ~ 20mA	* : It means the default setting
		5V	2. Voltage : -5 ~ 5V 6. Current : -10 ~ 10mA	
	Unipolar	10V	3. Voltage : 0 ~ 10V 7. Current : 0 ~ 20mA	
		5V	4. Voltage : 0 ~ 5V 8. Current : 0 ~ 10mA	
Resolution		14 bits		
Finest resolution		0.3mV(Voltage) · 0.61µA(Current)		
I/O Points Occupied		2 OR(Output register)		
Accuracy		Within ±1% of full scale		
Conversion Time		Updated each scan		
Maximum accommodation for resistance loading		Voltage : 500Ω ~ 1MΩ Current : 0Ω ~ 300Ω		The deviation will be enlarged if exceeding this range

Analog input specifications

Item		Specifications		Remark
Input Channel		4 Channel (4AD)		
Digital Input Value		-8192~+8191or 0~16383(14bit) -2048~+2047or 0~4095(12bit)		
Span Of Analog Input	Bipolar*	*10V	*1. Voltage : -10~10V 5. Current : -20~20mA	* : It means the default setting
		5V	2. Voltage : -5~5V 6. Current : -10~10mA	
	Unipolar	10V	3. Voltage : 0~10V 7. Current : 0~20mA	
		5V	4. Voltage : 0~5V 8. Current : 0~10mA	
Resolution		14 or 12 bit		
Finest resolution		Voltage : 0.3mV Current : 0.61μA		=Analog Input Signal/ 16383(rounded the third decimal place)
I/O Points Occupied		4 IR(Input register)		
Accuracy		Within ±1% of full scale		
Conversion Time		Updated each scan		
Maximum absolute input signal		Voltage : ±15V (max) Current : ±30mA (max)		It may cause the destruction to hardware if exceeds this value.
Input resistance		63.2KΩ (Voltage input) · 250Ω (Current Input)		

20.2 The procedure of using FBs-4A2D analog input/output module

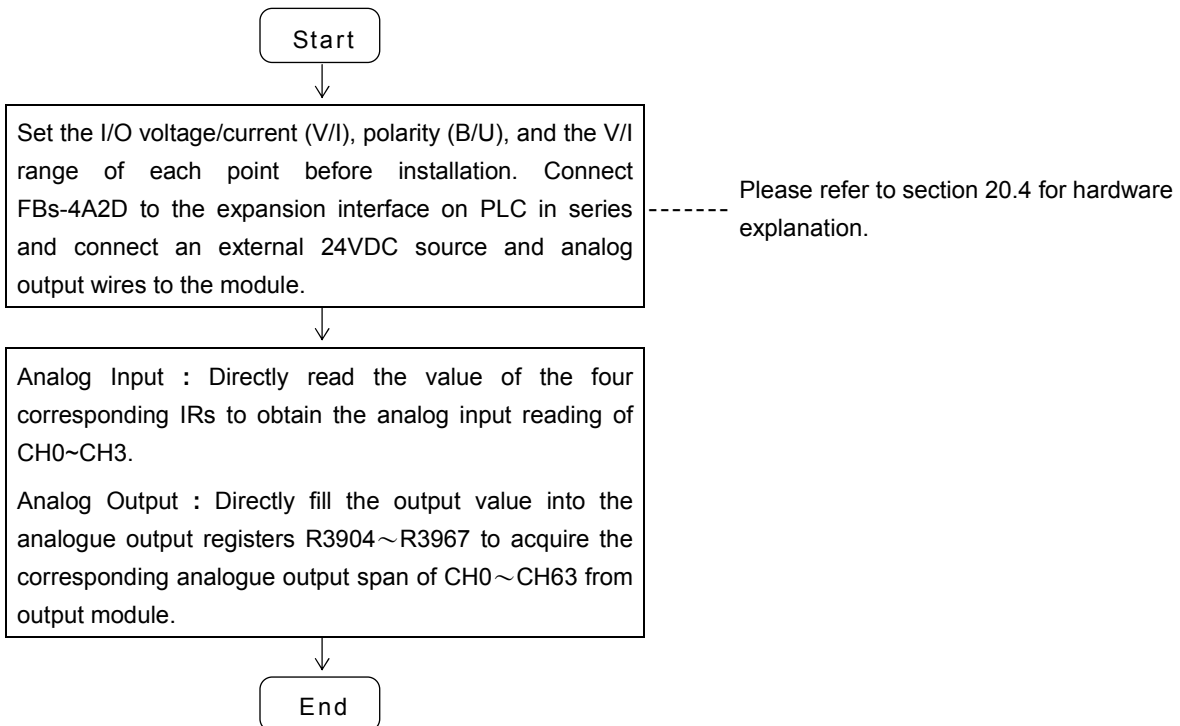

20.3 Address allocation of FBs-PLC analog inputs/outputs

FBs-4A2D offers 4 AD points and 2 DA points. The AD points number starts from the one nearest to the PLC, the number in order is CH0~CH3 (module 1); CH4~CH7 (module 2); CH8~CH11 (module 3); etc, accumulates in serial; i.e. add 4 to each module, the total is 64 points (CH0~CH63) corresponding top the value IRs inside the PLC (R3840~R3903), respectively. In DA point numbering, from the one nearest to the PLC, the number runs from CH0 through to CH63 in serial, the total is 64 points corresponding top the value ORs inside the PLC (R3904~R3967), respectively. After connecting FBs-4A2D to the expansion interface on the PLC, FBs-PLC will automatically detect the number of AD/DA points. WinProladder will automatically detect and calculate the value IRs/ORs on the system after connecting to the PLC. Users may refer to the I/O Module Number Configuration provided by WinProladder in order to find out the exact I/O address of each expansion module to facilitate programming (see I/O Number Configuration, Section 12.6, WinProladder User's Manual for details).

Address allocation of FBs-4A2D(Analog output)

Numeric Output Register (OR)	Content of OR (CH0~CH63)																Output lable	
	B15	B14	B13	B12	B11	B10	B9	B8	B7	B6	B5	B4	B3	B2	B1	B0		
OR+0	*	*	CH0 output value													B0	CH0	} FBs-4A2D
OR+1	*	*	CH1 output value														CH1	
OR+2	Depends on module type																CHX	} Other modules
OR+3	Depends on module type																CHX	
⋮	⋮	⋮	⋮	⋮	⋮	⋮	⋮	⋮	⋮	⋮	⋮	⋮	⋮	⋮	⋮	⋮	⋮	⋮
R3966	Depends on module type																CHX	
R3967	Depends on module type																CHX	

* * ----- Unipolar code output (0~16383) · B14 · B15 = 00
 Bipolar code output (-8192~8191) · B14 · B15 = B13

Address allocation of FBs-4A2D(Analog input)

Numeric Input Register (IR)	Content of IR (CH0~CH63)																Input lable	
	B15	B14	B13	B12	B11	B10	B9	B8	B7	B6	B5	B4	B3	B2	B1	B0		
IR+0	14/12 bit ; 14-bit , B14~ B15= B13 ; 12-bit, B12~ B15= B11																CH0	} FBs-4A2D
IR+1	14/12 bit ; 14-bit , B14~ B15= B13 ; 12-bit, B12~ B15= B11																CH1	
IR+2	"																CH2	
IR+3	"																CH3	

⋮	⋮	⋮	} Other modules
R3900	Depends on module type	CHX	
R3901	Depends on module type	CHX	
R3902	//	CHX	
R3903	//	CHX	

20.4 FBs-4A2D hardware description

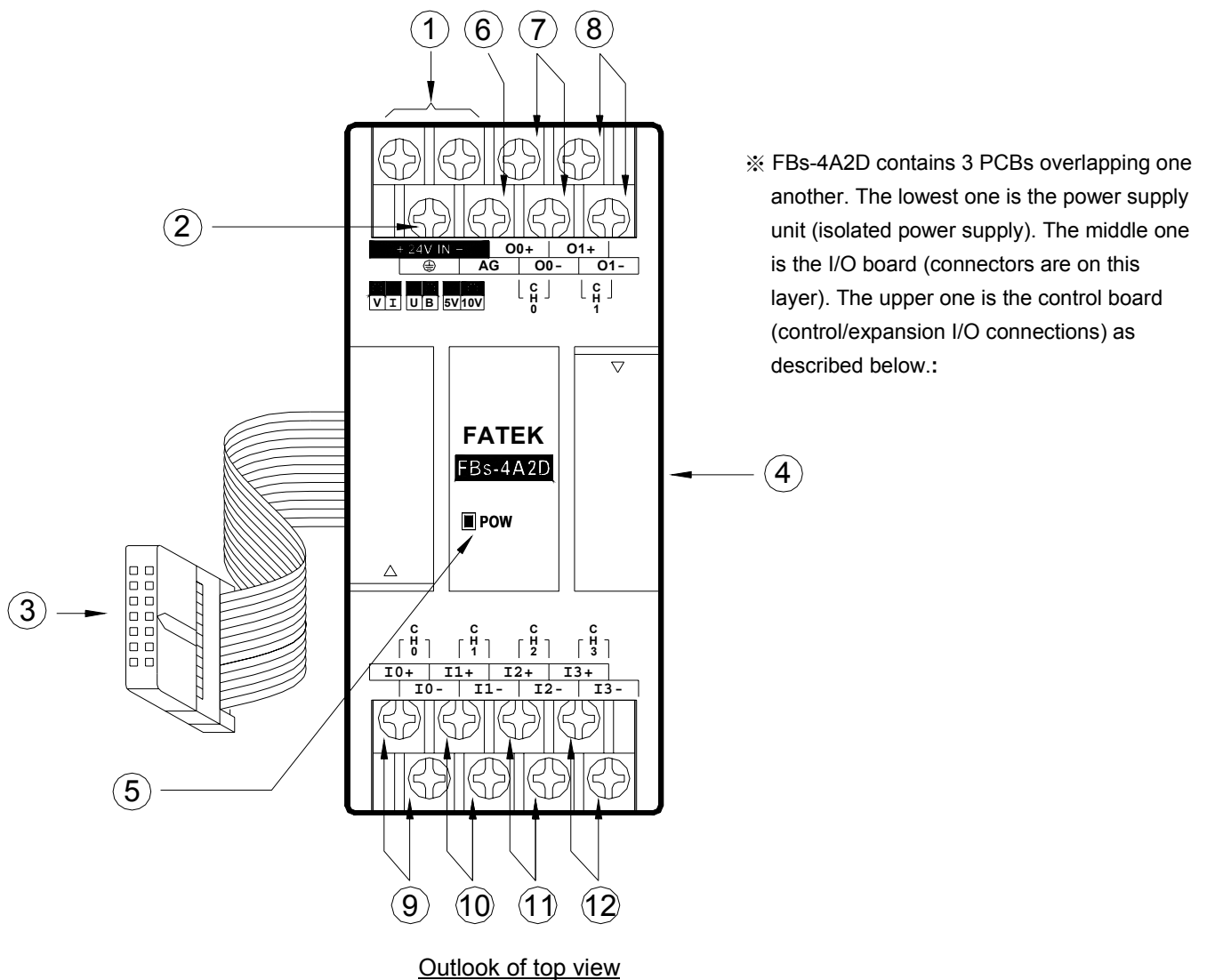

- ① External power input terminal : Power supply of analogue circuit for this module, the voltage can be $24VDC \pm 20\%$ and should be supplied with 4W of power at least.
- ② Protecting ground terminal : Connect to the shielding of signal cable.
- ③ Expansion input cable : It should be connected to the front expansion unit, or the expansion output of main unit.

- ④ Expansion output connector : Provides the connection for next expansion unit.
- ⑤ Power indicator : It indicates whether the power supply at analogue circuit and external input power source are normal.
- ⑥ AG Ground : No connection is needed in general; except when the common mode signal is too high. See examples overleaf for details.
- ⑦ 、 ⑧ : Output terminal of CH0~CH1.
- ⑨ 、 ⑫ : Input terminal of CH0~CH3.

20.4.1 FBs-4A2D hardware jumper setting

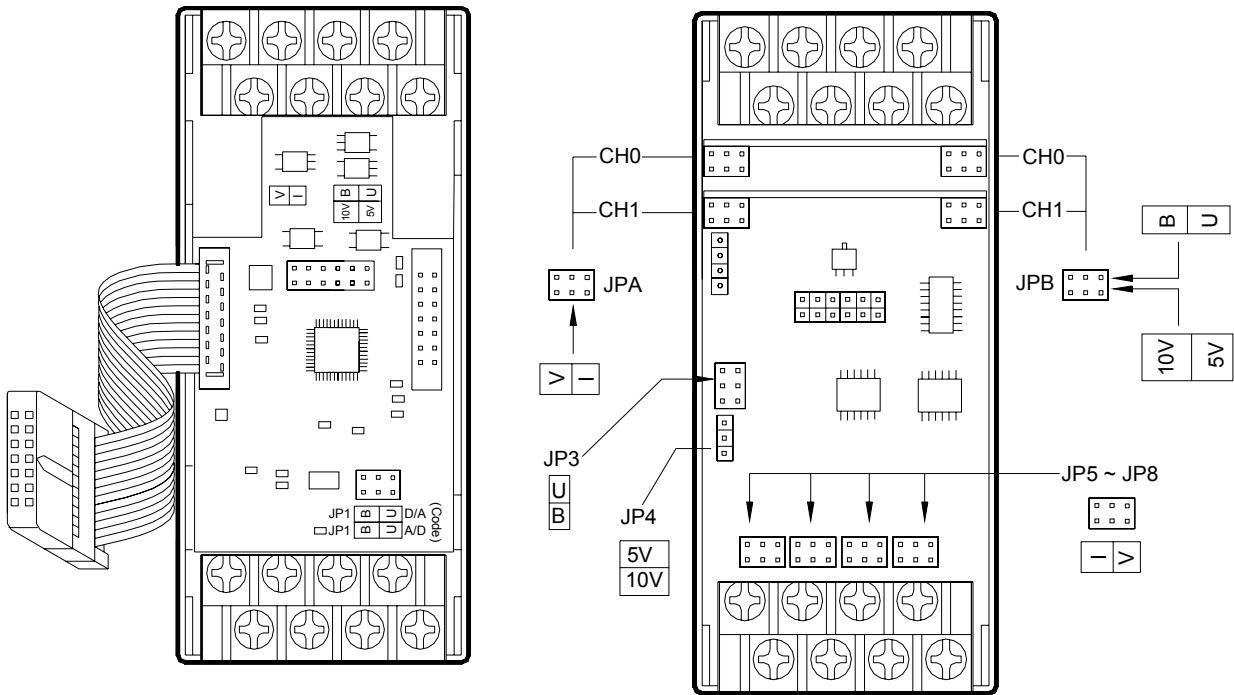



Pin Layout in Control Board (open top cover)

Pin Layout on I/O Board (Remove Control Board)

● (Analog output)

1. Output code format selection (JP1)

Users can select between unipolar and bipolar codes. The output range of unipolar codes and bipolar codes is 0~16383 and -8192~8191, respectively. The two extreme values of these formats correspond to the lowest and highest output signal values, respectively (see table below). In general, the output code format is selected according to the form of output signals; i.e. unipolar codes for unipolar output signals; and bipolar codes for bipolar output signals. In doing so, their correlations will become more heuristics. Yet, as the format of output code on all channels is selected from JP1, it is the user's choice to select unipolar or bipolar codes if both are used on different channels. See diagram above for location of JP1 :

Output Code Format	JP1 Setting	Output Value Range	Corresponding Input Signals
Bipolar	JP1  (D/A)	-8192 ~ 8191	-10V ~ 10V(-20mA ~ 20mA) -5V ~ 5V(-20mA ~ 20mA)
Unipolar	JP1  (D/A)	0 ~ 16383	0V ~ 10V(0mA ~ 20mA) 0V ~ 5V(0mA ~ 10mA)

2. Output signal form setup (JPA&JPB)

Users can set the output signal form (voltage/current) of individual channels; except the polarity and amplitude which are common.

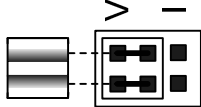
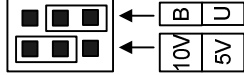
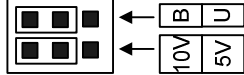
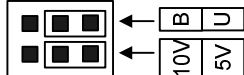
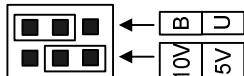
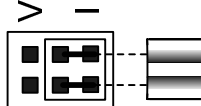
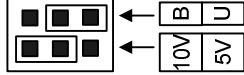
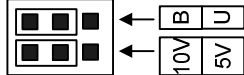
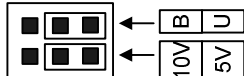
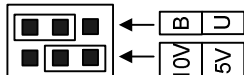

Signal Form	JPA (voltage/current) Setting	JPB (polarity/amplitude) Setting
0V ~ 10V		
-10V ~ 10V		
0V ~ 5V		
-5V ~ 5V		
0mA ~ 20mA		
-20mA ~ 20mA		
0mA ~ 10mA		
-10mA ~ 10mA		

● (Analog input)

1. Input code format selection (JP1)







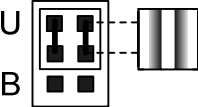
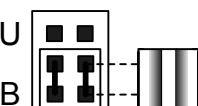

Users can select between unipolar and bipolar codes. The input range of unipolar codes and bipolar codes is 0~16383 and -8192~8191, respectively. The two extreme values of these formats correspond to the lowest and highest input signal values, respectively (see table below). For example, if the input signal type is set to -10V~ +10V, the unipolar code corresponding to the input is 8192 and the bipolar code corresponding to the input is 0 for 0V input. If the input is 10V, the unipolar code corresponding to the input is 16383 and the bipolar code corresponding to the input is 8191. In general, the input code format is selected according to the form of input signals; i.e. unipolar codes for unipolar input signals; and bipolar codes for bipolar input signals. In doing so, their correlations will become more heuristics. Unless it is

necessary to make a deviation conversion through FUN32; otherwise, do not select bipolar codes for unipolar input signals (see FUN32 description for details). The format of input codes of all channels is selected from JP1. See above diagram for the location of JP1 :

Input Code Format	JP1 Setting	Input Value Range	Corresponding Input Signals
Bipolar	JP1  (A/D)	-8192 ~ 8191	-10V ~ 10V (-20mA ~ 20mA) -5V ~ 5V (-20mA ~ 20mA)
Unipolar	JP1  (A/D)	0 ~ 16383	0V ~ 10V (0mA ~ 20mA) 0V ~ 5V (0mA ~ 10mA)

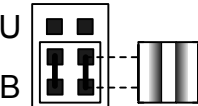
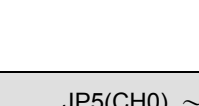
2. Input signal form setup (JP3&JP4)

Users can set the input signal form (voltage/current) of individual channels; except the polarity and amplitude which are common. The location of jumpers are tabulated below :

Signal Form	JP3 Setting	JP4 Setting
0 ~ 10V or 0 ~ 20mA	U  B 	 5V  10V
0 ~ 5V or 0 ~ 10mA		 5V  10V
-10 ~ +10V or -20 ~ +20mA	U  B 	 5V  10V
-5 ~ +5V or -10mA ~ +10mA		 5V  10V

3. Voltage or current setting (JP5~JP8)

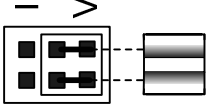
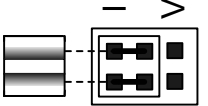
Signal Type	JP5(CH0) ~ JP8(CH3) Setting
Voltage	
Current	

20.5 FBs-4A2D input/output circuit diagram

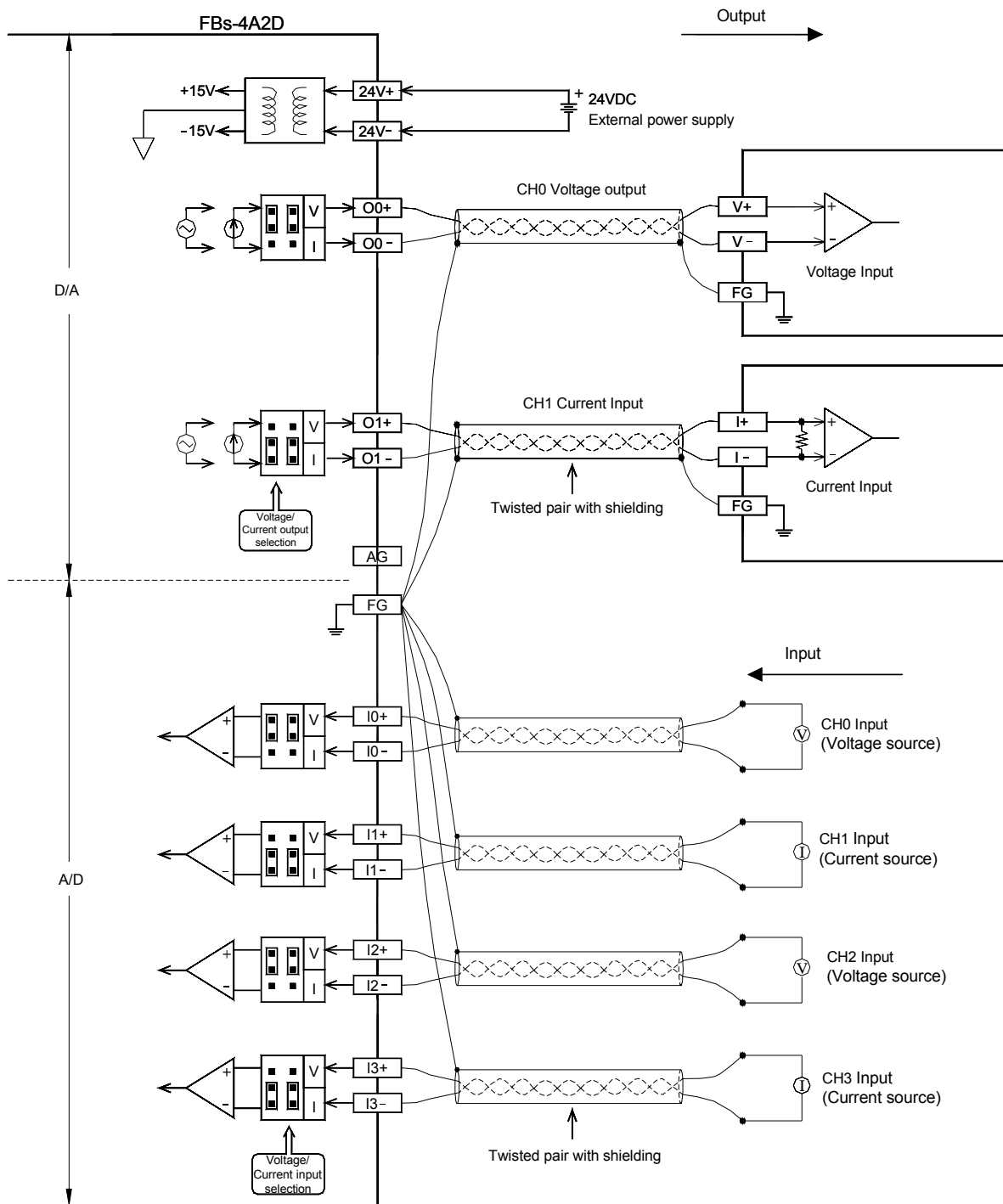

20.6 FBs-4A2D input/output characteristics

Users can select the I/O ranges of FBs-4A2D from the jumpers described above, such as V/I, U/B (I/O codes), U/B (signal form), 5V/10V, etc. The I/O conversion characteristics of these settings are illustrated below. Users can adjust different I/O forms by coordinating the conversion curve with various V/I (voltage/current) I/O settings. See Section 20.4 for details of V/I settings.

Diagram 1 : Bipolar 10V (20mA) Span

Input/Output Range	Voltage	-10V ~ 10V
	Current	-20mA ~ 20mA

14 bit input/output format

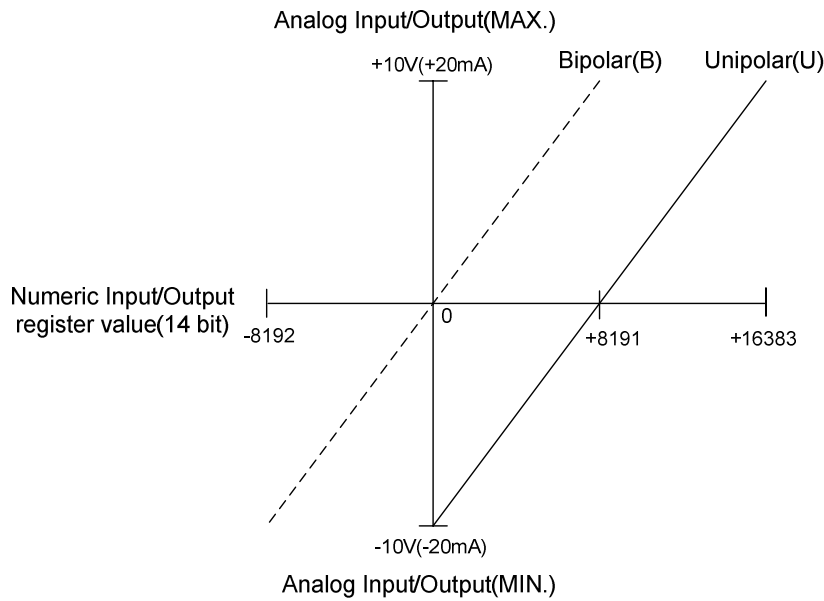

12 bit input format

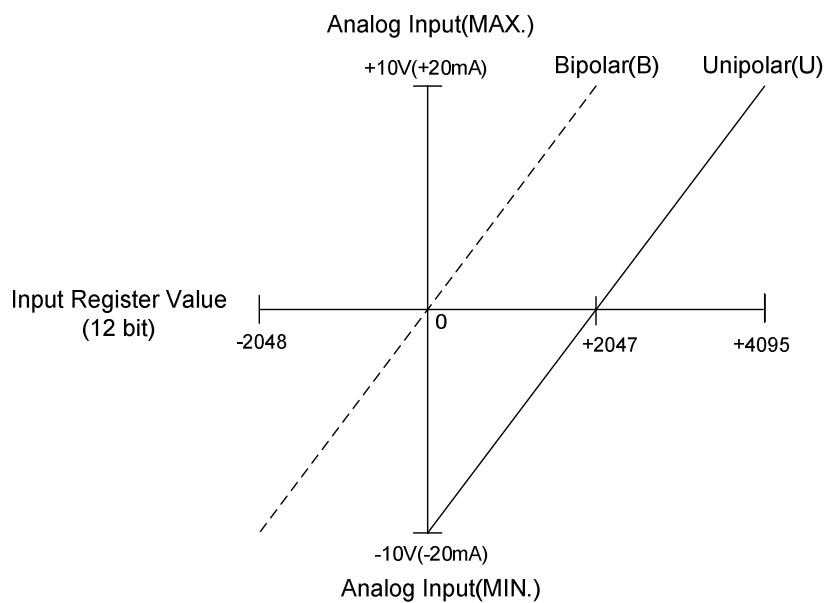

※ No 12-bit mode for analog output

Diagram 2 : Bipolar 5V (10mA) Span

Input/Output Range	Voltage	-5V ~ 5V
	Current	-10mA ~ 10mA

14 bit input/output format

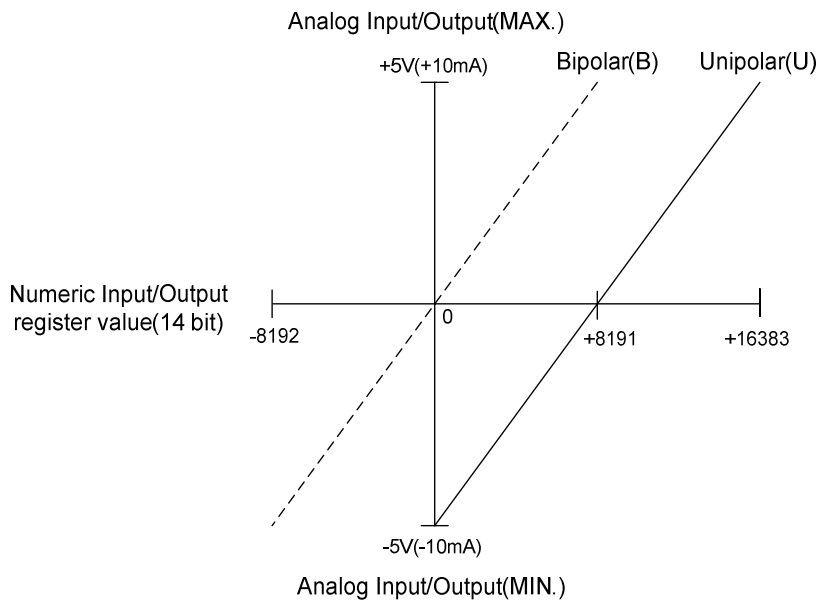

12 bit input format

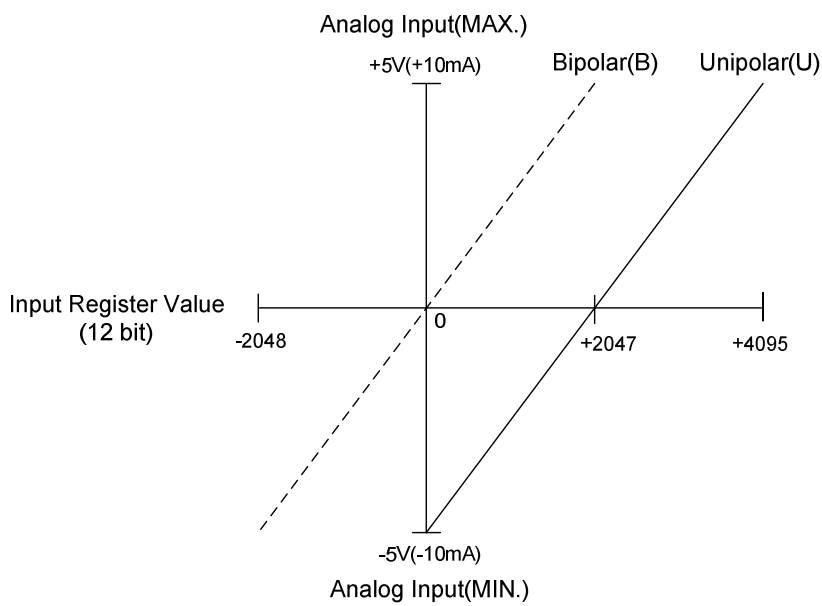

※ No 12-bit mode for analog output

Diagram 3 : Unipolar 10V (20mA) Span

Input/Output Range	Voltage	0V ~ 10V
	Current	0mA ~ 20mA

14 bit input/output format

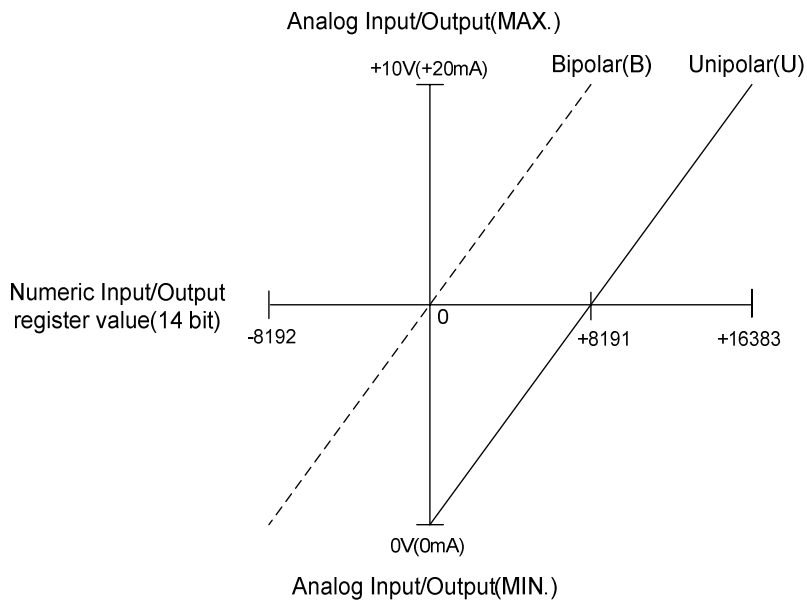

12 bit input format

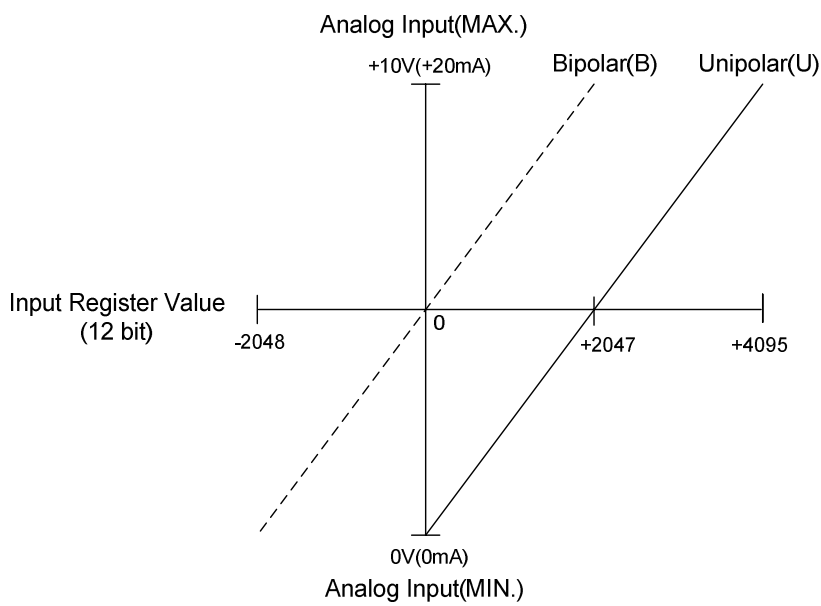

※ No 12-bit mode for analog output

Diagram 4 : Unipolar 5V (10mA) Span

Input/Output Range	Voltage	0V ~ 5V
	Current	0mA ~ 10mA

14 bit input/output format

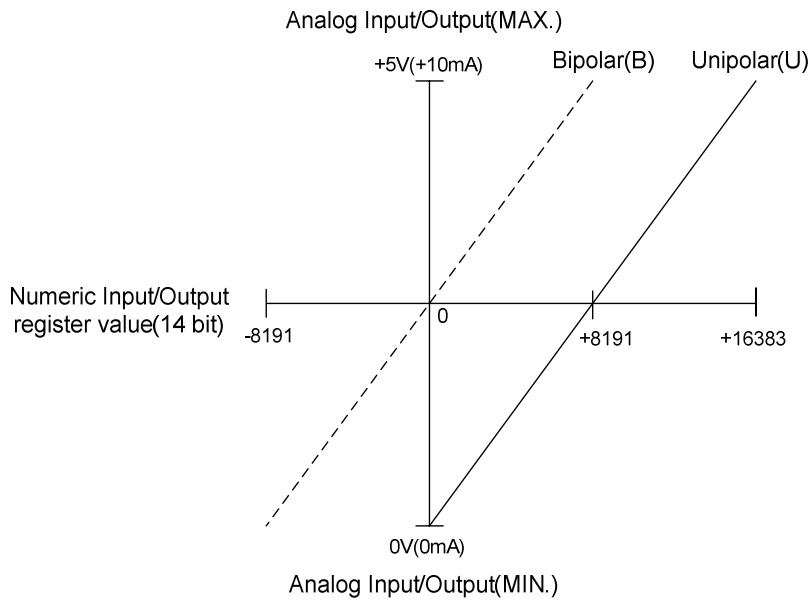

12 bit input format

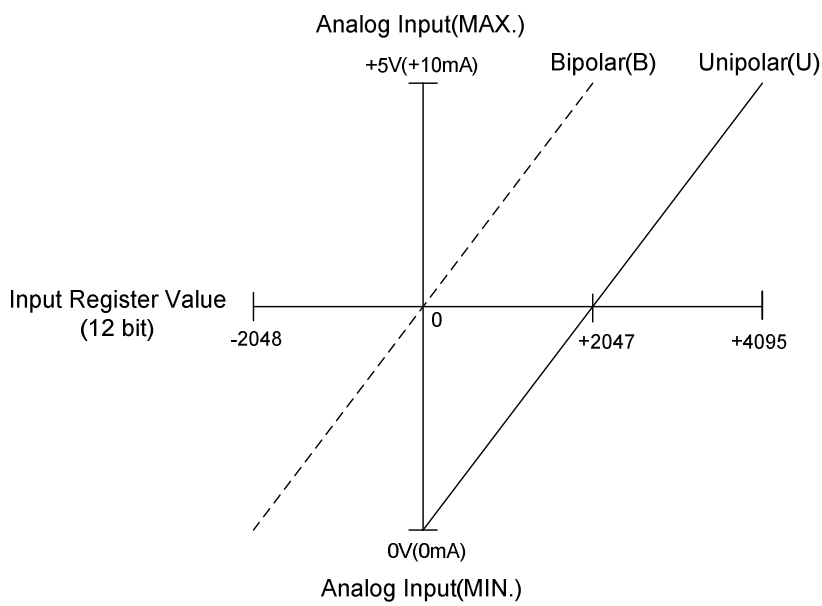

※ No 12-bit mode for analog output

20.7 FBs-4A2D analog input format planning

The reading input format planning of FBs-4A2D is exactly the same as that of FBs-6AD. See Section 18.7 for details. The figure below shows the FBs-4A2D analog input format planning screen in WinProLadder.

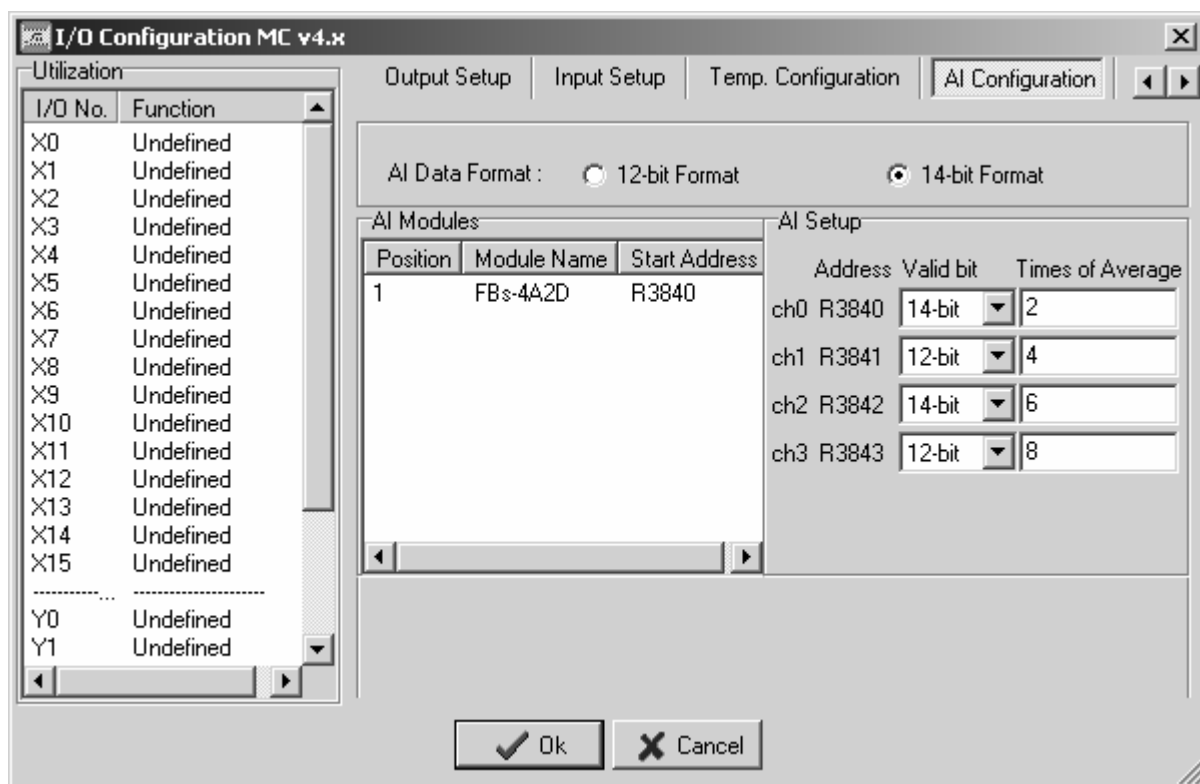



MEMO

