

Appendix 3 FBs-PACK Operation Instruction

The main unit of FBs series PLC provides the function to write ladder program and the selected data registers into MEMORY_PACK directly.

FBs-PACK is the product name of MEMORY PACK; the memory capacity is 64K WORD. Setting the DIP switch of the MEMORY_PACK at the unprotect position while writing, and at the protect ON position to avoid accidental writing.

To operate friendly, WinProladder supports the corresponding MEMORY PACK operation interface; but for general usage, the direct register's access method is also introduced for further reference.

1.1 Write program and register data to FBs-PACK through WinProladder

Select Run MEMORY_PACK from Tool : Tool
└─ MEMORY_PACK operations :

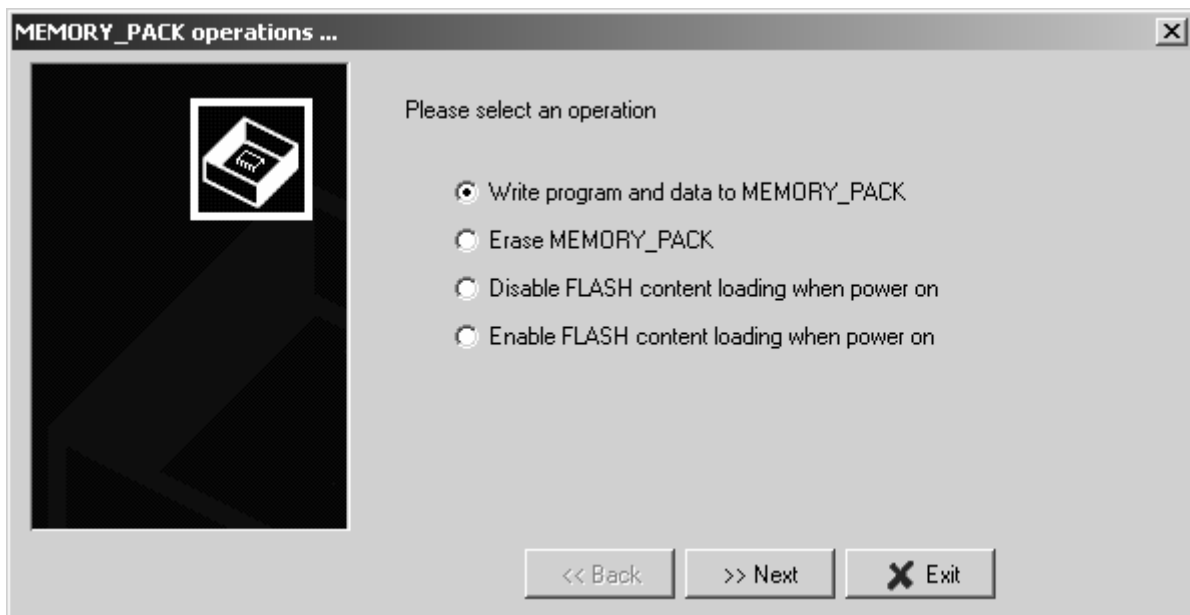

- Write program and data to MEMORY_PACK :

Users can write programs and data into the MEMORY_PACK with this function. After clicking Next, the window display below :

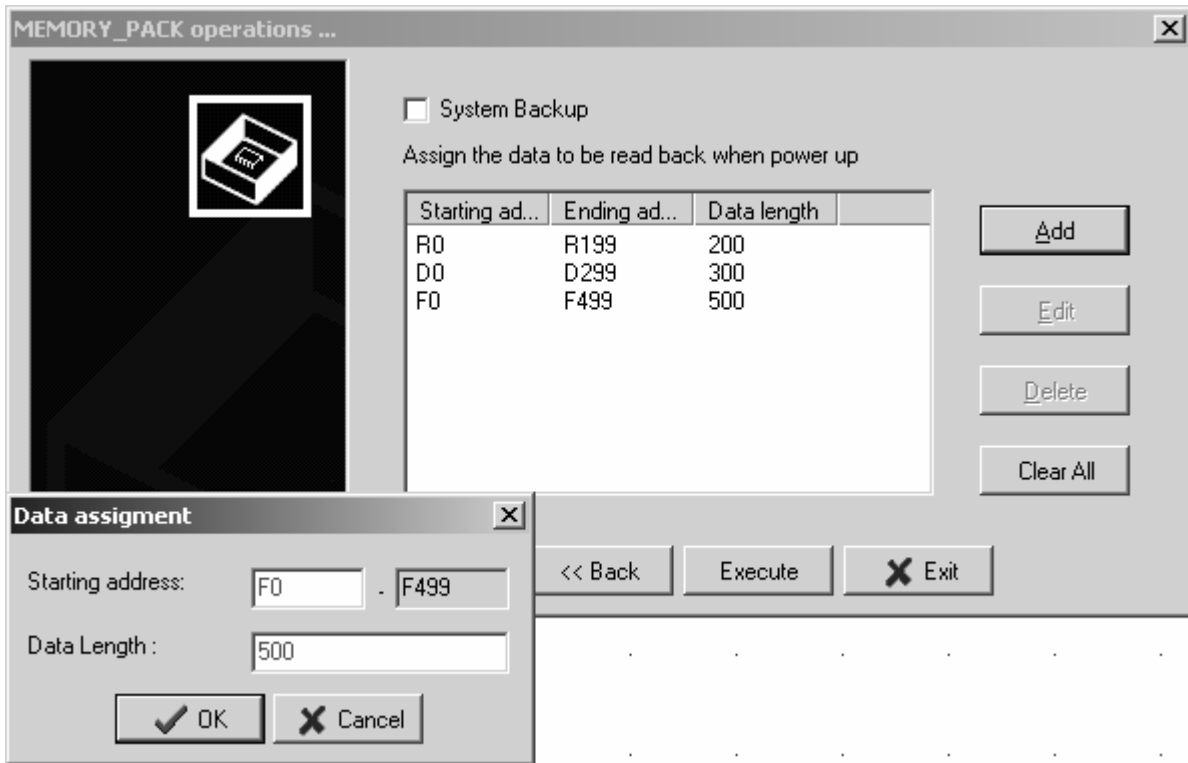

Users can assign the range of registers which you want to read from MEMORY_PACK and write into PLC. If you don't want to back-up any data of register, press "Execute" to start. The execution time may differ depending on the size of ladder program and register data. During writing data into MEMORY_PACK, the system will appear the message "Under programming, please wait...". If the data are successfully stored into MEMORY_PACK, the message "MEMORY_PACK write OK" will appear. If it failed, the message "MEMORY_PACK write error" will appear.

- ※ It is allowed up to 4 groups of register or system backup for MEMORY_PACK manipulation, click "Add" or "Edit" or "Delete" to accomplish the writing and further retrieve of the selected registers.
- ※ The item "System Backup" means stored all of data (including the PLCID and station number of PLC) into MEMORY_PACK.

- Erase MEMORY_PACK :

Users can clear programs or data stored in MEMORY_PACK with this function. click "Next", it is showing "Under erase, please wait...". It will show "MEMORY_PACK erase OK" if this erase is successful. It will show "MEMORY_PACK erase error" if this erase is failed.

- Disable FLASH content loading when power on :

Users can enter the test run modification mode with this function. Press Next to enter test run modification mode (Disable programs and data overwrite).

- ※ If the user needs to equip with a new MEMORY_PACK, selecting this item first to avoid the undesired overwrite of ladder program by which storing in the new MEMORY_PACK while power up. This function is used to let the main unit enter into the "Modify and Testing" mode for programming if it equips with the MEMORY_PACK. Please refer to the next page for detailed description.

- Enable FLASH content loading when power on :

Press Next to complete normal mode setup.

- ※ Every power up, the ladder program and the selected data registers storing in battery backup RAM of the main unit will be replaced by which storing in the MEMORY_PACK (if this MEMORY_PACK was equipped with the main unit and it had ever been written the ladder program), and the PLC will enter into "RUN" mode automatically regardless it's "RUN" or "STOP" mode before.
- ※ For mass production of machine manufacturing or for long term easy after sale maintenance, the MEMORY_PACK is a very good solution.

1.2 Write program and register data to FBs-PACK through special register operation

To meet the application needs of different customers, users can write data into MEMORY_PACK by setting special register. WinProladder users can skip this section because setting actions will be completed at the same time when executing MEMORY_PACK options with WinProladder.

Operation relevant special register

- R4052 : Dedicated register for MEMORY_PACK operation.

Register	Content value	Functions
R4052	5530H (Test run modification mode)	<p>Modify & Test mode for PLC programming while main unit being equipped with the MEMORY_PACK.</p> <p>There are 2 kinds of memory on main unit to store the ladder program and data registers; one is the battery backup RAM, this is standard equipment and the ladder program and data registers must be executed here; another memory to store the ladder program and data registers is the optional MEMORY_PACK, the ladder program and data registers can't be executed here directly. In Modify & Test mode, the ladder program and data registers storing in battery backup RAM of main unit will not be overwritten by the MEMORY_PACK's while power up; it means the content of the battery backup RAM will be kept, and the modification if ever will not be lost, this is so called "Modify & Test mode".</p> <p>After the modification and testing has been finished, writing the ladder program and data registers into the MEMORY_PACK is a better way for long term saving and easy after sale service of maintenance or for mass copy of same machine's program.</p> <p>During the modification and testing, if the user want to give up the change, it is only to set R4052 to be 0, and turn off then turn on the power again, the ladder program and data registers storing in battery backup RAM will be overwritten by which storing in the MEMORY_PACK while power up, the main unit will return to the environment before modification.</p>

R4052	Other value	Normal operation or Writing mode. If the main unit equips with the optional MEMORY_PACK, and the MEMORY_PACK had ever been written the ladder program before, while every power up, the ladder program storing in battery backup RAM of the main unit will be replaced by which storing in the MEMORY_PACK, and the PLC will enter into "RUN" mode automatically regardless it's "RUN" or "STOP" mode before.
-------	-------------	--

- R4046 : Dedicated register to retrieve the data registers storing in ROM_PACK.

While writing the ladder program into the MEMORY_PACK along with the selected data registers, the content of the selected data registers (locating at the RAM of the main unit) will be initialized with the values which previously being written into the MEMORY_PACK on each power up; it is very useful for machine turning parameter's long term saving and after sale service of maintenance.

But in many applications, it needs only one time initialization for the selected data registers while the first power up and then the contents of those will be retentive after followings' power up.

User may control the value of R4046 to accomplish above mentioned applications.

Register	Content value	Functions
R4046	5530H	The selected data registers of the main unit will not be initialized with the values which previously being written into the MEMORY_PACK while power up.
	Other value	The selected data registers of the main unit will be initialized with the values which previously being written into the MEMORY_PACK while power up.

※ If it needs only one time initialization for selected data registers while the first power up, fill the register R4046 with the value 5530H in the ladder program.

- Either PLC in RUN or in STOP mode, the user can give the command to clear MEMORY_PACK or write the ladder program and selected registers into MEMORY_PACK.

Register	Content value	Functions
R4052	5550H	giving the command to clear MEMORY_PACK
	5551H	the status to say " Being cleared"
	5552H	the status to say "Verify for clearing"
	5553H	the status to say "Complete the clear command "
	5554H	the status to say "Failed to clear the MEMORY_PACK"
	5560H	giving the command to write ladder program and selectde registers into MEMORY_PACK
	5562H	the status to say "Writing the Ladder Program"
	5563H	the status to say "Writing the Registers"
	5566H	the status to say "Verify the Ladder Program"
	5567H	the status to say "Verify the Registers"
	5569H	the status to say "Verify the Special Register"
	556AH	the status to say "Complete the writing"
	556BH	the status to say "Failed to write ladder program"
	556CH	the status to say "Failed to write registers"

1.3 Assigning the retrieval of register stored FBs-PACK

- The contents of the selected registers can be written into the MEMORY_PACK and those will be read back from the MEMORY_PACK for initialization while every power up. The tuning values or fixed preset values can be written into the MEMORY_PACK for this kind of application to keep proper operation even the loss of the battery power.
- The special registers of R4030~R4039 are used to assign which group of registers needed to be written into MEMORY_PACK for above mentioned application, it is necessary to do the assignment first before giving command to write the MEMORY_PACK.

Register	Content value	Functions
R4030	A66AH	It is the identification flag to tell the selected registers needed be written into and read back from the MEMORY_PACK according to the following settings of R4031~R4039 (Retentive registers support this function).
	Other value	There is not any register needed be written into and read back from the MEMORY_PACK.
R4031	1~4	Quantity of register groups needed be written into and read back from the MEMORY_PACK (4 in maximum).
R4032	Length 0	The data length of register group 0. The length is between 1 ~ 3840 for register R0 ~ R3839; The length is between 1 ~ 3072 for register R5000 ~ R8071; The length is between 1 ~ 4096 for register D0 ~ D4095; The length is between 1 ~ 166 for register R4000 ~ R4165; While the length is 7FF7H, it means for system backup including the PLCID and station number of PLC ; It will not work when illegal length or out of range;
R4033	Start 0	The starting address of register group 0. The address is between 0 ~ 3839 for register R0 ~ R3839; The address is between 5000 ~ 8071 for R5000 ~ R8071; The address is between 10000 ~ 14095 for D0 ~ D4095; (The address must be added by 10000 for register Dxxxx) The address is between 4000 ~ 4165 for R4000 ~ R4165; R4033 and R4032 are used in pair.
R4034	Length 1	The data length of register group 1. The ranges of length same as mentioned above for R4032;
R4035	Start 1	The starting address of of register group 1. The ranges of address same as mentioned above for R4033; R4035 and R4034 are used in pair.
R4036	Length 2	The data length of register group 2 The ranges of length same as mentioned above for R4032;
R4037	Start 2	the starting address of of register group 2 The ranges of address same as mentioned above for R4033; R4037 and R4036 are used in pair.

Register	Content value	Functions
R4038	Length 3	The data length of register group 3 The ranges of length same as mentioned above for R4032;
R4039	Start 3	the starting address of of register group 3 The ranges of address same as mentioned above for R4033; R4039 and R4038 are used in pair.

1.4 Read and write FBs-PACK by function instruction

You also can read and write data or ladder program by Function Instruction(FUN161 · FUN162). The followings are the instructions explanation and program example for FUN161 and FUN162 :

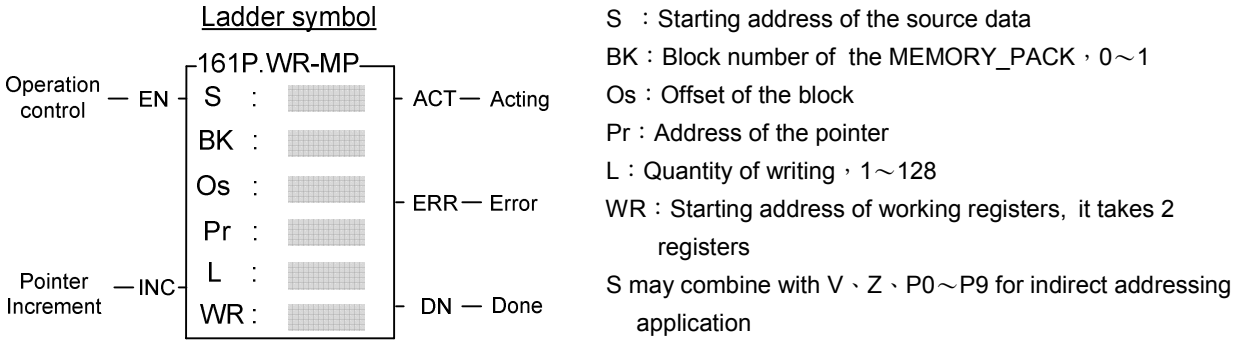

Operand	Range	HR	ROR	DR	K	XR
		R0 R3839	R5000 R8071	D0 D4095		V、Z P0~P9
S		○	○	○		○
BK					0~1	
Os		○	○	○	0~32510	
Pr		○	○*	○		
L		○	○*	○	1~128	
WR		○	○*	○		

● The main purpose of the MEMORY_PACK of FBs series's is used for long term storing of the user's ladder program, except this, through the FUN161/FUN162 instructions, the MEMORY_PACK can be worked as the portable MEMORY_PACK for machine working parameters's saving and loading.

When execution control "EN" changes from 0→1, it will perform the data writing, where S is the starting address of the source data, BK is the block number of the MEMORY_PACK to store this writing, Os is the offset of specified block, Pr is the pointer to point to corresponding data area, L is the quantity of this writing. The access of MEMORY_PACK manipulation adopts the concept of RECORD data structure to implement with. The working diagram as shown below :

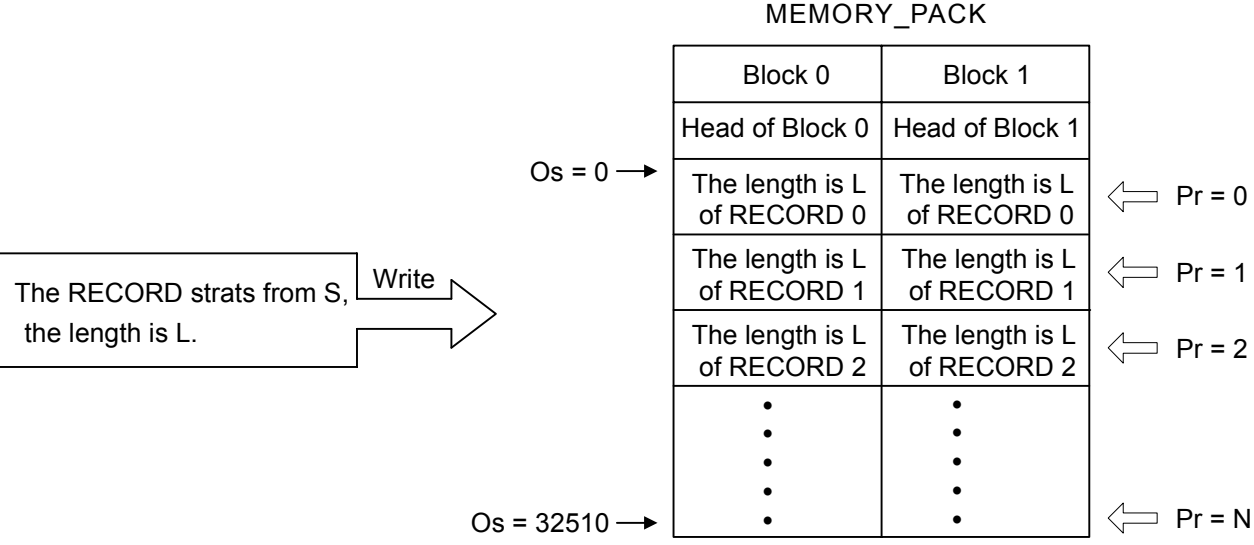

● When input "INC" = 1, the content of the pointer will be increased by one after the execution of writing, it points to next record.

FUN161P
WR-MP

Write Data Record into the MEMORY_PACK
(Write memory pack)

FUN161P
WR-MP

- If the value of L is equal to 0 or greater than 128, or the pointed data area over the range, the output "ERR" will be 1, it will not perform the writing operation.
 - It needs couple of PLC solving scans for data writing and verification; during the execution, the output "ACT" will be 1; when completing the execution and verification without the error, the output "DN" will be 1; when completing the execution and verification with the error, the output "ERR" will be 1.
- The MEMORY_PACK can be configured to store the user's ladder program or machine's working parameters, or both. The ladder program can be stored into the block 0 only, but the machine's working parameters can be stored into block 0 or 1; the memory capacity of each block has 32K Word in total.

Example program : Writing the record into block 1 of MEMORY_PACK with the different length

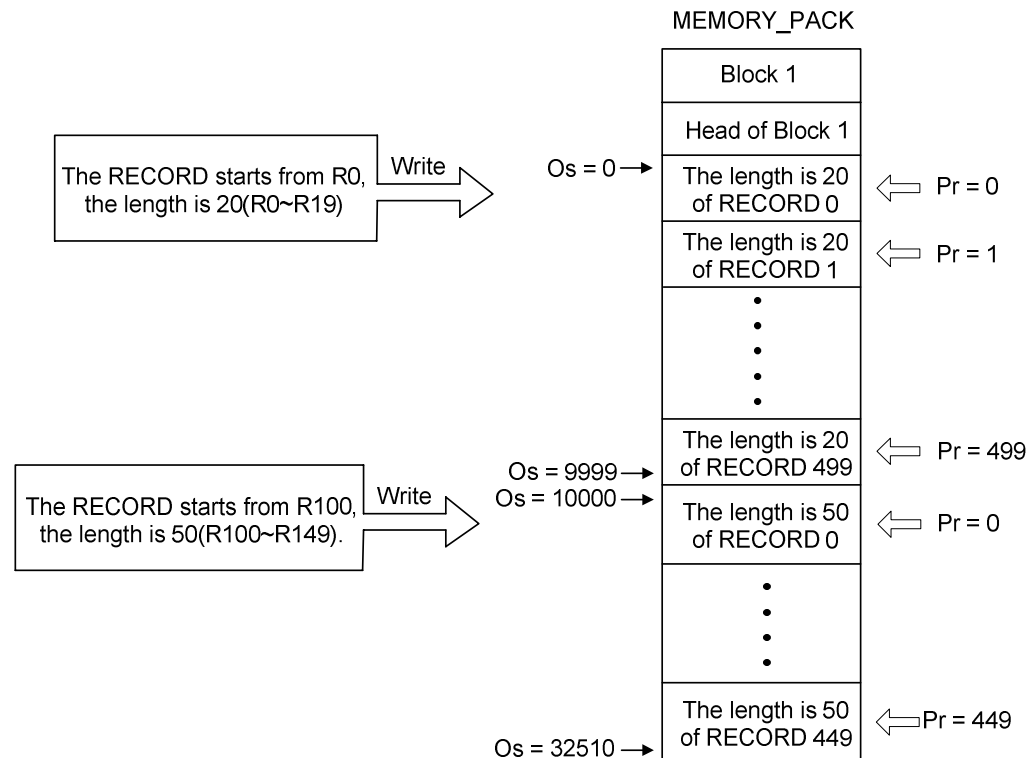
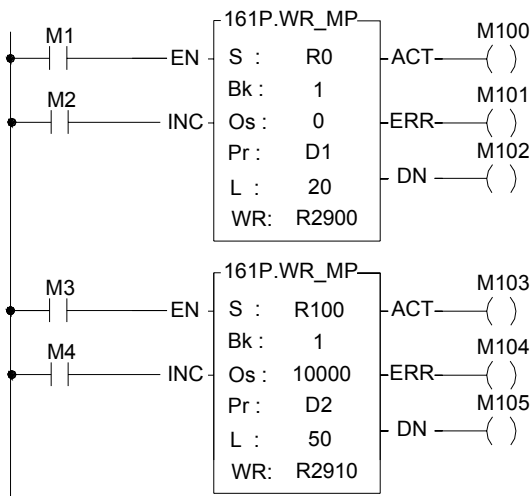

FUN162 P RD-MP	Read Data Record from the MEMORY_PACK (Read memory pack)	FUN162 P RD-MP
--------------------------	---	--------------------------

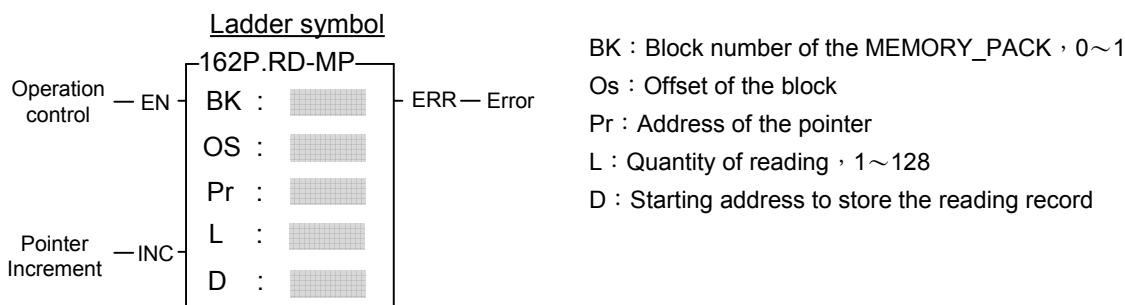

Operand	Range	HR	ROR	DR	K
			R0 R3839	R5000 R8071	D0 D3999
BK					0~1
Os		○	○	○	0~32510
Pr		○	○*	○	
L		○	○*	○	1~128
D		○	○*	○	

- If the MEMORY_PACK of the FBs series's has stored the data record written by the FUN161 instruction, they can be read out for machine's working through this instruction, it will reduce the tuning time for machine operation.
- When execution control "EN" = 1 or from 0→1(**P** instruction), it will perform the data reading, where BK is the block number of the MEMORY_PACK storing the record, Os is the offset of specified block, Pr is the pointer to point to corresponding data area, L is the quantity of this record, and D is the starting address to stor this reading of record. The access of MEMORY_PACK manipulation adopts the concept of RECORD data structure to implement with.
 The working diagram as shown below:

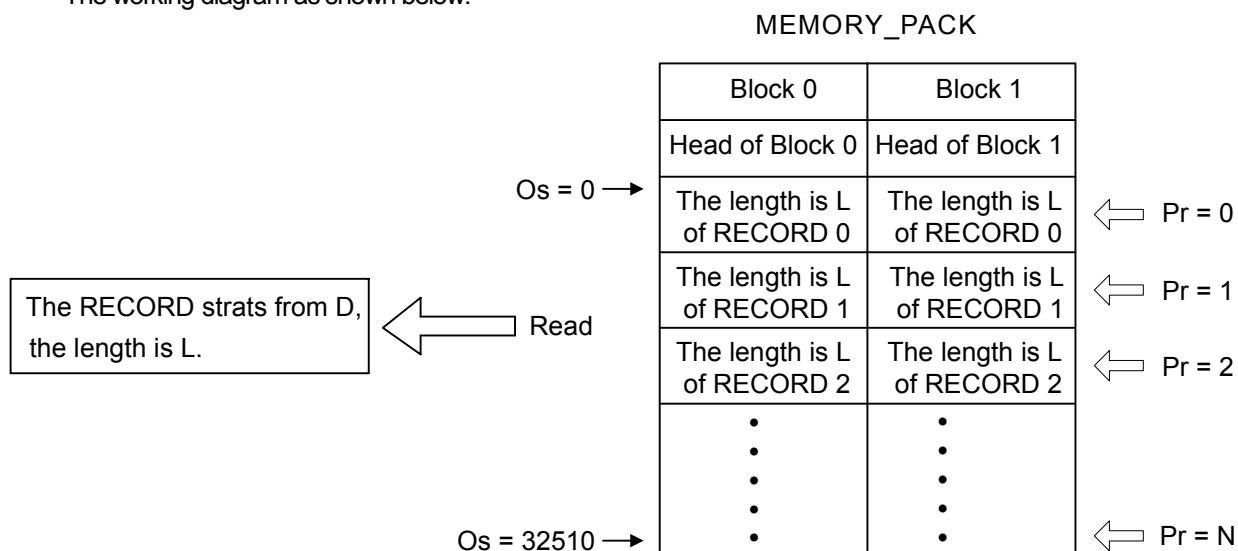

- When input "INC"=1, the content of the pointer will be increased by one after the execution of reading, it points to next record.

Advanced Function Instruction

FUN162 P RD-MP	Read Data Record from the MEMORY_PACK (Read memory pack)	FUN162 P RD-MP
--------------------------	---	--------------------------

- If the value of L is equal to 0 or greater than 128, or the pointed data area over the range, the output "ERR" will be 1, it will not perform the reading operation.
- Output will be "ERR" if MEMORY_PACK is empty or data format not correct, and user used FUN162 to read data from MEMORY_PACK.

Example program : Reading the record from block 1 of MEMORY_PACK with the different length

※ It is necessary that correct data in MEMORY_PACK or this example can't execute correctly.

